

International Journal of Innovative Research in Science, Engineering and Technology

(A High Impact Factor, Monthly, Peer Reviewed Journal)

Visit: www.ijirset.com

Vol. 7, Issue 11, November 2018

Design and Implementation of Cycloconverter

Nawale Tejashree L¹, Thorat Pranali R²

Assistant Professor, Department of E&TC, RGCOE, Ahmednagar, India¹

Lecturer, Department of E&TC, RGCOE, Ahmednagar, India²

ABSTRACT: The project is designed to control the speed of an induction motor in three steps by using cycloconverter technique. In manufacturing and process industries, the variable frequency is required for driving various electrical machineries. The cycloconverter or variable frequency generator plays a significant role in driving those electrical machineries. The study mainly focuses on the design and construction of the single phase cycloconverter. As the AC supply frequency cannot be changed, so this project uses a PICcontrolled cycloconverter which enables the control of speed in steps for an induction motor. Microcontroller is used in this project, a pair of slide switches is provided to select the desired speed range (F, F/2 and F/4) of operation of the induction motor. These switches are interfaced to the microcontroller. The status of the switches enables the microcontroller to deliver the pulses to trigger the SCR's in a dual bridge. Thus, the speed of the an induction motor can be achieved in three steps i.e. (F, F/2 and F/4). This very concept can be further enhanced and implemented to control the speed of a three phase induction motor as well. It can also be coupled with firing angle control for any desired speed.

KEYWORDS: Voltage Regulator, Zero Crossing detector, cycloconverter.

I. INTRODUCTION

Cycloconverter are used in high power applications driving induction and synchronous motors. They are usually phase-controlled and they traditionally use thyristor due to their ease of phase commutation. Power conversion systems such as those used for large propulsion motor drives will often utilize cycloconverter technology in order to take advantage of the power handling capability of modern thyristor. Because cycloconverter produce non-integer harmonics of the input power frequency, both input current and output voltage require detailed study in order to insure trouble-free operation of both the supplying power system and the connected motor load.

The cycloconverter is a device which converts input AC power at one frequency to output AC power at a different frequency with a one stage conversion. The frequency conversion is achieved using a phase control method. Phase controlled cycloconverter have the ability to operate in all 4 quadrants in the V-I plane. Thus, cycloconverter are capable of providing a variable frequency power supply to AC machines. Due to its 4-quadrant operation, the cycloconverter can handle loads of any power factor. The cycloconverter also allows power to flow freely in either direction. Over most of its range, the cycloconverter produces a reasonable sine wave output that leads to good output performance, particularly at lower frequencies. Traditionally, satisfactory performance has been understood to be available when the output frequency is up to approximately 40 percent of the input frequency.

International Journal of Innovative Research in Science, Engineering and Technology

(A High Impact Factor, Monthly, Peer Reviewed Journal)

Visit: www.ijirset.com

Vol. 7, Issue 11, November 2018

II. BLOCK DIAGRAM

Following figure1 shows the block diagram of cycloconverter in which it consist of :

1. Microcontroller
2. Transformer
3. Voltage Regulator
4. Bridge Rectifier
5. Motor

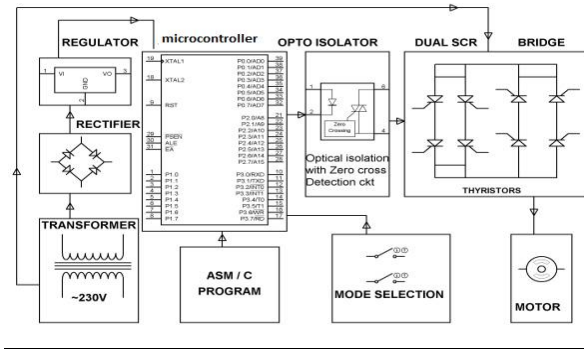

Fig. 1 Block diagram of cycloconverter

VOLTAGE REGULATOR

The LM78XX/LM78XXA series of three-terminal positive regulators are available in the TO- 220/D-PAK package and with several fixed output voltages, making them useful in a Wide range of applications. Each type employs internal current limiting, thermal shutdown and safe operating area protection, making it essentially indestructible. If adequate heat sinking is provided, they can deliver over 1A output Current. Although designed primarily as fixed voltage regulators, these devices can be used with external components to obtain adjustable voltages and currents.

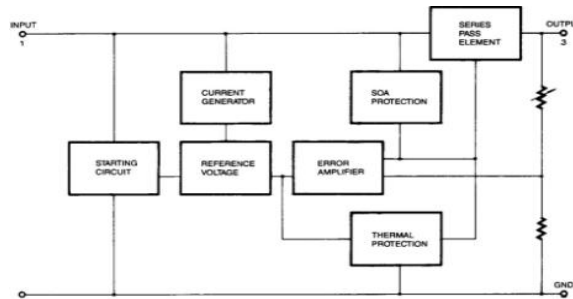

Fig 2. Block diagram of voltage regulator.

Parameter	Symbol	Value	Unit
Input Voltage (for $V_O = 5V$ to $18V$)	V_I	35	V
(for $V_O = 24V$)	V_I	40	V
Thermal Resistance Junction-Cases (TO-220)	$R_{\theta JC}$	5	$^{\circ}C/W$
Thermal Resistance Junction-Air (TO-220)	$R_{\theta JA}$	65	$^{\circ}C/W$
Operating Temperature Range (KA78XX/A/R)	T_{OPR}	0 ~ +125	$^{\circ}C$
Storage Temperature Range	T_{STG}	-65 ~ +150	$^{\circ}C$

Fig 2a. Absolute maximum rating.

International Journal of Innovative Research in Science, Engineering and Technology

(A High Impact Factor, Monthly, Peer Reviewed Journal)

Visit: www.ijirset.com

Vol. 7, Issue 11, November 2018

It has some features:

- Output Current 1A.
- Output Voltages 5V.
- Thermal Overload Protection.
- Short Circuit Protection.
- Output Transistor Safe Operating Area Protection.

ZEROCROSSING DETECTION

Figure 3 shows the circuit diagram for zero crossing detector in which operational amplifier is used to detect zero crossing .

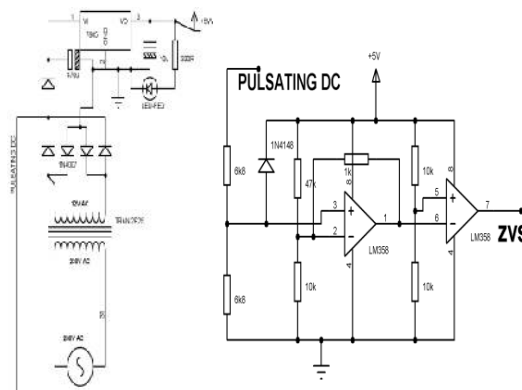

Fig 3. Circuit diagram of zero crossing detection

III. WORKING

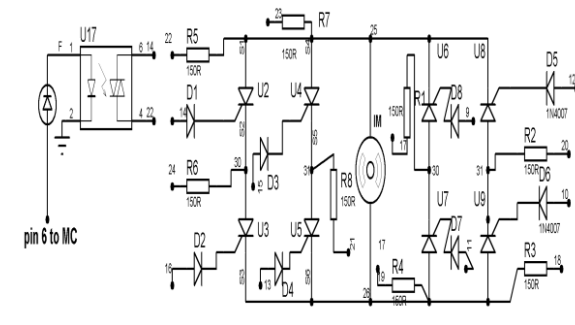

Fig 4. Thyristor switching by zvs

The project uses zero voltage reference as described 1. Eight Optoisolator i.e., MOC3023 are used for driving 8 SCR's U2 to U9. 4 SCR's used in full bridge are in anti-parallel with another set of 4 SCR's as shown in the diagram. Triggering pulses so generated by the microcontroller as per the program written provides input condition to the Optoisolator that drive the respective SCR. SCR gets conducting for 20ms from 1st bridge and next 20ms from the 2nd bridge to get the output and total time period of one AC cycle of 40ms which is 25 Hz. Thus F/2 is delivered to the load while switch 1 is closed and switch 2 is operated.

Similarly for F/4 the conduction takes place for 30ms in the 1st bridge and next 30ms from the next bridge, such that a total time period of 1 cycle comes to 60ms which in turn in F/4 while switch 3 is operated. Fundamental

International Journal of Innovative Research in Science, Engineering and Technology

(A High Impact Factor, Monthly, Peer Reviewed Journal)

Visit: www.ijirset.com

Vol. 7, Issue 11, November 2018

frequency of 50Hz is available by triggering on pair from the 1st bridge for 1st 10ms and for the next 10ms from the next bridge while both the switches are kept in “OFF” condition. Reverse current flowing in the gates of the SCR’s are Optoisolator output. bridge rectifier . The rectifier converts 12V ac to 12VDC . output of the rectifier is fed to the Voltage regulator 7805 it gives the output of 5V DC.

The 5V DC is given to VCC of the pic18F452. The micro controller has been programmed i.e. ASM/C program to give output to optical isolation with zero cross detection circuit. It compares two signals in order to get zero crossing whenever the zero crossing occurs it gives an output. A microcontroller programme is developed to control the firing pulses of gate driving circuit, these firing pulses are controlled by DIACs. The output of the cycloconverter is fed to the induction motor to control the speed at different frequencies.

MULTISIM DESIGN OF POWER SUPPLY

Figure 5. shows the multisim design of power supply.

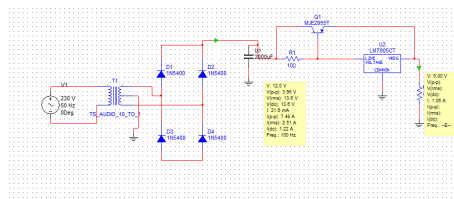

Fig 5. Multisim Design of power supply.

CIRCUIT DIAGRAM AND DESCRIPTION

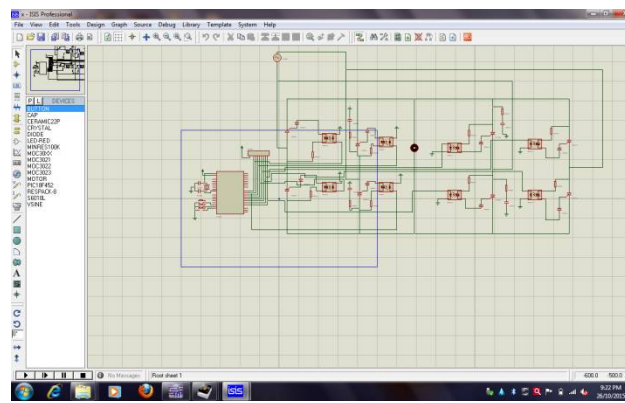

Fig 6. Proteus design of cycloconverter circuit.

Single phase 230 V Power supply is given the transformer for step down the voltage from 230v AC to 12V AC. The 12v AC is then fed to the bridge rectifier . The rectifier converts 12V ac to 12V DC output of the rectifier is fed to the Voltage regulator 7805 it gives the output of 5V DC.

The 5V DC is given to VCC of the pic 18F452. The micro controller has been programmed i.e. ASM/C program to give output to optical isolation with zero cross detection circuit. It compares two signals in order to get zero crossing whenever the zero crossing occurs it gives an output. . A microcontroller programme is developed to control the firing pulses of gate driving circuit, these firing pulses are controlled by DIACs. The output of the cycloconverter is fed to the induction motor to control the speed at different frequencies.

International Journal of Innovative Research in Science, Engineering and Technology

(A High Impact Factor, Monthly, Peer Reviewed Journal)

Visit: www.ijirset.com

Vol. 7, Issue 11, November 2018

The circuit uses standard power supply comprising of a step-down transformer from 230V to 12V and 4 diodes forming a full-bridge rectifier that delivers pulsating dc which is then filtered. To regulate the dc power supply, IC LM7805 is used to get constant 5V DC.

The regulated 5V DC is further filtered by a small electrolytic capacitor of 2000 μ F for any noise so generated by the circuit. One LED is connected of this 5V point in series with a current limiting resistor of 10 Ω to the ground i.e., negative voltage to indicate 5V power supply availability.

IV. CONCLUSION

In manufacturing and process industries, the variable frequency is required for driving various electrical machineries. The study mainly focuses on the design and construction of the single phase cycloconverter. The commercially designed single phase cycloconverter circuit may use different design pattern than this one. This single phase cycloconverter circuit can be extended further for three phase application. In case of the three phase cycloconverter, each of the positive and negative converter group operates for half the period of the output frequency.

REFERENCES

1. Sathish Bakanagari et al Int. Journal of Engineering Research and Applications ISSN : 2248-9622, Vol. 3, Issue 6, Nov-Dec 2013, pp.2159-2164
2. Power Electronics by Singh M D, K B Khanchandani, second edition, The McGraw Hill Companies.
3. Datasheets of components.
4. J. Zhang, "Single phase input cycloconverters driving an induction motor" Ph.D. thesis, University of Technology, Sydney.
5. G. L. Arsov, "Improvements in microcomputer-based digital control of cycloconverters", IEEE Trans. Ind. Appl., vol. IA-30, no. 3, pp. 585-588, May/June 1994.
6. J. Zhang, G.P. Hunter and V.S. Ramsden, "A single phase input cycloconverter driving a three phase motor", 5th European Conference on Power Electronics, EPE'93, Brighton, UK, 14-17 September 1993
7. V.S. Ramsden, G.P. Hunter and J. Zhang "Impact on the power system of single phase input cyclo converter motor drives" IEE Proc.-Electr. Power Appl., Vol. 142 No. 3, May 1995, pp 176-182.
8. H. Li, B.Ozpineci and B.K.Bose, "A Soft-Switched High Frequency Non-Resonant Link Integral Pulse Modulated DC-DC Converter for AC Motor Drive". Conference Proceedings of IEEE-IECON, Aachen/Germany, 1998, vol. 2, pp 726.
9. B. R. Pelly, Thyristor Phase-Controlled Converters and Cycloconverters, Wiley, New York, 1971.
10. C. Zanne, J.F. Aubry, *Une méthode de conception des systèmes de commande numérique pour une classe de processus rapides*, pp. 435-456.
11. J. P. Louis, A Djerroud, C. Bergmann, "A new method for direct digital control of thyristors converters. Presentation Modeling", *IMACS'91 Proceedings*, vol. 4, pp. 70-76.
12. P. Malléus, C. Zanne, J-F. Aubry, "Design of the Control of a Cycloconverter with Improved Transient Performances", *IEEE/KTH Stockholm Power Tech Conference*, 1995-June-18-22.