

# Outline of Transport Following and Fuel Observing Framework

Usha B H<sup>1</sup>, M R Harshitha<sup>2</sup>, B R Rakshitha<sup>3</sup>, Dr K S Jagadeeshgowda<sup>4</sup>

U G Student, Department of Computer Science, Sri Krishna Institute of Technology, Bengaluru, India<sup>123</sup>

Professor, Department of Computer Science, Sri Krishna Institute of Technology, Bengaluru, India<sup>4</sup>

**ABSTRACT:** Fuel checking has turned into the significant issue that the majority of transport organization proprietors are hoping to settle. The requirement for open transportation framework, for example, transports is quickly expanded because of the expanding in public, the travellers need to know the entry time of the specific transport to specific station and after that arrangement their adventure from their home This paper depicts the advancement of the plan of transport following and fuel checking framework and speed framework to grant an answer for the administration necessities by the executive. The proposed is framework in light of Micro Controller, GSM/GPS and guide suit ASP. This configuration likewise empowers the proprietor of the transports to the keep persistent record the transport so that the on the grounds that framework administrator can without much of a stretch keep up database data of transports and its fuel tank whenever of the administration.

**KEYWORDS :** Bus track, micro controller, GPS, GSM, Fuel Sensors, Accelerometer

## I. INTRODUCTION

To make the general population alarm from not missing the transport and could reach on time to get the transport the framework utilizes GPS module to get the transport scope and longitude esteems. These qualities are gathered from various transport stops and are spared in a program. The GSM modem is associated with Micro Controller board. What's more, the capacity of GSM modem is utilized to send and receive SMS .Travellers versatile numbers are gathered and spared to give an alarm message utilizing AT orders in the outlined code . At the point when the GPS module sends the area the qualities they are contrasted and gathered scope and longitude esteems. In the event that they are same an alarm message is sent to the particular travellers in the forthcoming stops through GSM systems. This framework gives the correct confinements of the followed transport with the minimal effort. This portrays a down to earth show for directing and following with the transport vehicle in expansive zone open air condition in view of GPS and GSM. Furthermore, the fuel burglary is likewise controlled by utilizing the fuel sensors. Accelerometers are utilized controlling the rash driving of the drivers.

In this article we propose an outline Of Bus following and Fuel Monitoring System. The principle commitment of this article are:

- This following framework sends us the topographical co-ordinates and by utilizing this co-ordinates we can track the transport position on Google Map utilizing web.
- The primary advantage is to spare the season of the travellers and fuel utilization.
- It's exceptionally helpful for the travellers as they don't squander the time.
- And accelerometers are utilized to stay away from rash driving of the vehicles by the drivers.
- Fuel Sensors are additionally is utilized to keep away from the burglary of the fuel done by the specific drives.

## II. RELATED WORK

**In Paper [1]** A huge number of Student need to make a trip from their home to class/College consistently. More secure transportation of school kids has been a noteworthy issue as it is frequently watched that the youngsters get themselves,

and the area of the transport area will be distinguished by utilizing GPS, which is send through the Android cell phones. Which will demonstrate the correct area of the transport. In the event that the transport draws close to some specific separation or day and age android application will alarm them by means of sound. Right off the bat the GPS ceaselessly takes input information from the satellite and stores the scope and longitude esteems in microcontroller's cradle.

**In Paper [2]** Constant Web Based Bus Tracking System view of the sudden increment in the populace, there is a necessity for the powerful open transportation framework. Since there is additionally an expanded weight on open transportation like transport on account of populace. In this way the remote client needs a brilliant framework which gives continuous data of the transport entry. So we planned another framework which settle the disadvantage of current open transportation framework. So our proposed framework handle every one of the information like current area of transport , administration of transports and its calendar.

**In paper [3]** GSM based continuous transport entry of the framework .This paper offers the model execution of an ongoing transport landing data framework. The framework centres upon continuous transport tasks data which incorporates the present area and assessed landing time of the following stop, and disperses the data to people in general with an end goal to decrease travellers holding up time. Vehicle-mounted units and transport station units comprises this framework. The vehicle unit reports the present position of the vehicle to the transport station unit and this data is shown to the travellers at the quits utilizing station units.

**In paper [4]** Brilliant following framework for the School transports utilizing the uninvolved RFID innovation to expand tyke security. As a huge number of kids should be moved from their home to class and the other way around consistently. For each parent this has turned into the real issue getting a sheltered transport for their youngsters is a basic issue. Numerous kids get themselves secured a school transport in the transport parking area subsequent to nodding off on their approach to class, miss the transport, venture into the wrong transport, or leave at the wrong station with no strategy to track them.

**In Paper [5]** Sensor choice in remote sensor systems the fundamental target of numerous sensor systems is to give precise data about a detecting field for a real timeframe. This requires gathering estimation from the same number of sensors as much conceivable to have a superior perspective of the sensor environment. In any case, because of vitality constraints and for the long system lifetime the quantity of dynamic sensors ought to be kept to a base. In this paper, we overview distinctive plans that are utilized to choose sensors. In light of the motivation behind determination, we characterize the plans into (1) scope plans, (2) target following and confinement plans, (3) single errand task plans and (4) different undertaking task plans. Choice plans are utilized to track and the localization plans.

### III. SYSTEM ARCHITECTURE

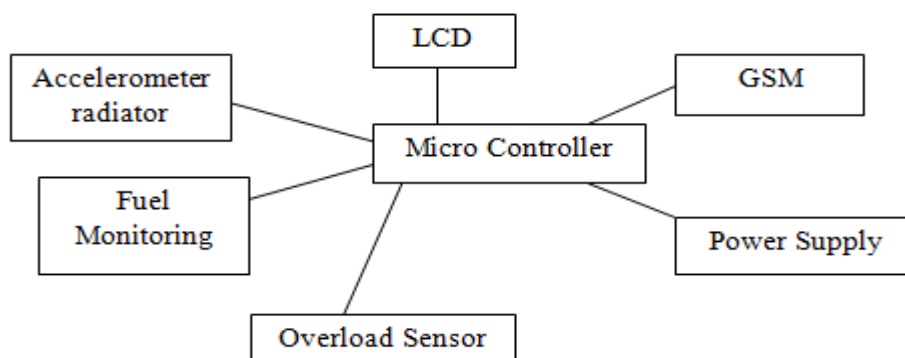

Fig 1: Proposed System Architecture

This paper built up a transport following and checking the fuel and speed framework to give an office to the administration prerequisites by the overseer. The proposed framework in view of Micro Controller, GSM/GPS , which give the impelled landing time notwithstanding graphically demonstrating the transport area on Google outline. The outline likewise empowers the proprietor of the transports to screen the transport immediately on the grounds that the framework chairman can without much of a stretch kept up database data of transports and its fuel tank whenever of the administration.

The design of the framework is appeared in fig.1. It gives the transport landing time contingent upon the client source and goal. The general results usefulness of the framework originates from the communication between the framework segments, which are a gadget on the transport, web application and work area application. A gadget on the transport comprise of microcontroller, GPS, GSM, fuel sensor and speed sensor. You can use AT Command to get data in SIM card. The SIM interface underpins the usefulness of the GSM. The SIM interface is controlled from an inner controller in the module having ostensible voltage 2.8V. All pins reset as yields driving low.

The proposed architecture consists of :

1. Micro Controller : A micro controller is a compact IC designed to govern a specific operation in an embedded system.
2. LCD : LCD is a flat panel display.
3. GSM : Used for the purpose of sending , receiving and calling purpose.
4. Power Supply : It is a source of electrical power.
5. Overload Sensor : Use to sense if there is any overload in the bus.
6. Accelerometer Radiator : This device will sense when there is a rash driving .
7. Fuel Monitor Sensor : It will sense when there is a change in the level of the fuel in the tank.

#### Power Supply :

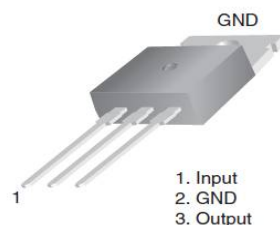

Fig 2: Power Supply

An AC to DC connector as been utilized to get DC contribution for the mother board. In mother board, we have built up a 5V controller circuit, which is required for microcontroller as supply voltage. IR transmitters are likewise associated with 5V supply, so they generally transmit high flag. Power supply is the wellspring of electrical power. Typically we utilize +12V DC control for customary working of any electronic circuit.

#### Overload Sensor:

Travellers over-burden out in the open transports has been a noteworthy issue. Numerous individuals lose their lives and some extremely harmed when mishaps happen in the general population transports. Conveying a larger number of individuals than the limit of the transport prompts crush individuals in the spaces between the seats. To stay away from such circumstances an over-burden sensor gadget is kept to detect it when the sensor sense it consequently shuts the entryway . So over-burden of travellers can be diminished.

13<sup>th</sup>-14<sup>th</sup> March 2018

Organized by

Departments of Computer Science & Information Science Engineering, Sri Krishna Institute of Technology, Bangalore, India

### Accelerometer Radiator:



Fig 3: Accelerometer Radiator

The ADXL335 is a little thin low power, finish 3-pivot accelerometer with a solitary molded voltage yields. The item measures speeding up with a base full-scale scope of +3g. It can quantify the static quickening of gravity in detecting applications, and dynamic increasing speed coming about because of movement, stun or vibration. The client chooses the data transmission of the accelerometer utilizing the Cx , Cy, and Cz capacitors at the Xout ,Yout and Zout pins. Transfer speed can be chosen to suit the application, with organize of 0.5Hz to 1600Hz for X and Y pivot and a scope of 0.5 Hz to 550Hz for the Z hub.

### Fuel Monitor Sensor :



Fig 4 : Fuel Sensor

Basically protected gives a brilliant capacitive sort of fuel sensor. The client simply needs to bolster the limit of the tank and mileage of the vehicle .This gadget is exceptionally savvy and can figure fuel utilization and amount. It will produce an alarm message to the client is any control with your fuel. Fuel robbery control is completed in fact correspondingly to powering control.GPS GPS beacon introduced on transport gets information about changes of fuel level in the tank from fuel level sensor. Proprietor gets a message of the unapproved fuel depleting very quickly. Just protected GPS tracker gadget picks up fuel utilization information straightforwardly from transport fuel sensor so as keep away from the abuse.

## IV. IMPLEMENTATION

Let us consider a scenario as shown in Fig.5 where the commuter keys in routed number of bus from the current location to know the location of bus and expected time of arrival to commuter's location. Once keyed in, the mobile communicates with server of Bus Company to pull up the current location of bus along with route and expected time of arrival of bus to commuter's mobile handset via GMAP as shown in Fig.6 . Fig.6 shows the location of Bus route id 19-Ax at toll booth and expected time of arrival of bus to commuter's location which is bus stop as shown in Green dot.



**Fig 5: Bus Route Selection**



**Fig 6: Bus Location and Expected Time of Arrival**

## V. EXPERIMENTAL RESULTS

Thus a bus running in a particular route will have a transmitter module installed inside it. This transmitter module is what sends the data of the location of this particular bus. Since GSM module is used in both transmitter and receiver module every module will have a unique number. To explain the working of the whole system let us take the map of Coimbatore city. In this map we will mark four points (bus stops) A, B, C and D. A is the starting point of the bus. From the starting point, the bus conductor/ driver presses the push button provided in the transmitter module inside the bus. This will increment a variable in the module corresponding to a particular location. This variable is now sent as a text message to the bus stops B, C and D. When the receiver module in the points B, C and D receives. This variable is now transmitted to the point C and D. Again upon receiving this variable at point C and D. It will be displayed on the LCD that the bus has now reached point B. This will continue till the bus reaches the point D.



Fig 7: LCD display showing the current position of the bus and expected time

## VI. CONCLUSION

This outline can give the area of the transports of the administration with a blunder under 10m on account of moderate speed and clear condition and the framework give the exact landing time of the transport and give the area of the transport in Google delineate both client and chairman. This proposed framework acknowledges the area, stores it and contrast and current information and conveys an alarm message to understudies. It is appropriate in Educational establishments and associations and overseeing activity in sense urban communities and furthermore travelers before they design their trip. Indeed, even fundamental portable is sufficient to get the message. The GSM organize based Real Time Bus Arrival Information System tracks the present area of the considerable number of transports and shows their landing in various stops in their separate courses for the travellers.

## REFERENCES

- [1] Vigneshwaran.K 1, Sumithra.S2, Janani.R3, "An Intelligent Tracking System Based on GSM and GPS Using Smartphones", IJAREEIE, Vol. 4, Issue 5, May 2015 .
- [2] C. Gaurav, N. Gajra, Real Time Bus monitoring and Passenger Information system, International Journal of Soft Computing and Engineering (IJSCE) ISSN: 2231-2307, Volume-1, Issue-6, January 2012. W. Ross, S. Burns, P. Wu, and D. Jared, "RFID tracking technology applied to testing of transportation construction materials," presented at the 88th Annual Meeting of the Transportation Research Board Washington, D.C., January 11-15, 2009.
- [4] J. Byers and G. Nasser. Utility-based decision-making in wireless sensor networks . In Proceedings of the IEEE Workshop on Mobile and Ad Hoc Networking and Computing, 2000.
- [5] Dr.SayleeGharge, ManalChhaya, GauravChheda, JiteshDeshpande, "Real time bus monitoring system using GPS," An International Journal of Engineering Science and Technology, Vol. 2, Issue 3, June 2012.