

International Journal of Innovative Research in Science, Engineering and Technology

(A High Impact Factor, Monthly, Peer Reviewed Journal)

Visit: www.ijirset.com

Vol. 8, Issue 2, February 2019

Underwater Wireless Communication Using Visible Light LEDs

C.Mahendran¹, K.Nandha Kumar², V.Jeyamohan³

Assistant Professor, Department of Electronics and Communication Engineering, Gojan School of Business and Technology, Edapalayam, Chennai, Tamil Nadu, India¹

Assistant Professor, Department of Electronics and Communication Engineering, Gojan School of Business and Technology, Edapalayam, Chennai, Tamil Nadu, India²

Assistant Professor, Department of Electronics and Communication Engineering, Gojan School of Business and Technology, Edapalayam, Chennai, Tamil Nadu, India³

ABSTRACT: Li-Fi or Light Fidelity refers to 5G Visible Light Communication systems using light-emitting diodes as a medium to high-speed communication in a similar manner as Wi-Fi.[13] In the days where internet has become a major demand, *now a days* people are in a search for Wi-Fi hotspots. Li-Fi or New Life of data communication is a better alternative to Wi-Fi in wireless communication. This paper proposes an underwater parameter monitoring system using wireless communication technique by visible light LEDs in the visible region (375nm-780nm) is used as a medium for data transmission is more secure and achieves high data rates compared to other conventional methods.

KEYWORDS: LED (Light Emitting Diode), Wi-Fi (Wireless Fidelity), Li-Fi (Light Fidelity), VLC (Visible Light Communication), RF (Radio Frequency).

I. INTRODUCTION

The concept of Li-fi is currently attracting a great deal of interest, not least because it offers a genuine and very efficient alternative to RF.As a growing number of people and their recent device access wireless internet, the airwaves are becoming increasingly clogged and unavailability of free bandwidths to every device, making it more and more difficult to get a reliable, high speed signal. The opportunity to exploit a completely different part of the electromagnetic spectrum is very appealing. Li-Fi has other advantages over Wi-Fi, such as safe to use at nuclear power plants, thermal power stations where Wi-Fi cannot be used. [5] In such stations RF waves can be harmful and can cause accident, to communicate in such regions only visible light spectrum can be safe. Apart from adverse regions Li-fi can also be used in all places where Wi-Fi can be used.

Li-fi is present wherever there is availability of light, in turn eradicating the necessity of having hot-spots only at selected places. There are four criterions to judge on the working of Li-Fi and Wi-Fi that is, capacity, efficiency, availability and security. Both Li-fi and Wi-Fi uses electromagnetic spectrum for data transmission, but whereas Wi-Fi utilizes radio waves, Li-Fi uses visible light communication in the range of 100Mbps. The present paper deals with the VLC which provide a wide and fast data rate like 500Mbps. In this paper, the comparison is made between Wi-Fi and Li-Fi technology. This paper also discusses the working, implementation and improvements in Li-fi technology. [6]

The Li-Fi technology can be used for various purposes, it matters the data transmission through LEDs thus all the screens which illuminate light can be served as a platform for data communication. The screen of the mobile phone, television, bulbs can act as a source of light. On the other hand, the receiving platform, the photo detector can be replaced by a camera in mobile phone for scanning and retrieving data. Its other applications are Li-fi for desktops, smartcard Li-fi, Li-fi for schools, hospitals, Li-fi in cities, smart guides, museums, hotels, fairgrounds, events indoor and LBS(Location-based Services), access control and

International Journal of Innovative Research in Science, Engineering and Technology

(A High Impact Factor, Monthly, Peer Reviewed Journal)

Visit: www.ijirset.com

Vol. 8, Issue 2, February 2019

identification crisis, malls, airport and dangerous environments like thermal power plants.[3][4]

II. LI-FI COMMUNICATIONS

LI-FI communications with physical layer, modulation formats and frequency spectrum that is related with Li-Fi communication. The IEEE 802.15.7 standard defines the physical layer (PHY) and media access control (MAC) layer. The standard is able to deliver enough data rates to transmit audio, video and multimedia services. It takes into account the optical transmission mobility, its compatibility with artificial lighting present in infrastructures, the deviance which may be caused by interference generated by the ambient lighting. The MAC layer allows using the link with the other layers like the TCP/IP protocol.

The technology is ideal for wireless docking, data links with kiosks and mobile displays, medium-range beaming, data Showers and optical cellular networks. Users will be able to enjoy a wireless RF-free user environment with data rates that can transfer a 2-hour HDTV video in less than 30 seconds and wirelessly link their bus-connected heavy-lifting peripheral cabinets located elsewhere in the room.[11] For communication purpose light wave carry data in a fast manner, but in radio wave the data transfer rate is slow. So for that reason we are looking for light wave communication.

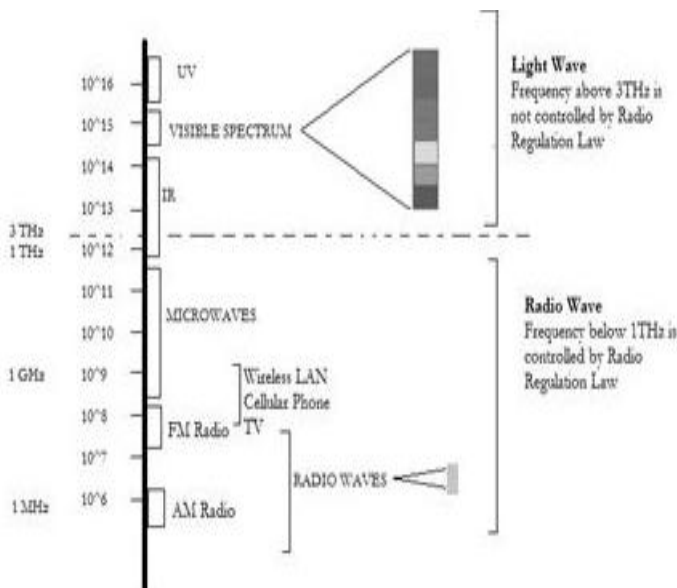

Fig1: LIFI Technology

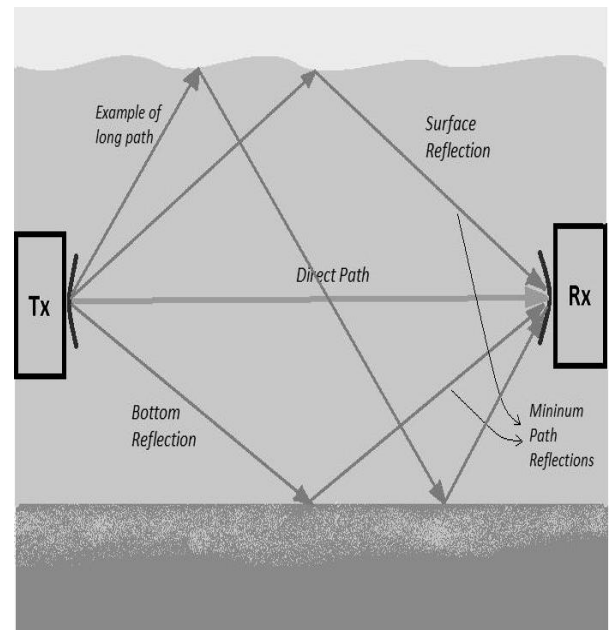

Fig2: Under water communication

Underwater acoustic communication is a technique of sending and receiving messages below water.[1] There are several ways of employing such communication but the most common is by using hydrophones. Underwater communication is difficult due to factors such as multi-path propagation, time variations of the channel, small available bandwidth and strong signal, especially over long ranges. Compared to terrestrial communication, underwater communication has low data rates because it uses acoustic waves instead of electromagnetic waves.

In this paper, we propose an underwater parameter monitoring system using wireless communication technique by visible light LEDs in the visible region (375nm-780nm) is used as a medium for data transmission is more secure and achieves high data rates compared to other conventional methods. Thus, the research of new underwater wireless

International Journal of Innovative Research in Science, Engineering and Technology

(A High Impact Factor, Monthly, Peer Reviewed Journal)

Visit: www.ijirset.com

Vol. 8, Issue 2, February 2019

communication techniques has played the most important role in the exploration of oceans and other aquatic environments. In contrast with terrestrial wireless radio communications, the communication channels in underwater wireless networks can be seriously affected by the marine environment, by noise, and by limited bandwidth and power resources, and by the harsh underwater ambient conditions. Hence, the underwater communication channel often exhibits severe attenuation, multipath effect, frequency dispersion, and constrained bandwidth and power resources, etc., which turn the underwater communication channel into one of the most complex and harsh wireless channels in nature.

III. HARDWARE SETUP

Block Diagram

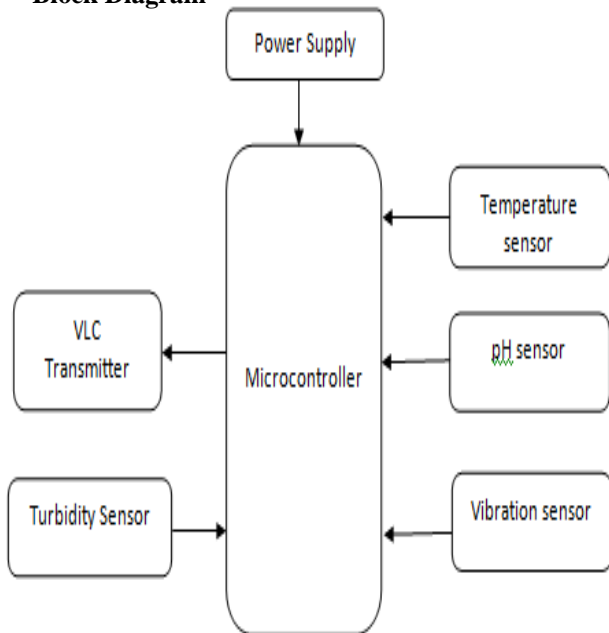

Fig3: Under water Node

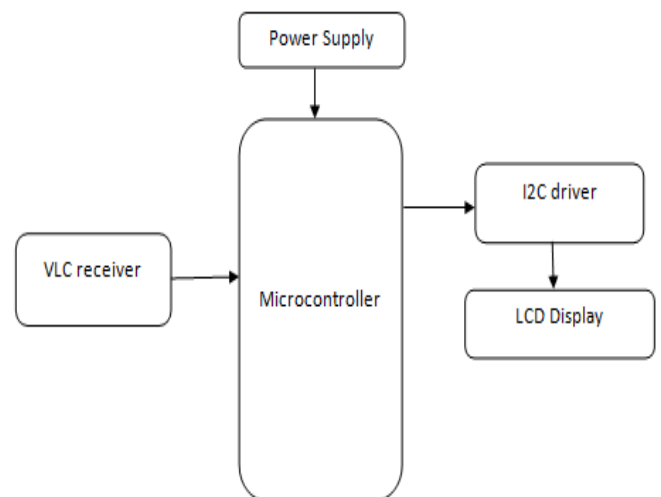

Fig4: Server node

PIC microcontroller

- Timer1 Oscillator/w RTCC: 1 μ A, 32 kHz
- Watchdog Timer: 2.2 μ A, 2V Typical.
- 5.5V Tolerant Inputs (digital only pins)
- Low-Power, High-Speed CMOS Flash Technology
- Priority Levels for Interrupts
- Self-Programmable under Software Control
- 8 x 8 Single-Cycle Hardware Multiplier
- Extended Watchdog Timer (WDT)
- 5 Ports A,B,C,D,E
- Timers- 5

International Journal of Innovative Research in Science, Engineering and Technology

(A High Impact Factor, Monthly, Peer Reviewed Journal)

Visit: www.ijirset.com

Vol. 8, Issue 2, February 2019

Ph Measurement

A pH measurement loop is made up of three components, the pH sensor, which includes a measuring electrode, a reference electrode, and a temperature sensor; a preamplifier; and unanalyzed or transmitter. A pH measurement loop is essentially a battery where the positive terminal is the measuring electrode and the negative terminal is the reference electrode. The measuring electrode, which is sensitive to the hydrogen ion, develops a potential (voltage) directly related to the hydrogen ion concentration of the solution. The reference electrode provides a stable potential against which the measuring electrode can be compared.

When immersed in the solution, the reference electrode potential does not change with the changing hydrogen ion concentration. A solution in the reference electrode also makes contact with the sample solution and the measuring electrode through a junction, completing the circuit. Output of the measuring electrode changes with temperature (even though the process remains at a constant pH), so a temperature sensor is necessary to correct for this change in output. This is done in the analyzer or transmitter software.

The pH sensor components are usually combined into one device called a combination pH electrode. The measuring electrode is usually glass and quite fragile. Recent developments have replaced the glass with more durable solid-state sensors. The preamplifier is a signal conditioning device. It takes the high-impedance pH electrode signal and changes it in to allow impedance signal which the analyzer or transmitter can accept. The preamplifier also strengthens and stabilizes the signal, making it less susceptible to electrical noise.

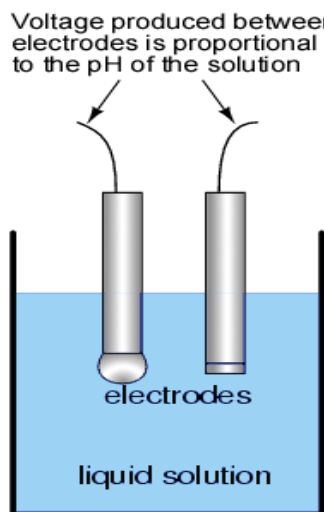
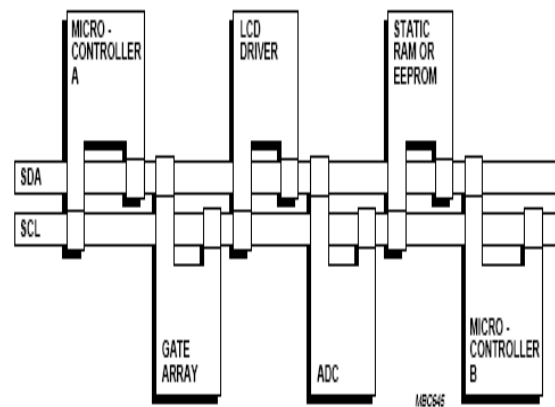

Fig5: Ph Measurement



Example of an I²C-bus configuration using two microcontrollers.

Fig6: Ph Measurement

The design and operational theory of pH electrodes is a very complex subject, explored only briefly here. What is important to understand is that these two electrodes generate a voltage directly proportional to the pH of the solution. At a pH of 7 (neutral), the electrodes will produce 0 volts between them. At a low pH (acid) a voltage will be developed of one polarity, and at a high pH (caustic) a voltage will be developed of the opposite polarity.

FEATURES OF LCD

- Operating voltage range is 3-20V ac.
- Response time is 50 to 200 ms.
- Viewing angle is 100 degree.

International Journal of Innovative Research in Science, Engineering and Technology

(A High Impact Factor, Monthly, Peer Reviewed Journal)

Visit: www.ijirset.com

Vol. 8, Issue 2, February 2019

- Invisible in darkness. Requires external illumination.
- Life time is limited to 50,000 hours due to chemical graduation
- **I²C Protocol**

The I²C -bus is a multi-master bus. This means that more than one device capable of controlling the bus can be connected to it. The possibility of connecting more than one microcontroller to the I²C -bus means that more than one master could try to initiate a data transfer at the same time. To avoid the chaos that might ensue from such an event - an arbitration procedure has been developed. This procedure relies on the wired-AND connection of all I²C interfaces to the I²C -bus. If two or more masters try to put information onto the bus, the first to produce a 'one' when the other produces a 'zero' will lose the arbitration. The clock signals during arbitration are a synchronized combination of the clocks generated by the masters using the wired-AND connection to the SCL line. Generation of clock signals on the I²C -bus is always the responsibility of master devices; each master generates its own clock signals when transferring data on the bus. Bus clock signals from a master can only be altered when they are stretched by a slow-slave device holding-down the clock line, or by another master when arbitration occurs.

IV. PROPOSED SYSTEM

Visible light communication (VLC) based underwater communication, which uses visible light between 400 THz (780 nm) and 800 THz (375 nm) as optical carrier for data transmission and illumination. It uses fast pulses of light to transmit information wirelessly.

VLC uses white Light Emitting Diodes (LED), which send collected data by flashing light at speeds undetectable to the human eye. One major advantage of VLC is that we can use the infrastructure around us without having to make any changes to it. LEDs' ability to transfer information signals over light (light which is between 400THz to 800THz of frequency and whose wavelength is between 400nm to 700nm) makes it a very good communication medium. The LED lighting system can achieve lower power consumption and has a longer life-time compared to the fluorescent lamp system.

V. RESULTS OBTAINED

- The performance of the system is assessed based on two key elements: sensor reliability and communication reliability.
- Data was determined as correct based on the physical behavior of the subject under test in a controlled environment.
- The sensor reliability was calculated by finding the ratio of the number of correct data (right status under the controlled environment tests) received to the total number of received data.
- Severe damage and failures can be avoided and treated properly without much cost and reliable approach to solve the problem.

VI. CONCLUSION

Our ultimate goal is to reduce time consumption for evaluating the results. Also to avoid the manual work involved in this process. Microcontroller is used to monitor the result properly and send the result to authorized person. Embedded systems are rapidly growing in all sectors. So by using real time embedded systems can achieve the auto self-monitoring and alert system efficiently and accurately. The future we can enhancement by connecting to the internet server and can control the industries water which is supplied to the industries and control the wastage of water and increases overall project efficiency. Since all the industries are connected in network we can identify and take action on individual industries

The challenges and difficulties of deployment of sensors and IEEE801.15.4 protocol in practical scenarios have been identified. Measured the performance of the sensors based on battery life as well as communication and sensing

International Journal of Innovative Research in Science, Engineering and Technology

(A High Impact Factor, Monthly, Peer Reviewed Journal)

Visit: www.ijirset.com

Vol. 8, Issue 2, February 2019

reliabilities.

The proposed work has overcome the disadvantages of the existing scheme.

REFERENCES

- [1] S.Fahn, R. L. Elton, U. D. Committee et al., "Unified Parkinson's disease rating scale," *Recent Dev. Parkinson's Dis.*, vol. 2, pp. 153–163, 1987.
- [2] Y. Y. Goh, B. Ho, and J. L. Ding, "A novel fluorescent protein-based biosensor for gram-negative bacteria," *Appl. Environ. Microbiol.*, vol. 68, no. 12, pp. 6343–6352, 2002.
- [3] <http://lifcenter.net/solutions/lifi-solutions>
- [4] <http://en.wikipedia.org/wiki/Li-Fi>
- [5] <http://www.authorstream.com/Presentation/2anu3-1740372-li-fi-technology/>
- [6] <http://www.scribd.com/doc/133997630/li-fi>
- [7] Y. Zhang, S. S. Koponen, M. T. Hallikainen, and J. T. Pulliainen, "Application of empirical neural networks to chlorophyll—A estimation in coastal waters using remote optosensors," *IEEE Sensors J.*, vol. 3, no. 4, pp. 376–382, Aug. 2003.
- [8] F. Attivissimo, C. G. C. Carducci, A. M. L. Lanzolla, A. Massaro, and M. R. Vadrucchi, "A portable optical sensor for in situ measurements of chlorophyll a and water transparency in seawaters," *IEEE Sensors J.*, 2014, doi: 10.1109/JSEN.2014.2340437.
- [9] Munafò, A.; Simetti, E.; Turetta, A.; Caiti, A.; Casalino, G., "Autonomous underwater vehicle teams for adaptive ocean sampling: a data-driven approach", *Ocean Dynamics* (2011): 1981-1994.
- [10] Caiti, A.; Calabrò, V.; Munafò, A.; Dini, G.; Lo Duca, A., "Mobile Underwater Sensor Networks for Protection and Security: Field Experience at the UAN11 Experiment", *J. Field Robotics* (2013): 30(2), 237-253.
- [11] Hanson, Frank, and Stojan Radic. "High bandwidth underwater optical communication." *Applied optics* 47.2 (2008): 277-283.
- [12] Sari, Hayri, and Bryan Woodward. "Underwater voice communications using a modulated laser beam." *OCEANS'98 Conference Proceedings*. Vol. 2. IEEE, 1998.