



e-ISSN: 2319-8753 | p-ISSN: 2320-6710

IJIRSET

International Journal of Innovative Research in
SCIENCE | ENGINEERING | TECHNOLOGY

INTERNATIONAL JOURNAL OF INNOVATIVE RESEARCH

IN SCIENCE | ENGINEERING | TECHNOLOGY

Volume 10, Issue 3, March 2021

ISSN INTERNATIONAL
STANDARD
SERIAL
NUMBER
INDIA

Impact Factor: 7.512

9940 572 462

6381 907 438

ijirset@gmail.com

www.ijirset.com



FPGA Based Implementation of Core Modified Median Filter for Error Detection

R.S.Ramya.M.E., Midhula.G

HOD, Department of ECE, AVS Engineering College, Salem, Tamil Nadu, India

M.E. Student, Department of ECE, AVS Engineering College, Salem, Tamil Nadu, India

ABSTRACT: Error correction is one of the important techniques for detecting and correcting errors in communication channels, recollections, all types of memories. But the NAND FLASH memories are competing in the market due to its stumpy power, soaring density, cost helpfulness and design scalability. So, various DSP algorithms are used to overcome the delays by increasing the sampling charge. BCH codes are extensively been worn for error recognition and rectification. In the proposed scheme, both syndrome calculator and encoder are combining implemented. Linear Feed Back Shift Register (LFSR) are used to implement the design of encoder for polynomial division and the decoder design is based on inversion-less Berlekamp-Massey algorithm (BMA), Chien search algorithm and syndrome calculator. The main improvement of LFSR is that it operates at high speed, but its main drawback is that the inputs are prearranged in bit serial. To prevail over these drawbacks, DSP algorithms such as Selecting a better unfolding value reduce the mock-up period, decrease the clock succession, and increases the speed, power and the throughput.

KEYWORDS: BMA, Built-in-Self-Test, DPBM, NAND FLASH.

I. INTRODUCTION

VLSI stands "Very Large Scale Integration". The field which involves packing more logic devices into smaller areas. VLSI devices are used in your computer, your car, your brand new state-of-the-art digital camera, the cell-phones, and what enclose you. Everyone this involve a lot of expertise on many fronts within the same field. VLSI has been roughly for a protracted time, there is zilch new about it but as a side effect of advances in the world of computers, in attendance has been a dramatic production of tools that can be used to design VLSI circuits. Alongside, obeying Moore's law, the aptitude of an IC has augmented exponentially over the years. In terms of computation power, utilization of available area, yield. The united achieve of these two advances is with the aim of people can put different functionality into the IC's, open new frontiers. These two fields are kind a related and their description can easily getting into another article.

Polynomial basis multipliers

Polynomial basis multipliers operate polynomial basis and no origin converters required. These multipliers are by far implemented, because of hardware efficient and the time to produce the outcome is the alike as for Berlekamp or Massey-Omura multipliers. The bit-serial polynomial basis multipliers are operate serial-in parallel-out multipliers. In several applications, additional register being obligatory is the result and adds an superfluous m clock cycles to the totaling time. This is the main reason why polynomial basis multipliers are habitually disregarded for use in code design.

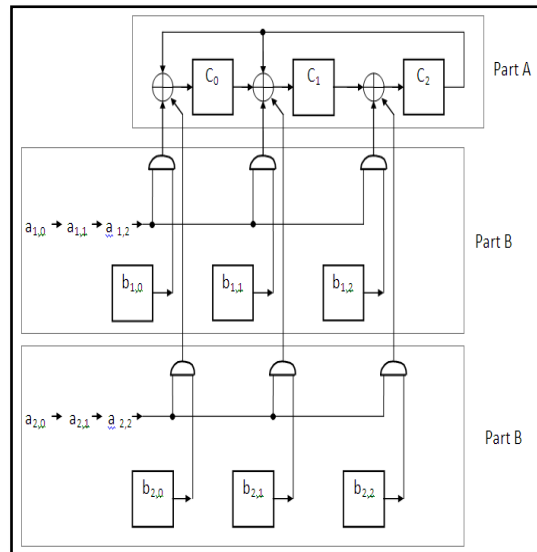

Fig 1 Polynomial basis multipliers

DPBM:

The DPBM is particularly useful if the time taken to generate a product is critical. The DPBM offers a half-way solution between a bit-serial and a bit-parallel multiplier. Both DPBMs are used to make hardware efficient and in some situations the DPBM offers a reduction in hardware since the intermediate value z does not have to be stored. The structure of the DPBM depends on the irreducible polynomial for $GF(2^m)$.

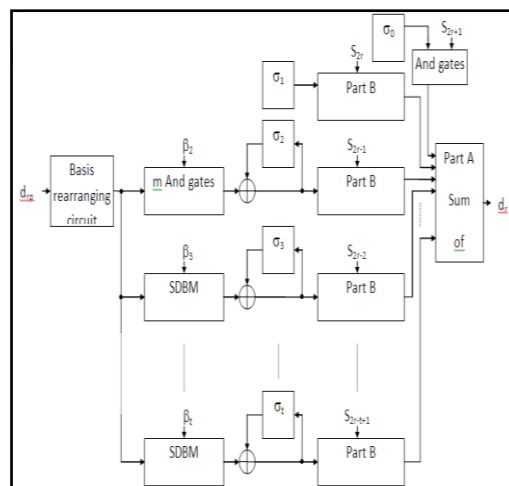

Fig 2. DPBM

II. SURVEY

A. High Throughput LFSR Design for BCH Encoder using Sample Period Reduction Technique for MLC NAND based Flash Memories.

Errors that transpire in MLC NAND based flash memories a choice of coding techniques can be functional for error detection and correction. There is an assortment of codes available for error detection and correction. The codes are divided into two types; 1). conventional code and 2). block codes Cyclic code is one of the classifications of block codes. The rift of the block code is BCH code. BCH code initially forms a generator polynomial by the use of finite field (GF) concept and generates a parity (check) bits to be appended to the message bits to form a codeword. Unfolding is a renovation modus operandi, which describes J consecutive iterations of the original DSP algorithm. It

increases the several Iteration bound to J . In order to trim down the sampling period it is important to calculate the iteration bound ahead of unfolding the system to select the unfolding factor.

B. MPCN-Based Parallel Structural design in BCH Decoders for NAND Flash Memory Devices

This brief has provided a novel MPCN-based parallel structural design in long BCH decoders for NAND Flash memory plans. Different previous approaches performing CFFMs calculations, the proposed design has exploited MPCNs to improve the hardware efficiency since one MPCN require the XOR gate requirement is at most $m - 1$, whereas that of one CFFM is usually proportional to m .

The future MPCN-based structural design can combine the syndrome calculator and the Chien search leading to significant hardware reduction. The parallel-32 BCH (4603, 4096; 39) decoder contrast to design ,the proposed combine Chien search and syndrome calculator has gate count saving 46.7% according to the combination results in the CMOS 90-nm technology.

C. A Fully Parallel BCH Codec with Double Error Correcting neither Capability for NOR Flash Applications

Double error correcting (DEC) BCH codes are necessary; however, their iterative processing are not suitable for the latency-constrained memories. Thus, fully parallel architecture is proposed in this paper at the cost of increasing area. New method is to combine encoder and syndrome calculator by using matrix operations developed. In addition to reduce the degree of error location polynomial, a new error location polynomial is defined. so that the hardware cost in Chien search will be sufficiently reduced.

D. An Area Efficient (31, 16) BCH Decoder for Three Errors

BCH codes are one of the most powerful error-correcting codes used to correct errors occurred during the transmission of the data. This paper presents a low complexity and area efficient error-correcting BCH decoder used to for detect and correct three errors occurred during transmission. The advanced Peterson error locator algorithm computation, which reduces calculation complexity is proposed for the IBM block in the (31, 6) BCH decoder. syndrome calculator and chien search are modified to reduce hardware complexity. The design methodologies of the BCH decoder models have considerably low hardware complexity and latency than those using conventional algorithms. The proposed BCH decoder (31, 16) over GF (5), leads to a reduce the complexity compared to that of conventional BCH decoder.

E. Encoder And Decoder For (15,11,3) and (63,39,4) Binary BCH Code With Multiple Error Correction.

There are numerous types of error amendment codes based on the type of error expected, the communication medium and weather re-transmission, etc. various of the Error correction codes, which are widely used these days, are BCH, Turbo, Reed Solomon, and LDPC. These codes are unusual from each other in their complexity and implementation it is highly doable that the data or message get corrupted for the period of transmission and reception through a noisy channel. To get the error free communication need Error correction code.

F. An Enhanced (15, 5) BCH Decoder Using VHDL

This scheme covers the full clarification about the necessity of Error correcting code along with the comparison of several error correcting codes and (15, 5) high clock speed BCH code Encode and Decode design. The preceding confers encoder and decoder the design method and the designs behavior of the is described using Verilog. The simulation of the code is done in Xilinx Modelsim. Also, the synthesis of encoder and decoder design is done in Xilinx ISC 14.3 wabepack to generate the gate level results. This design step follow input signals and output signals along with the simulation results of design and synthesis result are discussed.

G. Implementation of Parallel BCH Encoder Employing Tree-Type Systolic Array Architecture.

In this system Basically NAND type is used as high density data storage, whereas NOR category is worn for code storeroom and unswerving effecting. The decoding letdown reported is the cipher of errors exceeded the intended aptitude of the ECC circuits. In a flash memory, the read in addition to write operations of data are conducted in bytes at apiece clock cycle. Accordingly, byte-wise parallel encoding and decoding shall be preferred for high-speed flash memories. The presumption of error detecting and correcting codes deals through the unswerving storage of data. Information media is not utterly unswerving in practice since the noise habitually causes data to be distorted. In particular, BCH code for compound error amendment is broadly used in MLC flash memory. in the main, BCH encoder can be implemented whichever by hardware or software methods. from the time when software implementation of BCH code cannot accomplish the considered necessary limited speed, the hardware design is preferred for high-speed applications.



H. High-speed Parallel Structural design and Pipelining for LFSR

The mathematical proof to show that a transformation exists in state space. By which help can reduce the complexity of the parallel LFSR feedback loop. This paper present a new novel method for high speed parallel completion of linear feedback shift register based on IIR filtering and this is the proposed method. This proposed method can reduce the critical path and the hardware cost at the same time. This design is appropriate for any type of LFSR structural design. In the combined pipelining and parallel processing technique of IIR filtering, critical path in the feedback part of the design can be reduced. For the future work can use this proposed design with combined parallel and pipelining for long BCH codes.

I. A Novel Method Implementation of a FPGA using (n, k) Binary BCH Code

The mixture and timing simulation, shows the (15, 5, 3). According to requirement of the speed, BCH Encoder and decoder are advantageous over the other two method. It can correct error 3 at the receiver side when the original data corrupt by the noise. But when allowing for area then (15, 11, 1) is better which can correct only 1 bit error. Also redundancy is less and data rate is large in it. BCH codes have to be excellent error correcting codes among codes of short lengths. They are relatively simple to encode and decode. Due to these qualities, there is much interest in the exact of these codes. The device utilization and speed can be improved by adopting parallel approach methods.

J. Improved Error Correction Capability in Flash Memory using Input / Output Pins

Thus the technique is found to be useful and efficient in inaccuracy correcting in the product codes, design that for 8 and 16 kB page sized memories, regular product schemes achieve one decade lower BER when raw BER ranges from to compare to plain RS codes or BCH code with similar code length. A comparison of the area, latency, additional storage shows that product schemes have lower hardware and latency than RS codes. The bit error rate is reduced by introducing I/O pins by reduce the programming cycles.

III. COMPARISON TABLE

S.no	Methodology	Advantage	Disadvantage
1	Unfoldig dsp Algorithm	Reduce the encoder delay ,high throughput	High power consumption, Reduce area efficient
2	Peterson's algorithm, Berlekamp Massey Algorithm	Area efficient, Speed efficient	Power is high
3	Peterson's algorithm, Berlekamp-Massey(BM) algorithm	To improve reliability	It is not suitable for latency-constrained memories.
4	Used the linear feedback shift register for polynomial division encoder	Correct 4 errors at the receiver side when the original data is corrupted by the noise.	Multiple bit upset (MBU) errors is likely to increase



IV. CONCLUSION

Since the NAND FLASH memories require less delay encoders, a high throughput encoder is premeditated by unfolding the LFSR of the BCH encoder by scrutiny design criteria for selecting the unfolding factor. Moreover area, clock cycle and power is analyzed by simulating the design. The obtained results reveal that unfolding increases the throughput, this in turn decreases the timer cycle which automatically increases the speed but it increases the area and power. various-pipelining techniques can be introduced to reduce the critical path of the encoder of BCH. Retiming also can be functional to advance increase the speed and to reduce the power consumption and area.

REFERENCES

1. Manikandan.S.K,Nisha Angeline. M, Sharmitha.E.K, Palanisamy. C “High Throughput LFSR Design For Bch Encoder Using Sample Period Reduction Technique For MLC NAND Based Flash Memories”International Journal Of Computer Applications (0975 – 8887) Volume 66– No.10, March 2013.
2. Yi-Min Lin, Chi-Heng Yang, Chih-Hsiang Hsu, Hsie-Chia Chang, And Chen-Yi Leea “Mpcn-Based Parallel Architecture In BCH Decoders For Nand Flash Memory Devices” IEEE Transactions On Circuits And Systems— Ii: Express Briefs, Vol. 58, No. 10, October 2011.
3. M. Prashanthi, P. Samundiswary2 “An Area Efficient (31, 16) Bch Decoder For ThreeErrors” International Journal Of Engineering Trends And Technology(IJETT)-Volume 10 Number 13-Apr 2014.
4. Chia-Ching Chu, Yi-Min Lin, Chi-Heng Yang, And Hsie-Chia Chang “A Fully Parallel Bch Codec With Double Error Correcting Capability For Nor Flash Applications” IEEE Transaction ICASSP 2012 978-1-4673-0046-9/12/\$26.00 ©2012
5. R.Elumalai, A.Ramachandran, J.V.Alamelu, Vibha B Raj “Encoder And Decoder For (15,11,3) And(63,39,4) Binary BCH Code With Multiple Error Correction”International Journal Of Advanced Research(An ISO 3297:2007 Certified Organization)Vol.3,Issue 3,March 2014.
6. Rajkumar Goverchav, V.Sreevani “An Enhanced (15, 5) Bch Decoder Using Vhdl” International Journal Of Advanced Research (An ISO 3297:2007 Certified Organization)Vol.3,Issue 11,November 2014
7. Je-Hoon Lee , Sharad Shakya“Implementation Of Parallel Bch Encoder Employing Tree-Type Systolic Array Architecture”International Journal Of Sensor And Its Applications For Control Systems Vol.1, No.1 (2013), Pp.1-12.
8. Vinod Mukati “High-Speed Parallel Architecture And Pipelining For LFSR”International Journal Of Scientific Research Engineering & Technology(IJSRET) Issn:2278-0882 IEERET-2014 Conference Proceeding,3-4 November ,2014
9. Mahasiddhaya R Hiremath, Manju Devi “A Novel Method Implementation Of A FPGA Using (N, K) Binary Bch Code” International Journal Of Research In Engineering Technology And Management ISSN 2347 – 7539 IJRETM-2014-Sp-008 ,June-2014.
10. J .Shafiq Mansoor, A .M. Kiran “Improved Error Correction Capability In Flash Memory Using Input / Output Pins” International Journal Of Advanced Information Science And Technology(IJAIST)ISSN:2319:2682Vol.12,No.12,April2013.



INNO  **SPACE**
SJIF Scientific Journal Impact Factor

**Impact Factor:
7.512**

ISSN INTERNATIONAL
STANDARD
SERIAL
NUMBER
INDIA



INTERNATIONAL JOURNAL OF INNOVATIVE RESEARCH

IN SCIENCE | ENGINEERING | TECHNOLOGY

 **9940 572 462**  **6381 907 438**  **ijirset@gmail.com**



www.ijirset.com

Scan to save the contact details