



e-ISSN: 2319-8753 | p-ISSN: 2320-6710

# IJRSET

International Journal of Innovative Research in  
**SCIENCE | ENGINEERING | TECHNOLOGY**

# INTERNATIONAL JOURNAL OF INNOVATIVE RESEARCH

IN SCIENCE | ENGINEERING | TECHNOLOGY

Volume 10, Issue 5, May 2021

**ISSN** INTERNATIONAL  
STANDARD  
SERIAL  
NUMBER  
INDIA

**Impact Factor: 7.512**

 9940 572 462

 6381 907 438

 [ijirset@gmail.com](mailto:ijirset@gmail.com)

 [www.ijirset.com](http://www.ijirset.com)

# Nonlinear Analysis of Retaining Wall for Different Soil Condition

Mr. Swapnil Bhaskar Zaware, Dr. M. P. Wagh

PG Student, Department of Civil Engineering, Dr. Vitthalrao Vikhe Patil College of Engineering,  
Ahmednagar, India

Professor, Department of Civil Engineering, Dr. Vitthalrao Vikhe Patil College of Engineering,  
Ahmednagar, India

**ABSTRACT:** These Structural dynamic deals with method to determine the stresses and displacement of structure subjected to dynamic loads .the dimension of structure are finite. This leads to a finite domain for soil which can be modeled similarly to the structure the total discretized system, consisting of the structure and soil, can be analyzed straight forwardly. The process in which the response of the soil influences the motion of the structure and the motion of the structure influences the response of the soil is termed as soil-structure interaction. Hence, the modern seismic design codes, such as Standard Specifications for Concrete Structures: Seismic Performance Verification JSCE 2005 stipulate that the response analysis should be conducted by taking into consideration a whole structural system including superstructure, foundation and ground. In this study nonlinear analysis of retaining wall is studied including soil structure interaction for various types of walls for silty soil, clay soil and sandy soil.

**KEYWORDS:** Dynamic Analysis, Soil Conditions, soil-structure interaction, ANSYS.

## I. INTRODUCTION

### 1.1 Parametric Details

The analysis of a rigid wall with reinforced backfill is carried out by considering the different parameters which are discussed below. Wall geometry: (height of wall and Roadway width) the rigid wall with reinforced backfill technology is suitable particularly for the construction of flyover approach roads and road construction in hilly areas. Hence, height of wall always varying. The width of roadway of 12 m is considered in the present investigation as per IRC: 6 as referred in references.

- **Backfill soil:** As reported in the literature, granular soils are preferred for the construction for reinforced earth walls. They have the advantage of free drainage and also because of higher frictional resistance at the interface of soil and reinforcement; there is no slippage of reinforcement. In the present investigation three types of backfill soils having soil modulus 1.00E+04, 5.00E+04, 1.00E+05 (kPa) as reported in literatures as granular soils are selected for investigation.
- **Soil in foundation strata:** The soil in foundation strata covers large variations from soft and stiff clay to moderate and compact granular formation. Hence, seven types of soils are considered having soil modulus 1.00E+01 to 1.00E+07 (kPa) as reported in literatures.
- **Steel reinforcement:** The reinforcement considered in the analysis is galvanized iron strips of 40 mm wide and cross sectional area of 100 mm<sup>2</sup> placed at 500 mm vertical spacing. The elastic properties of reinforcement assumed in the analysis are: modulus of elasticity ( $E$ ) 200 GPa, and Poisson's ratio ( $m$ ) 0.30

### 1.2 Objectives

- To Study Finite Element Modeling Of Retaining Wall Using ANSYS
- To Validate FEM Model With Approximate Method For Checking Accuracy
- To Compare Various Design Parameter For Retaining Wall In Accordance With IS 456-2000
- To Analyze the behavior of earth retaining structures under seismic conditions
- To check the problem of instability of walls is mainly related to earth pressure distribution on the wall and the response of wall against the earth pressure, especially, under dynamic loading condition.



**1.3 Counterfort Retaining**

The counterfort retaining wall is a type of retaining wall with counterforts attached to the inside face of the wall to further resist lateral thrust and materials used for retaining walls are treated lumber, concrete block systems, stone, brick, and poured concrete. The stem and the base and also base slab are tied together by counterforts at suitable intervals in the counterfort retaining wall and the vertical stem, as well as the heel slab, acts as a continuous slab because of the provision of counterforts.

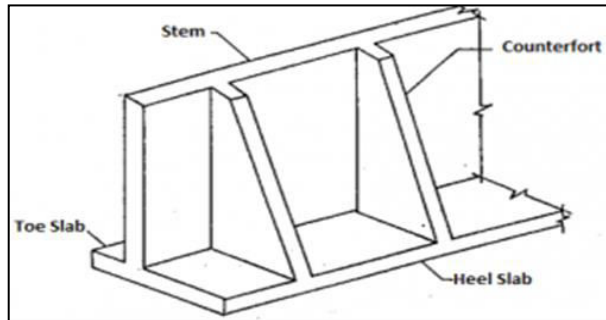

Fig 1 Counterfort Retaining

**1.3 T-Retaining**

T-WALL is a gravity retaining wall system, consisting of modular precast concrete units and select backfill. The system is a simple proven solution for grade separation on highway, bridge, railroad, water, commercial applications, and more. The concrete units are facing with monolithic perpendicular stems, forming the shape of a “T”. The stems internally stabilize the wall, providing pullout resistance against the lateral earth pressure exerted on the back of the facing. The result is a modular gravity structure with no mechanical connections necessary



Fig 2 T-Retaining

**II. PROPOSED METHOD**



**2.1 SSI effects**



Proper consideration of SSI effects in a substructure approach requires: (i) an evaluation of free-field soil motions and corresponding soil material properties; (ii) an evaluation of transfer functions to convert free-field motions to foundation input motions; (iii) incorporation of springs and dashpots (or more complex nonlinear elements) to represent the stiffness and damping at the soil foundation interface; and (iv) a response analysis of the combined structure spring/dashpot system with the foundation input motion applied.

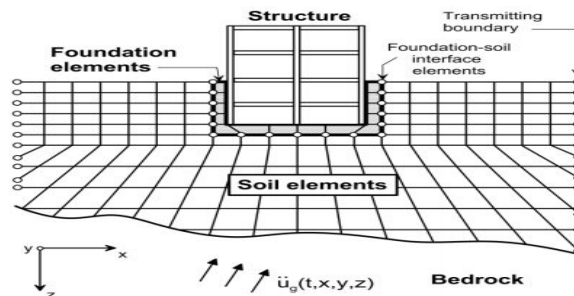

Fig 1 Soil-structure interaction

III. RESULT

SR.NO.	TYPE	SOIL TYPE	SPAN
MODEL NO.1	T-RETAINING WALL	SANDY	45m
MODEL NO.2	T-RETAINING WALL	SILTY	45m
MODEL NO.3	T-RETAINING WALL	CLAY	45m
MODEL NO.4	COUNTERFORT RETAINING WALL	SANDY	45m
MODEL NO.5	COUNTERFORT RETAINING WALL	SILTY	45m
MODEL NO.6	COUNTERFORT RETAINING WALL	CLAY	45m

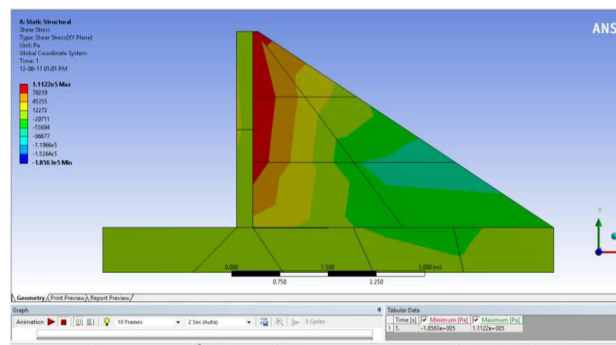

Fig 3 Modeling of Counterfort Retaining Wall

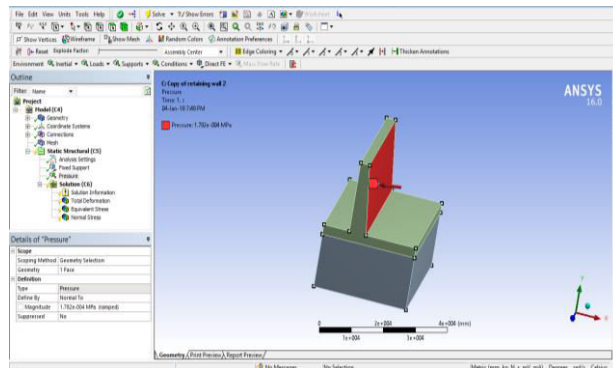
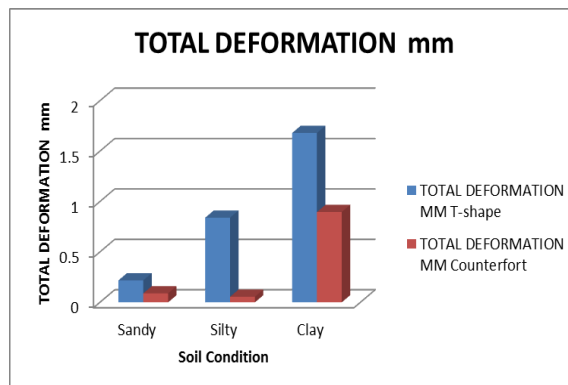

Fig 4 T Shaped Retaining Wall Modeling

3.1 Total Deformation in mm

Table 1 Total Deformation in mm

TOTAL DEFORMATION MM		
Soil type	T-shape	Counterfort
Sandy	0.21849	0.089054
Silty	0.84066	0.055595
Clay	1.68	0.896



Graph 1: Total Deformations in mm

In the above graph the results of the total deformation for the T-shape and counterfort wall for the different soil conditions, as per dam type the Deformation for the counterfort retaining wall is economic than the T shape wall by 20-25%, and as per soil condition Sandy soil have less deformation than silty and clay soil for the both dams

3.2 Equivalent Stress

Table 2 Equivalent Stress

EQUIVALENT STRESS Mpa		
Soil type	T-shape	Counterfort
Sandy	3.56E+10	3.15E+10
Silty	1.22E+11	5.61E+10
Clay	1.97E+11	1.31E+11

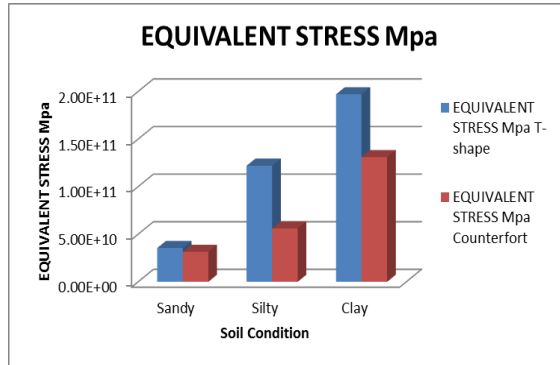

Graph 2: Equivalent Stress

3.3 Shear stress

Table 3 Shear stress

SHEAR STRESS Mpa		
Soil type	T-shape	Counterfort
Sandy	1.03E+09	8.68E+08
Silty	2.12E+09	1.70E+09
Clay	6.12E+09	4.22E+09

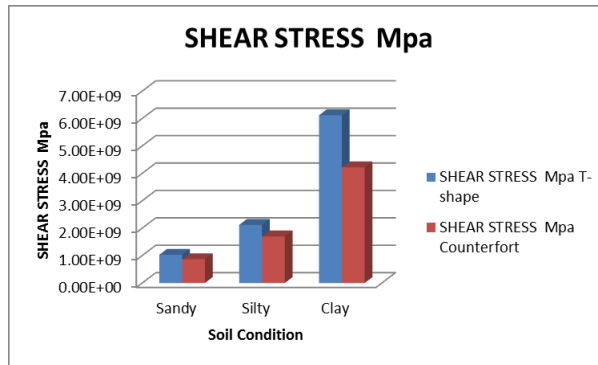

Graph 3 Shear stress

3.4 Normal stress

Table 4 Normal stress

NORMAL STRESS Mpa		
Soil type	T-shape	Counterfort
Sandy	1.70E+10	1.35E+10
Silty	6.10E+10	2.13E+10
Clay	1.05E+11	4.24E+10

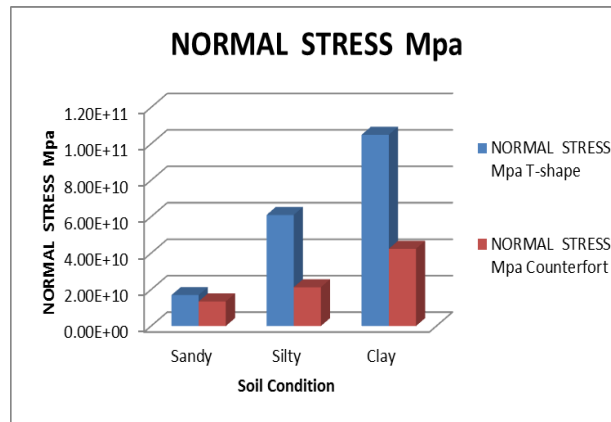

Graph 4 Normal stress

3.5 Shear Strain

Table 5 Shear Strain

SHEAR STRAIN Mpa		
Soil type	T-shape	Counterfort
Sandy	5.15E+08	4.34E+08
Silty	1.06E+09	8.50E+08
Clay	3.06E+09	2.11E+09

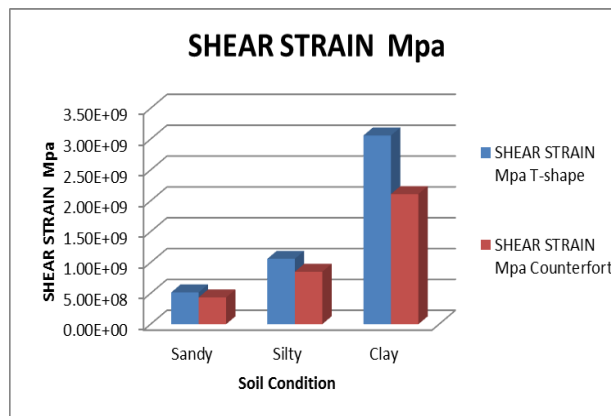

Graph 5 Shear Strain

3.6 Normal Strain

Table 6 Normal Strain

NORMAL STRAIN Mpa		
Soil type	T-shape	Counterfort
Sandy	8.50E+09	6.75E+09
Silty	3.05E+10	1.07E+10
Clay	5.25E+10	2.12E+10

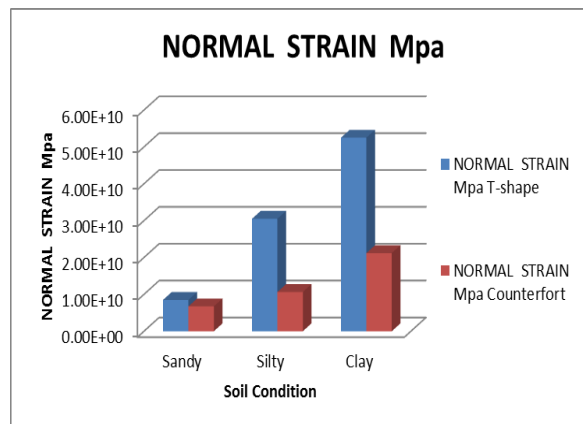

Graph 6 Normal Strain

#### 4. CONCLUSION

It has been observed by parametric study that active earth pressure coefficient are almost identical by different methods, it can be noted from the graphical representations of the results obtained from the application of the different theories.

- It is observed that counter fort retaining wall has more capacity than T- shape retaining walls. From the following results
- The results of the total deformation for the T-shape and counterfort wall for the different soil conditions , as per dam type the Deformation for the counterfort retaining wall is economic than the T shape wall by 20-25% , and as per soil condition Sandy soil have less deformation than silty and clay soil for the both dams
- The results of the Equivalent Stress for the T-shape and counterfort wall for the different soil conditions, as per dam type the Equivalent Stress for the counterfort retaining wall is economic than the T shape wall by 15.20% , and as per soil condition Sandy soil have less Equivalent Stress than silty and clay soil for the both dams
- The results of the Shear stress for the T-shape and counterfort wall for the different soil conditions, as per dam type the Shear stress for the counterfort retaining wall is economic than the T shape wall by 25-30% , and as per soil condition Sandy soil have less Shear stress than silty and clay soil for the both dams
- The results of the Normal stress for the T-shape and counterfort wall for the different soil conditions, as per dam type the Normal stress for the counterfort retaining wall is economic than the T shape wall by 20-25% , and as per soil condition Sandy soil have less Normal stress than silty and clay soil for the both dams
- The results of the Shear Strain for the T-shape and counterfort wall for the different soil conditions, as per dam type the Shear Strain for the counterfort retaining wall is economic than the T shape wall by 15.20%, and as per soil condition Sandy soil have less Shear Strain than silty and clay soil for the both dams
- The results of the Normal Strain for the T-shape and counterfort wall for the different soil conditions, as per dam type the Normal Strain for the counterfort retaining wall is economic than the T shape wall by 10-15% , and as per soil condition Sandy soil have less Normal Strain than silty and clay soil for the both dams

#### REFERENCES

1. cantilever retaining walls using fully dynamic analysis” Elsevier(2017)
2. B. Mendez “Dynamic Soil Pressures on Embedded Retaining Walls: Predictive Capacity Under Varying Loading Frequencies” 6th International Conference on Earthquake Geotechnical Engineering 1-4 November (2015)
3. Siddharth Mehta “Seismic Analysis Of Reinforced Earth Wall: A Review” ISSN 2319 6009 [www.ijscer.com](http://www.ijscer.com) Vol. 4, No. 1, February (2015)
4. MuthucumarasamyYogendrakumar, Richard J. Bathurst, And W. D. Liam Finn, Member, “Dynamic Response Analysis Of Reinforced-Soil Retaining Wall” Asce,(2015)
5. Carlo Rainieri, ArindamDey, Giovanni Fabbrocino, Filippo Santucci de Magistris “Interpretation of the experimentally measured dynamic response of an embedded retaining wall by finite element models” S0263-2241(16)30275-5(2015)
6. S.A.Ingale “Comparison Study of Static and Dynamic Earth Pressure behind the Retaining Wall” Volume 12, Issue 3 Ver. I (May. - Jun. 2015)





7. Mahmoud Yazdani “Extended “Mononobe-Okabe” Method for Seismic Design of Retaining Walls”Journal of Applied Mathematics Volume 2013, Article ID 136132
8. Su Yang “Review of Studies on Retaining Wall’s Behavior on Dynamic / Seismic Condition” ISSN Vol. 3, Issue 6, Nov-Dec (2013)
9. Satoshi Nishimuraa , Hidenori Takahashi , Yoshiyuki Morikawa “Observations of dynamic and non-dynamic interactions between a quay wall and partially stabilised backfill” The Japanese Geotechnical Societyty, Elsevier ( 2012)
10. Murali Krishna, Aff.M.ASCEand G. MadhaviLatha“Modeling the Dynamic Response of Wrap-Faced Reinforced Soil Retaining Walls” American Society of Civil Engineers, 10.1061/(ASCE)GM.1943-5622.0000128 (2012)
11. Scotto di Santolo “Experimental Investigation of Dynamic Behaviour of Cantilever Retaining Walls” USBOA (2012)
12. Mandal “Behavior of Retaining Wall Under Static And Dynamic Passive Earth Pressure”Proceedings of Indian Geotechnical Conference December 15-17, (2011)



**INNO**  **SPACE**  
SJIF Scientific Journal Impact Factor

**Impact Factor:  
7.512**

**ISSN** INTERNATIONAL  
STANDARD  
SERIAL  
NUMBER  
**INDIA**



# INTERNATIONAL JOURNAL OF INNOVATIVE RESEARCH

IN SCIENCE | ENGINEERING | TECHNOLOGY

 **9940 572 462**  **6381 907 438**  **ijirset@gmail.com**



[www.ijirset.com](http://www.ijirset.com)

Scan to save the contact details