



e-ISSN: 2319-8753 | p-ISSN: 2347-6710

IJRSET

International Journal of Innovative Research in
SCIENCE | ENGINEERING | TECHNOLOGY

INTERNATIONAL JOURNAL OF INNOVATIVE RESEARCH

IN SCIENCE | ENGINEERING | TECHNOLOGY

Volume 11, Issue 8, August 2022

ISSN INTERNATIONAL
STANDARD
SERIAL
NUMBER
INDIA

Impact Factor: 8.118

 9940 572 462

 6381 907 438

 ijirset@gmail.com

 www.ijirset.com

An approach of Anti-theft Security System for Vehicles using Biometric

Dr. Praveen Kumar K¹, Manasa L R²

Assistant Professor, B S Channabasappa First Grade College, Davanagere, Karnataka, India¹

Lecturer, B S Channabasappa First Grade College, Davanagere, Karnataka, India²

ABSTRACT: Nowadays, vehicle security is a top priority. The security of today provides little in terms of vehicle safety. Anti-theft security systems are also very expensive, so an effective alternative is required. This paper addresses the issue of vehicle security by using Biometric authentication to start the engine. When the vehicle is accessed using the correct Biometric, the proposed security system sends an SMS to the owner with the address of the accessed location. If the Biometric is incorrect, the system sends an SMS to the owner stating that someone is attempting to access the vehicle at a specific location, and the system immediately disconnects the power supply to the engine ignition system. An Arduino is used to control the GSM and GPS modules in this case.

KEYWORDS: GSM, GPS, security, SMS.

I. INTRODUCTION

The number of vehicle robberies is higher now than at any other time in history. In 2015, one vehicle was stolen every 24 minutes in Delhi, India's capital city, and one vehicle was stolen every 13 minutes in 2016 and 2017. People have already begun to use theft control systems in their vehicles, such as immobilisers, in response to the alarming situation of vehicle theft. However, these are now outdated methods that can be easily hacked, and these antitheft vehicle systems are very expensive. This paper discusses the design and development of a simple antitheft system using an Arduino. The advancement of satellite technology has simplified the identification of vehicle locations. GPS is now used in automobiles, taxis, and police vehicles, among other places. These GPS modules aid in determining the location of vehicles. For communication purposes, the antitheft system under discussion here employs a microcontroller and a GSM module.

II. RELATED WORK

The development of anti-theft control systems began in the early 1990s. The majority of modern systems use GSM and GPS modules to provide the owner with vehicle location information. Kanchana Katta et al. [1] attempted to develop an antitheft system using a GSM and GPS module. When the vehicle is in motion, this system sends the owner the location of the vehicle. The disadvantage is that the owner is only notified after the vehicle has been stolen.

Bhumi Bhatt et al. [2] presented an idea that effectively uses wireless technology for automotive environments by using the GSM modem to provide information to the user on his request. The vehicle is stopped using an 8051 microcontroller. When the thief attempts to steal it, the 8051 is triggered and the message is sent to the owner. When the owner sees the message, he sends a "STOP" message, which causes the vehicle to come to a halt. If the owner does not see the message in time, the vehicle can be driven quite far and will not automatically stop.

[3][4] implements vehicle tracking via GSM and GPS. When a theft occurs, the user of the vehicle is notified. The location of the vehicle can be accessed at any time by the owner via an application that uses GSM and GPS. After the theft, the location of the vehicle can also be obtained here.

G.S. Prashanth Ganesh et al. [5] described a project in which they used only GSM and thus saved money. They used GSM modules and several components in the system, and the owner triggers the microcontroller to start the vehicle. It sends SMS messages to the owner and nearby police stations via the base station. When the system's owner sends a message, the microcontroller receives and processes it. It will send the vehicle's location with a time gap to get the current/present location. The disadvantage here is that the owner must trigger the microcontroller. The majority of the work on antitheft systems involves detecting the location of the vehicle when it is stolen, but it is a good idea to

implement a system to prevent unauthorised access. In this paper, a novel approach to antitheft system is used to prevent unauthorised access to the vehicle via password protection.

The author Wu Aiping proposes using a microcontroller as the core and GPS and GSM interfaced through the serial port in the microcontroller in a 2017 paper [6]. However, the system is a loud sound and light that draws the owner's attention and also shares the location of the car if it moves. The goal is to locate the vehicle and, if possible, to stop it by sending a message. Inside the vehicle, there is a keypad and a display. We can use it to turn on and off the vehicle. We can also track the vehicle using this GSM modem. If the incorrect password is entered, the GPS module tracks the vehicle's location and sends a message to the vehicle's owner.

In their July 2015 paper [7], the authors Kompalli supriya and M.Venkateshwarlu stated that vehicle thefts have increased at an alarming rate around the world in recent years. People have begun to use the theft prevention systems that have been installed in their vehicles. Commercially available anti-theft vehicle systems are prohibitively expensive. Using an inbuilt microcontroller, we make a modest attempt to design and develop a simple, low-cost vehicle theft control scheme. A microcontroller and a mobile phone are used in this scheme for communication.

In a 2011 paper [8], Vinoth Kumar Sadagopan, Upendran Rajendran, and Albert Joe Francis proposed an embedded chip that uses a vibration sensor to sense the key during insertion and sends a text message to the owner's mobile stating that the car is being accessed. Following that, the system in the car prompts the user to enter a unique password. The password is made up of a few characters and numbers. If the user fails to enter the correct password three times, a text message with the vehicle number and GPS location is sent to the police. The message about the unauthorised use is also sent to the owner. Furthermore, the car's fuel injector is deactivated, preventing the user from starting the vehicle in any way. At the same time, a secret lock system is activated, trapping the unauthorised user inside the car, and only the owner, who has the key to the secret lock system, can deactivate the mechanism. This technique aids in moving quickly toward an attempt to steal the. The design is strong and straightforward.

Wan Lili and Chen Tiejun, the authors, proposed an automotive remote alarm system. To achieve Short Message Service (SMS) alarm and dual theft-proof of automobile, GSM module is combined with microcontroller; vibration sensor and speed sensor are used. As mentioned in the 2009 paper [9], the shortcomings of traditional systems, such as low security and a small alarming range, are overcome, and the cost of this system is reduced, so it should have good application prospects.

In the paper 2007 [10], the authors Ms.Padmaja Adgulwar, Prof. Nilesh Chaubey, and Prof. Shyam P Dubey proposed that automobile theft is increasing at an alarming rate around the world. Commercially available anti-theft vehicle systems are prohibitively expensive. We commemorate a modest effort to design and develop a low-cost, simple vehicle theft control scheme that makes use of an integrated microcontroller. The Global System for Mobile Communications (GSM) is the most widely used mobile phone standard in the world. A microcontroller and a mobile phone are used in this system for communication.

The challenges for remote keyless entry designs are achieving low power consumption in both the RKE transmitter and receiver while maintaining good RKE system range and reliability [11,12,13,14].

III. PROPOSED METHEDODOLOGY

To gain access to the vehicle, the proposed system employs a bar code. If the driver's Biometric is correct, a circuit is built up to the engine ignition system. If the bar is twisted, the ignition will not work. If the Biometric is correct, the user will be able to start the vehicle by providing power to the ignition system, and the system will also send the message "Your vehicle has been accessed" along with the location of the vehicle. If the user enters an incorrect bar code, the system will not allow the user to start the vehicle by disconnecting the power supply to the ignition system and will also notify the user that "Someone is attempting to access your vehicle." The location of the vehicle is also sent to the user via SMS in both cases.

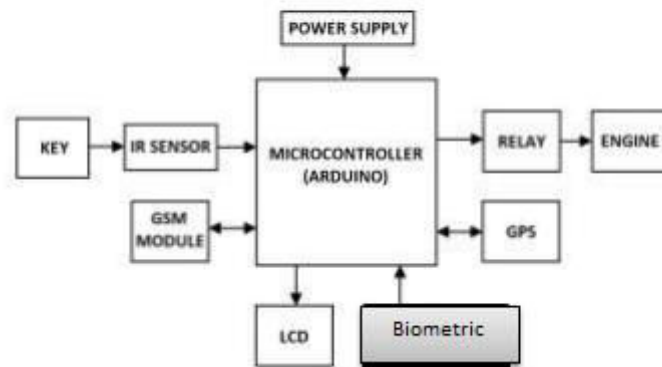

Figure 1: System interfacing

The detailed connection of various modules in the proposed system is shown in Figure 1. A 5V battery is used as the power supply, and the GSM and GPS modules, as well as the keypad and sensor for key detection, are all directly connected to an Arduino controller. A relay connects the engine to the controller. When the system needs to avoid starting the engine, the relay remains open; this occurs when the user fails to provide a bar code. If the user enters the correct bar code, the relay closes and the ignition system is allowed to start the engine.

IV. CONCLUSION

A modest effort has been made to improve the anti-theft security system for vehicles. This work demonstrates extra features such as stopping the vehicle from the registered mobile number when it is stolen and also an emergency calling feature. As a result, this contributes to the vehicle's safety and accessibility.

In today's world, where automobile theft is on the rise, the anti-theft control system is a game changer. Today, GSM is used for the majority of communication and its applications. The use of GSM in an anti-theft control system ensures the required efficiency and security. The GSM also ensures that the system's effectiveness is not limited to local use but can be extended across a broad range. This system includes a one-of-a-kind Biometric setting for unlocking the system.

REFERENCES

- [1]. Kanchana Katta , Ishanu Dutta, Dipankar Gogoi, Biswajit Gayan and Jyotirmay Rabha, "Review on Advanced Vehicle Security System with Theft Control and Accident Notification " ,International Journal For Research In Emerging Science And Technology, Volume-1,Issue-7, December-2014.
- [2]. Bhumi Bhatt, Purvi Kalani, Nayanaben Parmar and Nikunj Shingala, " Smart Vehicle Security System Using GSM & GPS", International Journal Of Engineering And Computer Science ISSN:2319-7242 Volume 4 Issue 6 June 2015, Page No. 12508- 12511V.
- [3]. Pankaj, B.J.S., "Design And Development Of GPS-GSM Based Tracking System With Google map Based Monitoring," in International Journal of Computer Science, Engineering and Applications (IJCSEA) Vol.3, No.3, June 2013.
- [4]. M. Geetha, T. Priyadarshini, B. Sangeetha and S. Sanjana, "Anti-theft and tracking mechanism for vehicles using GSM and GPS," 2017 Third International Conference on Science Technology Engineering & Management (ICONSTEM), Chennai, 2017, pp. 252-255.
- [5]. G. S. Prasanth Ganesh, B. Balaji and T. A. Srinivasa Varadhan, "Anti-theft tracking system for automobiles (AutoGSM)," 2011 IEEE International Conference on Anti-Counterfeiting, Security and Identification, Xiamen, 2011, pp. 17-19.
- [6] Wu Aiping, "The Design of Anti-Theft Device for Vehicle Based on GSM", China, 2017.
- [7] kompalli supriya , M.Venkateshwarlu, "Anti-Theft Control System Design using Embedded System", International Journal of Advanced Technology and Innovative Research, July 2015.



- [8] Vinoth Kumar Sadagopan ; Upendran Rajendran ; Albert Joe Francis, “Anti-theft control system design using embedded system”, IEEE International Conference on Vehicular Electronics and Security, Beijing, July 2010.
- [9] Wan Lili, Chen Tiejun, “Automobile Anti-theft System Design Based on GSM”, International Conference on Advanced Computer Control, Singapore, January 2009.
- [10] Ms.Padmaja Adgulwar, Prof. Nilesh Chaubey, Prof.Shyam P Dubey, “Application on Anti-theft control system” International Journal of research in science and engineering, 2007.
- [11] Narasimhula. M, Naresh Kumar Reddy, B. Subrahmanya Sharma .G (2012) Designing of a Smart Car using ARM7. International Journal of Advances in Engineering and Technology, 2231-1963.
- [12] R.Ramani, S.Valarmathy, Dr. N.SuthanthiraVani tha, S.Selvaraju, M.Thiruppathi, R.Thangam (2013) Vehicle Tracking and Locking System Based on GSM and GPS. I.J. Intelligent Systems and Applications 09, 86-93.
- [13] Sangita N. Gujar, Jagriti R Panchal (2014) Smart Car System Using Sensor GPS and GSM. Intrenational Journal of Electrical and Electronic Engineering & Telecommunications 3, 2319-2518.
- [14] Michal Czubenko, Zdzislaw, Kowalczuk, Andrew Ordys (2015) Cognitive Computation 7, 569-581.



INNO SPACE
SJIF Scientific Journal Impact Factor
Impact Factor: 8.118



ISSN INTERNATIONAL
STANDARD
SERIAL
NUMBER
INDIA



INTERNATIONAL JOURNAL OF INNOVATIVE RESEARCH

IN SCIENCE | ENGINEERING | TECHNOLOGY

 **9940 572 462**  **6381 907 438**  **ijirset@gmail.com**



www.ijirset.com

Scan to save the contact details