



e-ISSN: 2319-8753 | p-ISSN: 2347-6710

IJIRSET

International Journal of Innovative Research in
SCIENCE | ENGINEERING | TECHNOLOGY

INTERNATIONAL JOURNAL OF INNOVATIVE RESEARCH

IN SCIENCE | ENGINEERING | TECHNOLOGY

Volume 11, Issue 12, December 2022

ISSN INTERNATIONAL
STANDARD
SERIAL
NUMBER
INDIA

Impact Factor: 8.118

9940 572 462

6381 907 438

ijirset@gmail.com

www.ijirset.com



Water Cooler cum Water Heater by Using Refrigeration System

Dr. Vilas Pharande¹, Mr. Ghadage Suraj.S.² Mr. Hidayat Rafik Mukadam³

Principal, Arvind Gavali College of Engineering, Maharashtra, India¹

Associate Professor, Department of Mechanical Engineering, Arvind Gavali College of Engineering, Maharashtra, India²

P.G. Student, Department of Mechanical Engineering, Arvind Gavali College of Engineering, Maharashtra, India³

ABSTRACT: The field of mechanical engineering has a theme word called change as its backbone. The new technological advancements and the needs of people have made us think about this project. Our project is maiden venture into the field of water temperature controlling viz. HOT & COLD. The control of temperature of water around us is done by controlling the output water from the water cooler. Our project is a novel idea to control water temperature by the incorporation of cooling system in a single unit. This unit would be an economic utility at all places to provide both hot and cold water to the people. In any Refrigeration system heat energy is lost to the surroundings and it goes as a waste. The work deals with the utilization of the out coming heat energy is to produce hot water in the water cooler. There by we are utilizing the heat lost and also reducing the heat in the condenser to get maximized cold water. The circuit used in this work is same as that of the available water cooler. This concept of utilizing the heat energy evolved to the surrounding can be applied in any 8 refrigerationsystems.

KEYWORDS: Heater, Cooler, Refrigeration.

I. INTRODUCTION

Refrigeration is the process of removing heat from a substance under controlled conditions. Refrigerator is a reversed heat engine or a heat pump which pumps heat from a cold body and delivers it to a hot body. The substance which works in a heat pump to extract heat from a cold body and to deliver it to a hot body is called refrigerant. Refrigeration is accomplished by various methods such as the vapour compression system, absorption system, steam jet refrigeration cycle. The vapour compression system of refrigeration is widely used. In the work also the vapour compression system is used.

A refrigerator (colloquially fridge) consists of a thermally insulated compartment and a heat pump (mechanical, electronic or chemical) that transfers heat from the inside of the fridge to its external environment so that the inside of the fridge is cooled to a temperature below the room temperature. Refrigeration is an essential food storage technique in developed countries. The lower temperature lowers the reproduction rate of bacteria, so the refrigerator reduces the rate of spoilage. A refrigerator maintains a temperature a few degrees above the freezing point of water. Optimum temperature range for perishable food storage is 3 to 5 °C (37 to 41 °F).[1] A similar device that maintains a temperature below the freezing point of water is called a freezer. The refrigerator replaced the icebox, which had been a common household appliance for almost a century and a half.

The first cooling systems for food involved ice. Artificial refrigeration began in the mid-1750s, and developed in the early 1800s. In 1834, the first working vapor-compression refrigeration system was built. The first commercial ice-making machine was invented in 1854. In 1913, refrigerators for home use were invented. In 1923 Frigidaire introduced the first self-contained unit. The introduction of Freon in the 1920s expanded the refrigerator market during the 1930s. Home freezers as separate compartments (larger than necessary just for ice cubes) were introduced in 1940. Frozen foods, previously a luxury item, became commonplace.

Freezer units are used in households and in industry and commerce. Commercial refrigerator and freezer units were in use for almost 40 years prior to the common home models. The freezer-on-top-and-refrigerator-on-bottom style had been the basic style since the 1940s, until modern refrigerators broke the trend. A vapor compression cycle is used in most household refrigerators, refrigerator-freezers and freezers. Newer refrigerators may include automatic defrosting, chilled water, and ice from a dispenser in the door.



Domestic refrigerators and freezers for food storage are made in a range of sizes. Among the smallest are Peltier-type refrigerators designed to chill beverages. A large domestic refrigerator stands as tall as a person and may be about 1 m wide with a capacity of 600 L. Refrigerators and freezers may be free-standing, or built into a kitchen. The refrigerator allows the modern household to keep food fresh for longer than before. Freezers allow people to buy food in bulk and eat it at leisure, and bulk purchases save money.

II. LITERATURE SURVEY

[1] In 1758, Ben Franklin and a colleague in England, chemist John b Hadley, conducted an experiment on the cooling properties of evaporation. By using a bellows to evaporate highly volatile liquids like alcohol and ether, they were able to drop the temperature to 7°F, building up a thick layer of ice on their mercury thermometer—while the ambient temperature was 64°F (Energy Solution, 2012)

[2] In 1820, another of history greatest scientists, the British inventor Michael Faraday, showed that by mechanically compressing ammonia to liquefy (condense) It and then allowing the ammonia to expand and evaporate, he could cool air.

[3] in 1842, a Florida physician, John Gorrie, wanted to keep patients cool, was able to use this principal to make ice in an Apalachicola hospital.

[4] in 1851 Gorrie patented his system and hoped to commercialize it to cool buildings, but his FINANCIAL backer died and with it, Gorrie’s Path to success. Air conditioning would not reappear for 50 years

[5] In 1902, Willis Carrier of Syracuse, New York perfected a system for dehumidifying a commercial printing plant. The goal was to stabilize the paper, but the invention also kept the plant’s Temperature more comfortable and the workers more productive. He formed The Carrier Air Conditioning Company of America to produce these systems, eventually extending beyond commercial buildings to homes .With 32,000 employees in 170 countries, Carrier Corporation(now a subsidiary of United Technologies Corporation) is today the world leader in high technology heating,air conditioning, and refrigeration system

III. WORKING

A simple vapor compression refrigeration system consists of the following equipment’s: i) Compressor ii) Condenser iii) Expansion valve iv) Evaporator

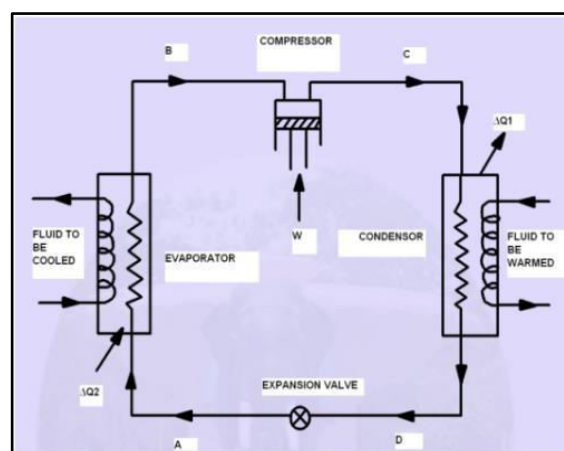

The schematic diagram of the arrangement is as shown in Figure the low temperature, low pressure vapour at state B is compressed by a compressor to high temperature and pressure vapour at state C. This vapour is condensed into high pressure vapour at state D in the condenser and then passes through the expansion valve. Here, the vapour is throttled

down to a low pressure liquid and passed on to an evaporator, where it absorbs heat from the surroundings from the circulating fluid (being refrigerated) and vaporizes into low pressure vapor at state B. The cycle then repeats. The exchange of energy is as follows:

The refrigerant being sucked to the compressor through the suction line. Afterward the refrigerant compressed into the compressor and the compressed refrigerant being discharged to the condenser unit through the discharge line. When the high pressure refrigerant vapour enters the condenser heat flows from condenser to cooling medium thus allowing vaporized refrigerant to return to liquid state. After condenser the liquid refrigerant is stored in the liquid receiver until needed. From the receiver it passes through an expansion valve where the pressure is reduced sufficiently to allow the vaporization of liquid at a low temperature of about – 10 degree centigrade. The low pressure refrigerant vapour after expansion in the expansion valve enters the evaporator on refrigerated space where a considerable amount of heat is absorbed by it and refrigeration is furnished.

III. EXPERIMENTAL SETUP



COMPRESSION: The refrigerant being sucked to the compressor through the suction line. Afterward the refrigerant compressed into the compressor and the compressed refrigerant being discharged to the condenser unit through the discharge line.

CONDENSATION: When the high pressure refrigerant vapour enters the condenser heat flows from condenser to cooling medium thus allowing vaporized refrigerant to return to liquid state.

EXPANSION: After condenser the liquid refrigerant is stored in the liquid receiver until needed. From the receiver it passes through an expansion valve where the pressure is reduced sufficiently to allow the vaporization of liquid at a low temperature of about – 10 degree centigrade.

VAPORIZATION: The low pressure refrigerant vapour after expansion in the expansion valve enters the evaporator on refrigerated space where a considerable amount of heat is absorbed by it and refrigeration is furnished.

So during condensation process the refrigerant will give its heat to water which is to be heated and thus we get hot water and similarly during vaporization process cooled refrigerant will absorb the heat from water and thereby getting cooled water.



V. RESULT AND CALCULATIONS

Tabulation

S. no	Time (t) in min	Evaporator temperature in (⁰ c)		Condenser temperature in (⁰ c)		Compressor pressure in (psi)		Cold water temperature (⁰ c)	Hot water temperature (⁰ c)
		Inlet (Tci)	Outlet (Tco)	Inlet (Thi)	Outlet (Tho)	Inlet (p1)	Outlet (p2)		
1	0	29	29	32	29	1.7	12	31	31
2	30	31	28	35	31	2.1	13	28	33
3	60	33	27	38	33	2.5	14	24	36
4	90	34	27	50	34	2.7	14	24	42

The graphs are drawn according to the respective values in the table for cold chamber, hot chamber, pressure and comparison of C.O.P of air and water.

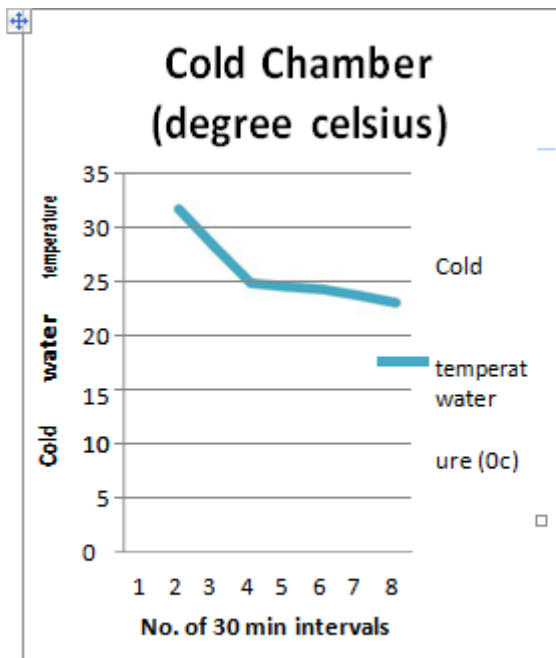

Figure Cold Chamber graph

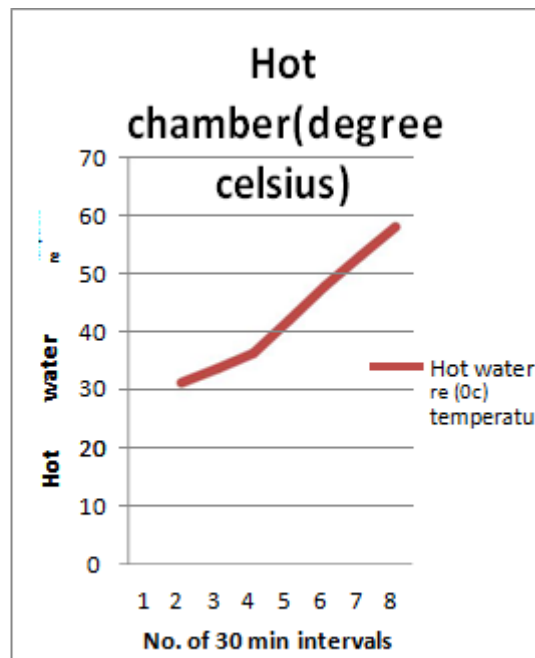

Figure Hot Chamber graph

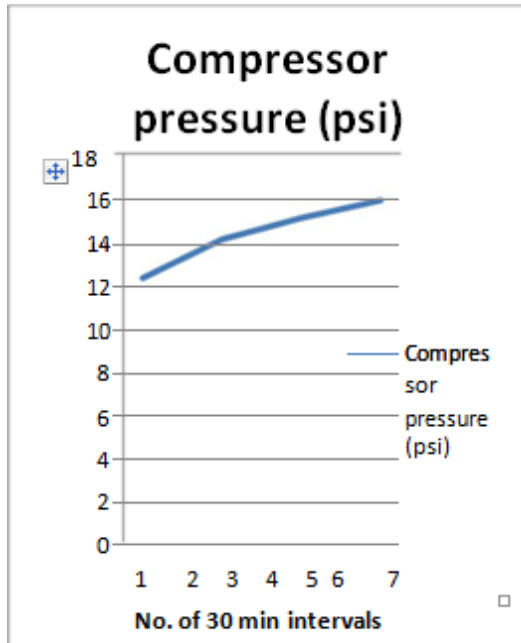

Figure Compressor pressure graph

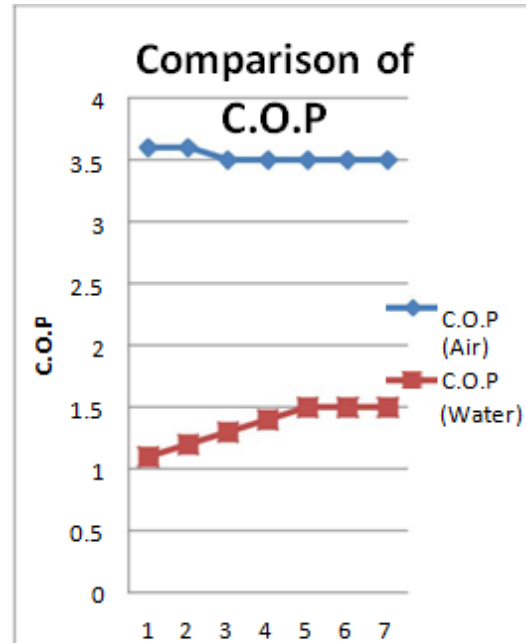

Figure COP graph

VI. CONCLUSION

The main objective of this product is to make the project having two rival properties of getting cold water and hot water. This system can be used continuously. By using our system there is no need of going for a separate water heater and water cooler. As both purposes are served by a single system, the cost is also lowered to a considerable level.

REFERENCES

[1] P Domanski, (ed.), 1997. Refrigerants for the 21st Century, ASHRAE
 [2] J R Sand, S.K. Fischer and V.D. Baxter, 1997. Energy and global warming impacts of HFC refrigerants and emerging technologies, sponsored by the Alternative Fluorocarbons Environmental Acceptability Study and the U. S. Department of Energy, Oak Ridge.
 [3] Schaefer, L.A. and S.V. Shelton, 1998. —Heat Exchanger Mean Temperature Differences for Refrigerant Mixtures, Proceedings of the ASME Advanced Energy Systems Division, vol. 38, H.Metghalchi et al., pages, pp: 383-389.
 [4] Kim, S.G., M.S. Kim and S.T. Ro, 2002. —Experimental investigation of the performance of R22, R407C and R410A in several capillary tubes for air conditioners. International Journal of Refrigeration, 25: 521-531.
 [5] Akintunde, M.A., 2008. Ph.D. Effect of Coiled Capillary Tube Pitch on Vapor Compression Refrigeration System Performance. The Pacific Journal of Science and Technology, 9(2): 284-294.
 [6] Raut, A.S. and U.S. Wankhede, 2011. Selection of the Capillary Tubes for Retrofitting in Refrigeration Appliances. International Journal of Engineering Science and Technology ISSN/EISSN: 09755462 Year.



INNO SPACE
SJIF Scientific Journal Impact Factor
Impact Factor: 8.118



ISSN INTERNATIONAL
STANDARD
SERIAL
NUMBER
INDIA



INTERNATIONAL JOURNAL OF INNOVATIVE RESEARCH

IN SCIENCE | ENGINEERING | TECHNOLOGY

 **9940 572 462**  **6381 907 438**  **ijirset@gmail.com**



www.ijirset.com

Scan to save the contact details