



e-ISSN: 2319-8753 | p-ISSN: 2347-6710

IJIRSET

International Journal of Innovative Research in
SCIENCE | ENGINEERING | TECHNOLOGY

INTERNATIONAL JOURNAL OF INNOVATIVE RESEARCH

IN SCIENCE | ENGINEERING | TECHNOLOGY

Volume 11, Issue 1, January 2022

ISSN INTERNATIONAL
STANDARD
SERIAL
NUMBER
INDIA

Impact Factor: 7.569

9940 572 462

6381 907 438

ijirset@gmail.com

www.ijirset.com

Gesture Controlled Robot Using Arduino

T. Venkataramana¹, Ch. Sunil kumar², M. Siddu², B.Sanjay²

Assistant Professor, Department of Mechanical Engineering, Guru Nanak Institute of Technology, Khanapur,
Telangana, India¹

U.G. Student, Department of Mechanical Engineering, Guru Nanak Institute of Technology, Khanapur,
Telangana, India²

ABSTRACT: The end of the design is to design and develop the gesture- controlled robot. The robot is designed by enforcing gesture control and programmed using Arduino software. Gestures can be tracked using accelerometers an inbuilt accelerator and a Bluetooth module which controls the kinetics of a prototype robot. Since ultramodern Smartphone are equipped with an in- erected accelerometer, gesture control using Smartphone can be easy to apply, cheap to give and the affair will be more intuitive.

The gesture recognition is to minimize the distance between the physical world and the digital world. The way humans interact among themselves could be enforced in communication with the digital world by interpreting gestures via fine algorithm. Multitudinous ways and algorithms have been proposed and enforced to achieve the thing of gesture recognition and its use in communicating with the digital world.

KEYWORDS: Arduino microcontroller, Accelerometer, Gesture recognition, Bluetooth Module, Motor driver, Smartphone

I. INTRODUCTION

Humans interact in the physical world by the means of the five senses. Still, gestures have been an important means of communication in the physical world from ancient times, indeed before the invention of any language. In this period of machines taking control of every complex workshop, relations with machines have come more important than ever.

A gesture is a form of communication in anon-verbal manner by using visible body movements or conduct conveying dispatches. There are several ways to capture a mortal gesture that a machine would be suitable to understand. The gesture can be captured using a camera, or a data glove. Gestures can also be captured via Bluetooth or infrared swells, Acoustic, Tactile, optic or stir technological means.

There are two types of gestures used in gesture recognition Online gestures and Offline gestures. In Online gestures, direct manipulations like gyration and scaling are done. In Offline gestures, the processing is done only after the stoner interacts with the object. Gesture technologies are applied in several fields like in Stoked Reality, socially assistive Robots, recognition of sign languages, emotion discovery from facial expressions, Virtual mouse or keyboard, recognition of sign languages, remote control, etc.

II. LITERATURE REVIEW

Before the morning of the process of designing of robotic arm it's necessary to survey the request about thepre-existing trends in order to identify with the ultramodern technology so that the product does n't get obsolete. There are number of trending robots that are inversely fascinating enough. Hence, it centrists between the idea and the prototype.

1. Sadam (2015) proposed the accelerometer grounded gesture controlled robot by using arduino uno. In this design he used hand stir to drive the robot. For this purpose he introduced accelerometer which works on acceleration in place of any other system like buttons or joystick. (1)

2. Jitin sanal (2018) Gesture Controlled Robot using jeer pie for Wireless Surveillance. In this series, he make a robot which can travel through rough terrain and can be controlled using hand gestures. To control the robot, he used gloves that will have an accelerometer and a flex detector to control the status and the direction it should move. (2)

3. Engr fahad (2019) In this design he proposed the Flex detector, it'll be used as the accelerator while the joystick will be used for controlling the forward, rear, left and right movements. The Motors speed can be controlled in real-time as we near and open the hand. The robot control system can be actuated andde-activated using the Erected-in Joystick push Button. The use of Flex Sensor makes this design Hand gesture- controlled Robot. (3)



4. Hai prasaath k (2021) He was bandied how remote controls with switches or buttons used for controlling wireless robots have a disadvantage in controlling the robot due to response time factor of the mortal running it. As a result to the problem, he designed that will be controlled by the joystick. A joystick isn't a new input device but it provides better control over the subject. It's easier to use and handle by a mortal driver. (4)

5. Muhammad Imran Shahzad and Saqib Mehmood (2010) proposed Control of Articulated Robot Arm by Eye Tracking. They developed two different interfaces to control the articulated robot manually. The first of these interfaces is controlled by mouse and the second is controlled by eye shadowing. They enforced this design to grease the people with motor disabilities by using their eye as an input rather of a mouse. Eye aspect tracking fashion is used to shoot commands to perform different tasks. (5)

6. Muhammad Usman (2020) He developed a Gesture identification to replace the approach of the conventional controlling medium of robots similar as joysticks, keypads by hand gesture grounded controlling. This robotic arm has 3 degree-of- freedoms (DOF) with cutlet gripper. It's controlled by different hand gestures movements in front of a camera. Machine vision and image processing ways are used for hand gesture recognition. The algorithm and its perpetration for gesture recognition are presented and the results of different way of the proposed system are explained. (6)

III. METHODOLOGY

We had researched and gathered all the equipment and parts which are required for making a prototype The methodology we followed as follows:

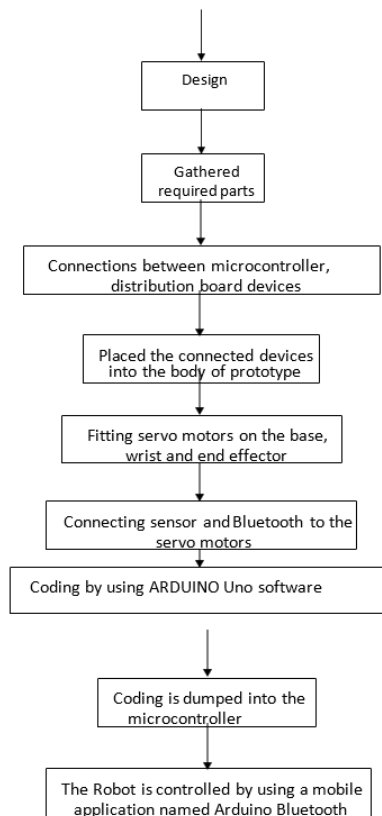

A . DESIGN :In the Catia software the model of physical prototype (chasis) to be fabricated is designed according to the required dimensions.

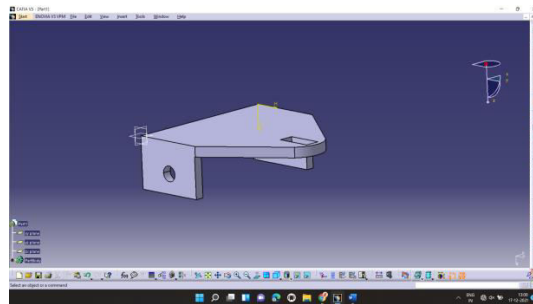

Figure 1- chassis designed in catia

B . GATHERED REQUIRED PARTS :All the required electronic and mechanical components are gathered to our required project. They are DC motors (2) , stepper motor , Arduino uno microcontroller , motor driver (L298N) , Bluetooth (HC-05) , Battery (lithium ion battery) , wheels (4).

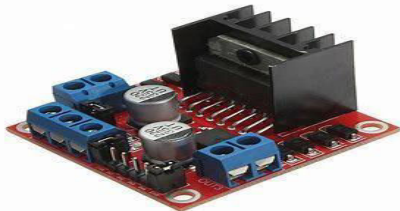

Figure 3 - Motor driver



Figure 2 - arduino board

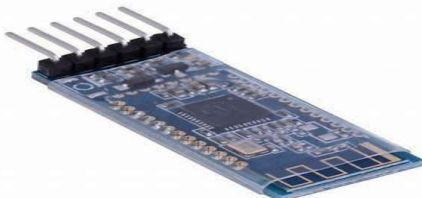

Figure 4 - bluetooth module (HC-05)

C . CONNECTIONS OF ELECTRONIC COMPONENTS : Arduino board are is connected to the required devices like power distributor , motor driver and bluetooth module. According to the given input pin number we are connected devices with jumper wires.

Stepper motor and DC motors are connected partially to the motor drivers using jumper wires.

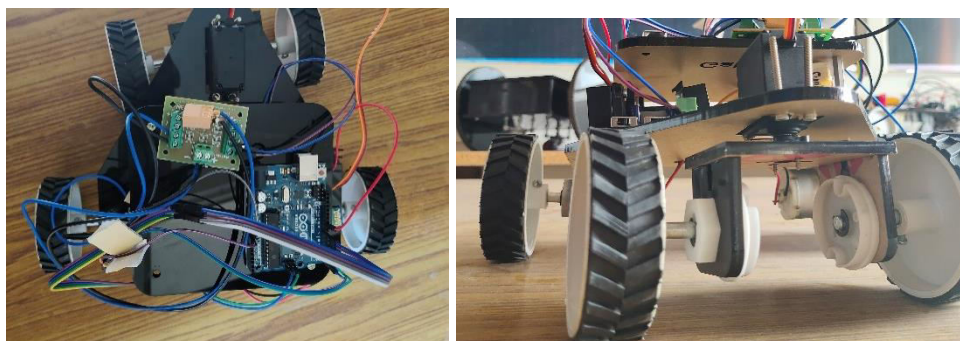

Figure 5 - assembled prototype

D . FITTING MECHANICAL COMPONENTS : The wheels are attached to the chassis using side supports. Transmission of stepper motor motion to the rear wheels using an attachment is fixed using nuts and bolts.

E . CODING AND DUMPING : The required gesture movement is recognised and turned to physical movements of robot are done by using programming in Arduino ide and the programme is compiled to check errors. The error free programme is simulated using proteus for detailed overview of project. Programmed file is saved and dumped into the microcontroller.

F . CONTROLLING OF ROBOT : We had used smart phone instead of attachable accelerometer. By installing the application MY ROBOT LAB robot is connected to Bluetooth module and controlled.

IV. RESULTS

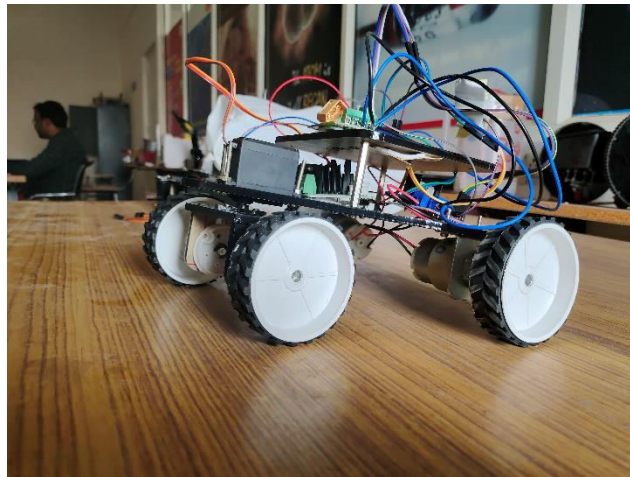

Figure 6 (a)

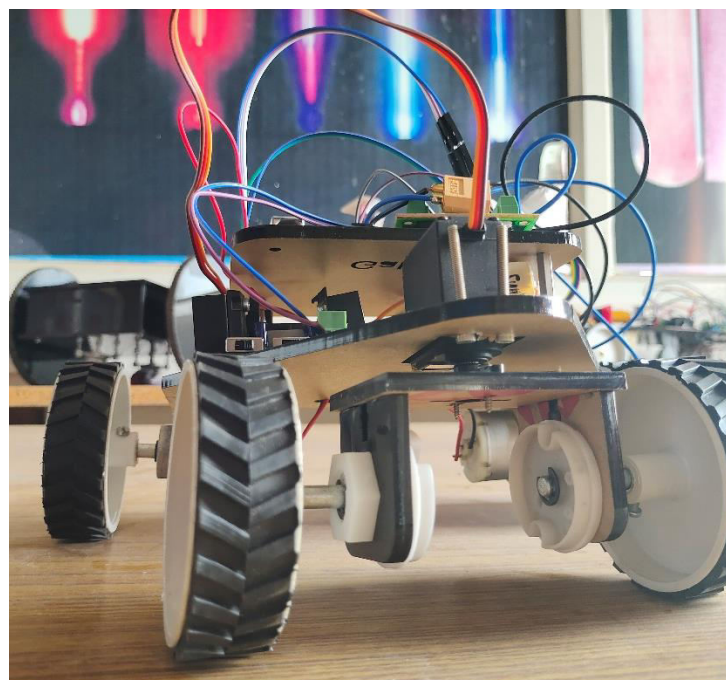

Figure 6 (b)

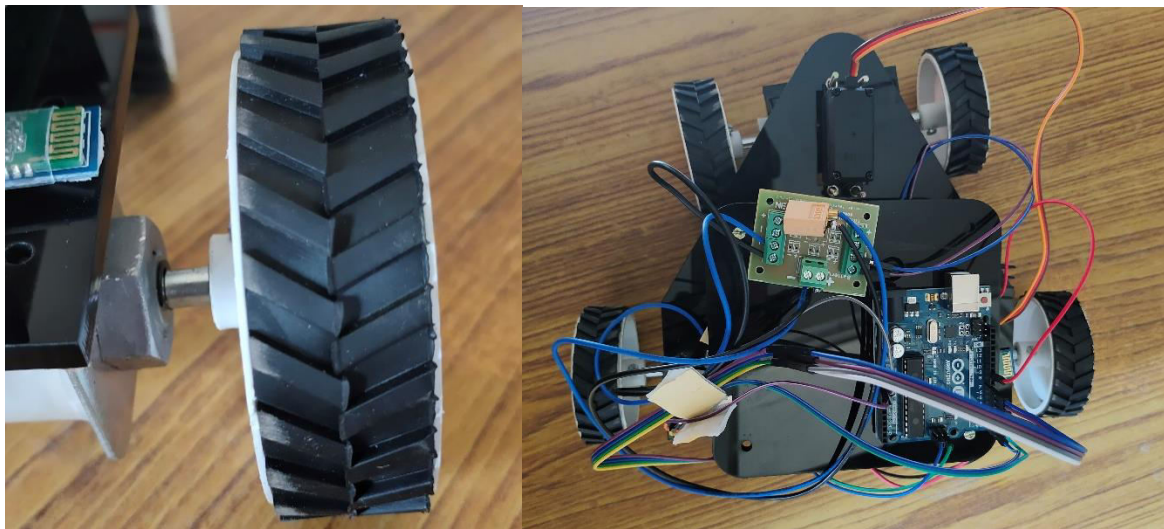

Figure 6 (c) , (d)

Figure 6 (a,b,c,d) - final prototype

The above figures are final assembled prototype of Gesture-controlled robot, the chassis is designed using CATIA, microcontroller programming is programmed in Arduino ide and dumped into the microcontroller.

V. CONCLUSION

We have implemented the traditional steering mechanism to the gesture controllable robot. The coded program is converted to mechanical motion using Arduino uno microcontroller. The main aim of the project is to help the physically handicapped people. The final movement of the robot can be concluded as follows: At the beginning the robot was in a stop mode. As the mobile moved from bottom to top, the robot moved in the backward direction. As the mobile moved from top to bottom, the robot moved in the forward direction. As the mobile was shown as an acute angle towards the left, the robot moved towards the left direction. As the mobile was shown as an acute angle towards the right, the robot moved towards the right direction.

REFERENCES

- [1] Nitin and Naresh, “ Gesture Controlled Robot PPT”, URL Available (<http://seminarprojects.com/s/hand-gesturecontrolled-robotppt>)
- [2] Naveet Kumar, Neeraj Purohit, “Gesture Controlled Tank Toy Stoner Companion” URL Available (<http://www.slideshare.net/neeraj18290/wireless-gesturecontrolled-tank-toy-transmitter>) Penetrated 13 October 2013.
- [3] Jochen Triesch and Christoph Von Der Malsburg “ Robotic Gesture Recognition (1997)” URL Available (<http://citeseerx.ist.psu.edu/viewdoc/summary?doi=10.1.1.37.5427>) Penetrated 15 October 2013.
- [4] “ Real- Time Robotic Hand Control Using Hand Gestures” by Jagdish Lal Raheja, Radhey Shyam,G. Arun Rajsekhar andP. Bhanu Prasad.
- [5] Bhosale PrasadS., Bunage YogeshB. and Shinde SwapnilV. “ Hand Gesture Controlled Robot” URL Available
- [6] (http://www.engineersgarage.com/contribution/accelero_cadence_ grounded_ hand_ gesture_ controlled_robot) Penetrated 3 November, 2013.
- [7] (http://www.robotplatform.com/howto/L293/motor_driver_1.html) Penetrated 5 November, 2013.



**Impact Factor:
7.569**



INTERNATIONAL JOURNAL OF INNOVATIVE RESEARCH

IN SCIENCE | ENGINEERING | TECHNOLOGY

 9940 572 462  6381 907 438  ijirset@gmail.com



www.ijirset.com

Scan to save the contact details