



e-ISSN: 2319-8753 | p-ISSN: 2347-6710

IJIRSET

International Journal of Innovative Research in
SCIENCE | ENGINEERING | TECHNOLOGY

INTERNATIONAL JOURNAL OF INNOVATIVE RESEARCH

IN SCIENCE | ENGINEERING | TECHNOLOGY

Volume 11, Issue 1, January 2022

ISSN INTERNATIONAL
STANDARD
SERIAL
NUMBER
INDIA

Impact Factor: 7.569

9940 572 462

6381 907 438

ijirset@gmail.com

www.ijirset.com



Channel Equalization using Neural Network based Supervised Learning

Abubeker Ibrahim¹, Neeraj Sharma², Sandeep Kumar Jain³

P.G. Student, Department of ECE, Vivekananda Global University, Jaipur, India¹

Associate Professor, Department of ECE, Vivekananda Global University, Jaipur India^{2,3}

ABSTRACT: Equalization is a process of signal conditioning in which circuitry is used at the receiver's end to mitigate non-linear effects of the communication channel. This paper basically focuses on how to incorporate nonlinearity phenomena in channel equalizers. Literature review of various artificial neural network (ANN) based equalizers such as functional-linked ANN, radial basis function, multilayer perceptron, conventional neural network, and its variants are thoroughly analyzed. The convergence and complexity of various algorithms were compared.

KEYWORDS: Machine learning, Inter-symbol interference, Multilayer Perceptron (MLP), Convolutional Neural Network(CNN), Functional linked Artificial Neural Network

I. INTRODUCTION

In any digital communications system, channel equalization must be used to mitigate ISI.[1] There have been many equalizers since 1965 and they have been modified and implemented to deal with ISI and other distortions to get a reliable communication path. Adaptive equalizers using FIR filters were the first to deal with the disturbance of signals. They have been used to check the time-varying changes of channels. Adaptive channel equalization usually consists of the training and tracking phase. During the training time, a transmitter passes a training sequence to a receiver to work on a proper setting for the equalizer in the receiver. Immediately after the training, user data can be sent. In this stage, the equalizer may predict the channel statistics and utilize the data to upgrade the coefficients, to make an adaptive filter to be familiar with time-varying communication scenarios. Depending on the distortion and the output performance channel equalization are divided into linear and non-linear equalizers [2]. Machine learning-based channel equalizers are being used to deal with computational complexity. The motivation behind this trend was that the traditional equalization using adaptive filters was having a huge computational cost. ML-based equalizers can be trained to perform much better in a span of a few seconds. It was the steppingstone to suppress ISI. MLP, Radial basis function (RBF) Convolution neural network [3] Functional link neural network [4] Extreme learning machine, Support vector machine[5] are commonly used. In ML-based channel equalizers, a class is determined by an output of symbol and a basic nonlinear boundary placed in higher-dimensional space. Thus, the computational complexity of ML-based equalization is known by the quantity symbols and the dimension of constructed space.

II. METHODOLOGY

Multilayer perceptron-based channel equalization

MLP is a feedforward NN that is constructed in three layers. The input, hidden, and the output layer. As shown in the figure. 1 the hidden layer is situated between the input layer and output layers. It is where training repeatedly occurs and acts as the computational block of the system. The input layer receives a signal and feeds it to the hidden layer. The output layer is where data is presented. The output layer does some tasks like classification and prediction. The backpropagation algorithm was the main training algorithm for MLP. But now there is a new and better method of training MLP to be efficient and perform well in bit error rate (BER). Gradient descent algorithm is used to train MLP because of its optimal performance. The principle behind the GDA is to upgrade the decision variable by using the derivative of object function, where the cost function's value will decline.[6]

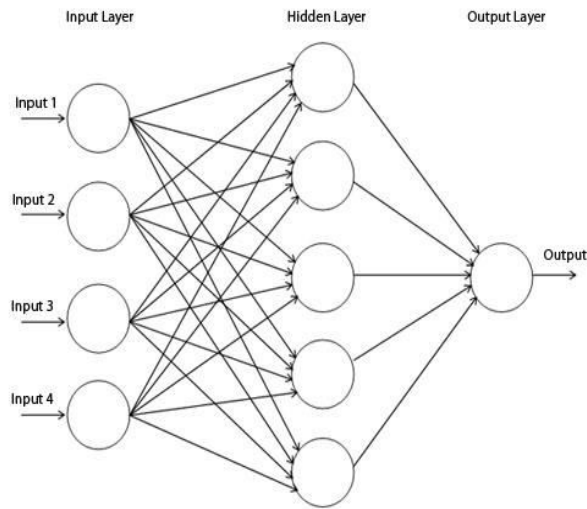

Fig 1. MLP Structure

Functional link ANN-based equalizers

FLANN does not have many layers, it has less computational complexity. and can be applied using hardware [7]. In FLANN, to increase the dimension of a pattern and to boost the first input pattern the function functional expansion is implemented. Moreover, the input pattern’s functional expansion could be applied with the aid of common functions like Chebyshev, Gaussian, trigonometric, and Legendre P. [8]. Compared with the MLP, the FLANN does not have any hidden layers. Because of its simple nature, FLANN attracts many research domains including channel equalization and estimation. Here, FLANN-based equalizers achieved functional expansion by using orthogonal trigonometric functions. Based on the same principle a modified form of FLANN was introduced, Reduced feedback FLANN. [9]. In addition to utilizing the output of a channel as the input signals to the network, the RDF-FLANN-based equalizer feeds back the output signals to the input layer of a selected network. The Chebyshev NN (CHNN) was introduced for channel equalizations, mainly by using common types of QAM signals to simplify the overall mechanism [10]. Many research works have emphasized that by expanding the input space, Chebyshev NN can show excellent competition for the static function than trigonometric Polynomials. Even though, FLANN-based equalizers have less performancwhen a higher-order complexity increases. The BER also decreases

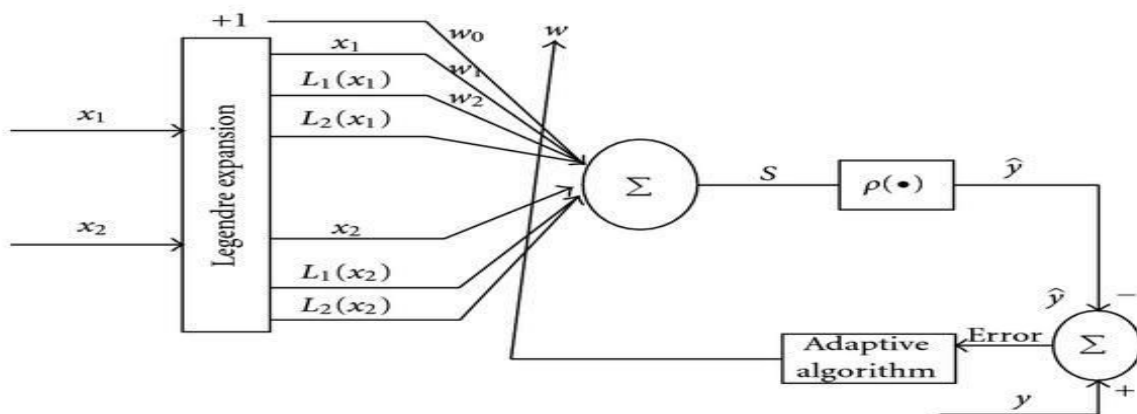

Fig 2. FLANN Structure

Radial basis function-based NN

In a radial basis function-based channel equalizer, incoming signals are categorized on the merits of their center vector. The radial basis function neural network structure is constructed based on the Bayesian principle. Training of the RBF consists of adding the parameters for the centers and expanding the linear weights. The Expanding factor and the weights can be done sequentially and the network grants a nonlinear mapping, keeping its linearity in parameter design at the output. The recent technique implemented to train the RBF network in a supervised manner is by estimating the centers with the help of clustering algorithms like κ -means clustering. The stochastic-gradient training algorithm works perfectly with complex-valued RBF. Later on, a fuzzy neuron system was created based on fuzzy logic methodology [11]. It made the training scheme of each block of RBF easy and fast.

Convolution NN-based equalizers

A convolutional NN is always associated with the research scheme of image identification and processing but it also shows promising results in the area of channel equalization. It has some similarities with deep learning networks because of block-based structures in different stages. It does not use layers that are fully connected like that of MLP. Convolutional operations, activation operations, and downsampling are carried out in the pooling stage. CNN is preferred to be used as equalizers to compensate the distorted signal because of the strong features-extraction ability CNN used to deal with a nonlinear model, although ISI is found between simultaneous bits [12] of the sequence which has been sent, the effect of nonlinear distortion is separate for each bit.

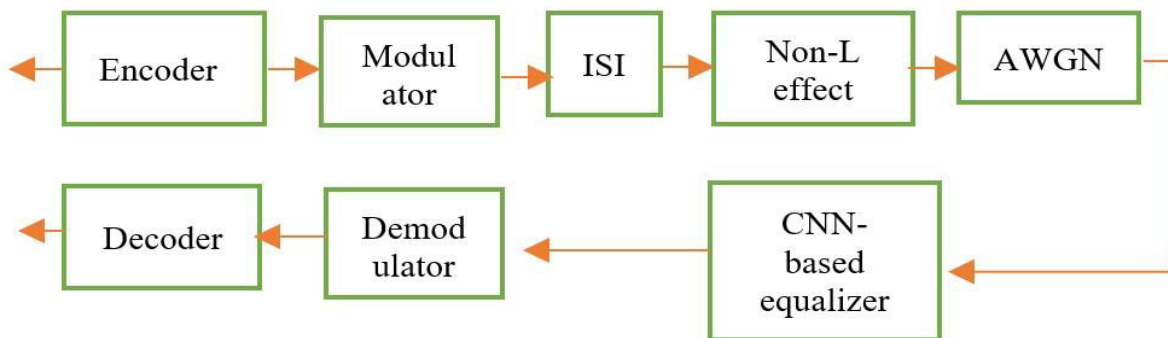

Fig.3 Block diagram of System model for CNN equalization

Extreme learning and Support vector machine-based equalizers

Extreme learning machine (ELMs) was chosen because of their unique ability to minimize training error and norms of an output weight with an accurate learning mechanism. Where less training error brings a decline in the value of weights, this type of feedforward NN can easily gain the expected performance with the same hidden layer parameter. Due to this reason, it was chosen for visualization and image processing research. [13]. To increase the performance of a channel with the real-time transmission, researchers used ELM to test distortion-free data transmission and the result was better with less cost and training time. [14] to compute fast in short data packet transmission QAM is mainly used. Machine-learning-based equalization can deal with ISI if they are trained using kernel-based SVM. If there is nonlinearity and complex situation. SVM was chosen for channel equalization because of its ability to deal with computational complexity uniquely.

III. EXPERIMENTAL RESULTS

Channel equalization using ML technique has shown promising results in mitigating Inter-symbol interference and co-channel interference. The advantage of training the models multiple times grants the overall mechanism a quick response toward compensating the distorted signal. We have trained five prominent neural networks with the same iteration interval and SVM shows an excellent result as shown in the table. We have noted the importance of ML in wireless communication to avoid distorted channel pass uncorrected.



Table 1

NN	Total time(s)	iteration	Time single Iteration (s)
SVM	5.231	1,000,000	5.2315×10^{-6}
LSTM	102.957	1,000,000	1.029576×10^{-4}
RBF	12.2729	1,000,000	1.2273×10^{-5}
FLANN	36.3450	1,000,000	3.6345×10^{-5}
MLP	13.0859	1,000,000	1.3086×10^{-5}

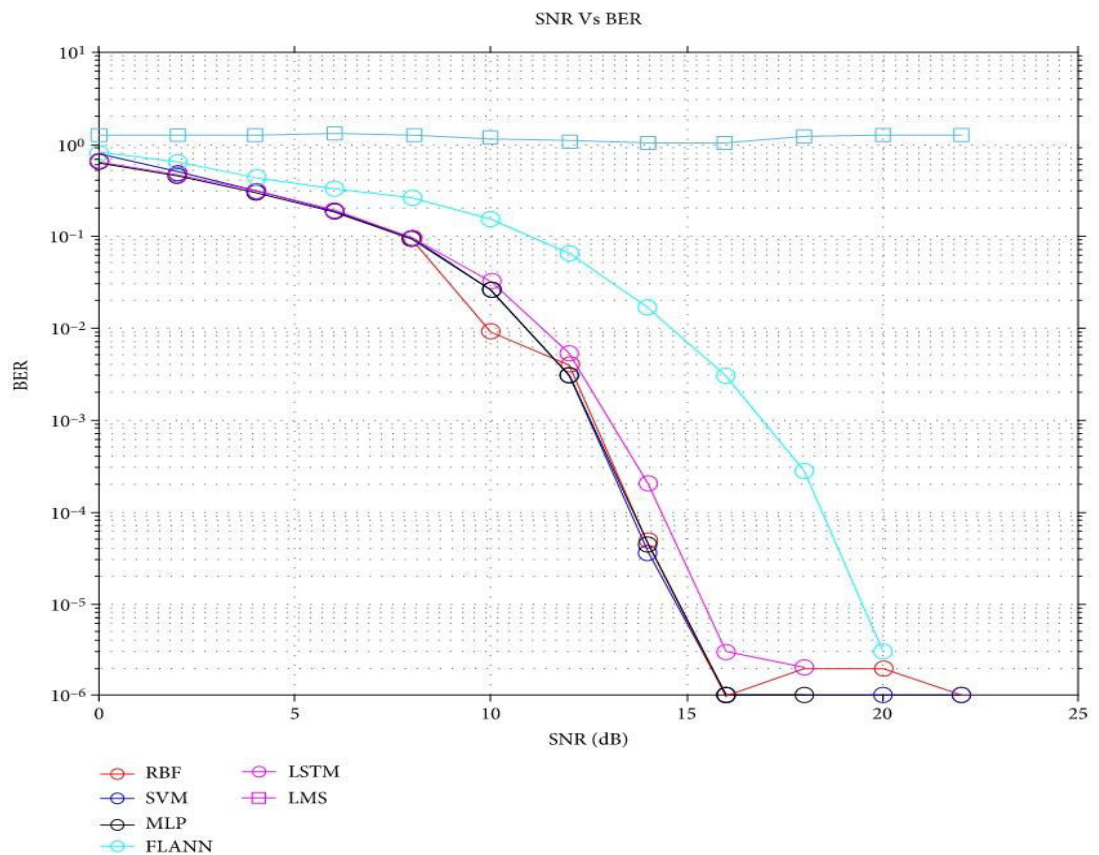

Fig 3, BER performance of neural networks



IV. CONCLUSION

The main goal of the above machine learning technique is to combat inter-symbol interference. As we have discussed above MLP is better than the traditional adaptive filter-based equalizers because of its advanced structure which allows sophisticated training in the hidden layers. But the single layer FLANN is faster than MLP because of its less computational complexity. Even though when the functions expand, FLANN behaves weaker. RBF with a fuzzy NN has been widely used in cellular communication because of the capability to deal with distortion effectively. Conventional neural networks are used recently for both channel detection and equalization. CNN has a unique design that works in both online deployment and offline training. CNN has three main stages. Convolution stage, detection of nonlinearity stage, and polling stage. Extreme learning machine has a great accuracy rate, and it has been widely used to mitigate ISI. Support vector machine also shows promising performance as it is shown. Sometimes with less training cost. In general, ML-based equalizers perform effectively with different algorithms. Deep learning is also has been used to deal with complex situations.

REFERENCES

- [1] T.S. Rappaport. Wireless Communications: Principle and Practice. Prentice-Hall, 2nd Edition, 2002.
- [2] M. Chiu and C. Chao. Analysis of LMS-adaptive MLSE equalization on multipath fading channels. *IEEE Transactions on Communications*, 44(12): 1684–1692, 1996
- [3] Patra, R.N. Pal, R. Baliarsingh, and G. Panda. Nonlinear channel equalization for QAM signal constellation using artificial neural networks. *IEEE Transactions on Systems, Man and Cybernetics, Part B (Cybernetics)*, 29(2): 262–271, 1999.
- [4] Perez-Cruz, A. Navia-Vazquez, P.L. Alarcon-Diana, and A. Artes-Rodriguez. SVC-based equalizer for burst TDMA transmissions. *Signal Processing*, 81(8): 1681–1693, 2001.
- [5] Sebald and J.A. Bucklew. Support vector machine techniques for nonlinear equalization. *IEEE Transactions on Signal Processing*, 48(11): 3217–3226, 2000.
- [6] .Chen, B. Mulgrew, and S. McLaughlin. Adaptive Bayesian equalizer with decision feedback. *Signal Processing*, 41(9): 2918–2927, 1993b.
- [7] Patra, W.C. Chin, P.K. Meher, and G. Chakraborty. Legendre-FLANN-based nonlinear channel equalization in a wireless communication system. In *IEEE International Conference on Systems, Man and Cybernetics*, pages 1826–1831, 2008.
- [8] K. Burse, R.N. Yadav, and S.C. Shrivastava. Channel equalization using neural networks: A review. *IEEE Transactions on Systems, Man and Cybernetics, Part C (Applications and Reviews)*, 40(3): 352–357, 2010.
- [9] R-C. Lin, W-D. Weng, and C-T. Hsueh. Design of an SCRFNN-based nonlinear channel equalizer. *IEEE Proceedings-Communications*, 152(6): 771–779, 2005.
- [10] J.C. Patra, W.B. Poh, N.S. Chaudhari, and A. Das. Nonlinear channel equalization with QAM signal using Chebyshev artificial neural network. In *IEEE International Joint Conference on Neural Networks*, pages 3214–3219, 2005.
- [11] E. Soria-Olivas, J.D. Martin-Guerrero, G. Camps-Valls, A.J. Serrano-Lopez, J. Calpe-Maravilla, and L. Gomez-Chova. A low-complexity fuzzy activation function for artificial neural networks. *IEEE Transactions on Neural Networks*, 14(6): 1576–1579, 2003.
- [12] W. Xu, Z. Zhong, Y. Be'ery, X. You, and C. Zhang. Joint neural network equalizer and decoder. *arXiv:1807.02040v1*, 2018.
- [13] Tang, C. Deng, and G. Huang. Extreme learning machine for multilayer perceptron. *IEEE Transactions on Neural Networks And Learning Systems*, 27(4): 809–821, 2016.
- [14] S. Yang, Y. Han, X. Wu, R. Wood, and R. Galbraith. A soft decodable concatenated LDPC code. *IEEE Transactions on Magnetics*, 51(11): 1–4, 2015.



**Impact Factor:
7.569**



INTERNATIONAL JOURNAL OF INNOVATIVE RESEARCH

IN SCIENCE | ENGINEERING | TECHNOLOGY

 9940 572 462  6381 907 438  ijirset@gmail.com



www.ijirset.com

Scan to save the contact details