



e-ISSN: 2319-8753 | p-ISSN: 2347-6710

# IJRSET

International Journal of Innovative Research in  
**SCIENCE | ENGINEERING | TECHNOLOGY**



# INTERNATIONAL JOURNAL OF INNOVATIVE RESEARCH

IN SCIENCE | ENGINEERING | TECHNOLOGY

Volume 12, Issue 5, May 2023

**ISSN** INTERNATIONAL  
STANDARD  
SERIAL  
NUMBER  
INDIA

Impact Factor: 8.423



# Design and Fabrication of Hydraulic Bearing Puller and Pusher

Ashish Singh<sup>1</sup>, Mukesh Rahangadale<sup>2</sup>, Tejas Wadibhasme<sup>3</sup>, Satyendra Kanojiya<sup>4</sup>, Sanketkumar Tembhare<sup>5</sup>, Dinesh Katre<sup>6</sup>, Prof. Gaurav Nagdeve<sup>7</sup>

Department of Mechanical Engineering, Abha Gaikwad-Patil College of Engineering and Technology, Mohgaon, Nagpur, India

**ABSTRACT:** Now a day's hydraulic system plays very important role in almost all the application. As in automobile industries, small service center, aircraft industries and used where precision is required. Traditional method of bearing removal or installation is hammering, but unnecessary hammering causes several problems. The unsafe and excessive hammering cause's damage of bearing surface or sometimes chance to failure and excessive human effort required. In order to remove or installed bearing safely, to make modification in traditional method. The modification made in easy removing and installing bearing. The purpose of modification are required less human effort, simplicity of operation, Removing and installing bearing done without damaging bearing surface, compact, portable and well suited. The hydraulic bearing puller based on hydraulic system on the principle of Pascal's law which states that " Pressure distribution in enclosed cylinder is uniform in all direction

A Hydraulically operated bush bearing puller is a device which enables the single persons to operate it alone and removes the bearing the from machine parts. No special skill is needed to operate or remove the bush bearing form the machine parts. It can widely used. It is easy to fit on the operate or remove the bearing from the machine parts.. This device is worked by the principle of hydraulic lifting system to exert the pulling power to remove the bearing from the machine blocks. This is operated by hydraulic power

Without use of man power. As the bottom flange has a hole which is set below the bottom portion of the bush bearing in the machine block, makes to provide grip for pulling the bush bearing. Through this bottom flange hole a screw rod inserted. he other end of the screw rod is connected to the top flange which is moving towards upward direction by the action of hydraulic jack. If we lift the jack, the top flange pulled the centre rod. So the centre rod rises with bottom flange gradually with the liner. Thus the liner is removed.

**KEYWORDS:** Bearing puller, Bearing pusher, Pascal's law, Hydraulic jack, Principle of hydraulics, CAD model.

## I. INTRODUCTION

In hydraulic bearing puller and pusher is a special arrangement which will be attached to a hydraulic jack, bearing clamp and shaft clamp respectively. First we use hydraulic jack. There after the hydraulic jack is connected to the bearing clamp with the help of pusher arrangement. Then the shaft clamp is attached with the help of stud rod which is connected to the jack plate. In order to maintain geometrical precision and the surface integrity of ball and roller bearing raceways and rolling elements, it is mandatory that care in storage, handling and installation be observed. The hydraulic bearing puller and pusher perform both pulling and pushing operation safely and without harming bearing surfaces. The Hydraulic Bearing Puller and Pusher was developed by Rakesh Y. Suryawanshi in which [1] the machine is a arrangement of for removing as well as installing bearing on the shaft. Hydraulic pulling consists of adjustable mechanical jaw puller inbuilt with the hydraulic jack. When pump operated, plunger comes outside. Then mechanical jaws adjusted bellow the bearing and again operate the pump.

## II. OBJECTIVES

By using hydraulic bearing puller equal and consistent force is applied so that bearing can easily removed from the shaft without damaging surface finish of the shaft. Same as in mounting the bearing on the shaft in reverse fashion.

Less human effort is required.

Time is reduced.

Bearing and shaft are not damage during mounting and removal.

Overall production is increased.



III. DISCRPTION

1. Hydraulics’:

The word hydraulics’ concerned with study of behaviour of water at rest and at motion i.e. behaviour of liquids. Hydraulics’ includes properties, advantages and applications of liquids. The two main scientists give the direction to forward, one is Daniel Bernoulli and another is Blasé Pascal. Bernoulli's conducted an experiment on fluid flow and gives fluid flow equation to the world and at same period Pascal developed science of hydraulic

2. Pascal’s law :

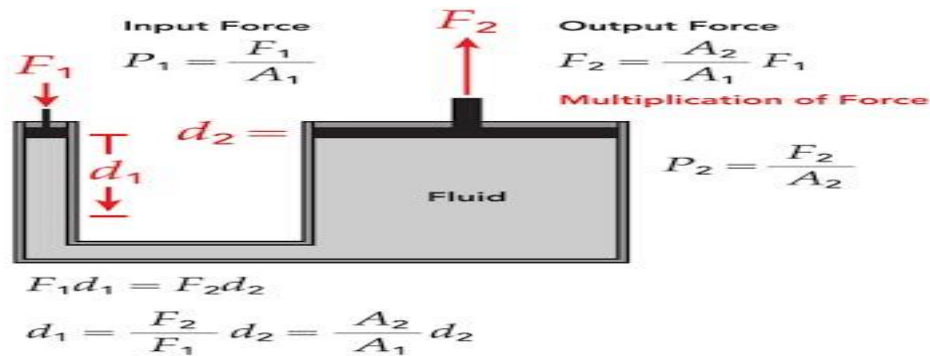

Fig. 1 Pascal’s law [2]

Pascal's law (also Pascal's principle or the principle of transmission of fluid-pressure) is a principle in fluid mechanics states that a pressure change occurring anywhere in a confined incompressible fluid is transmitted throughout the fluid such that the same change occurs everywhere. The law was established by French mathematician Blaise Pascal in 1647–48.

According to Pascal’s Law, Pressure or intensity of pressure at a point in a static fluid will be equal in all directions. In order to understand how hydraulic system depends over Pascal’s law, we will consider following case.

As we can see in above figure, area  $A_2$  is larger as compared to area  $A_1$  hence it will require less force to lift the heavy load.

3. Bearing installation and removal basics :

- Mechanical Removal, Installation And Methods
- Thermal Removal, Installation & Methods



Fig.2 Manual method [2]



Fig.3 Thermal method [2]

#### IV. WORKING AND DESIGN

Hydraulic puller and pusher perform both the operation i.e. removal of bearing and installation respectively. Hydraulic pulling consists of bearing clamp with the hydraulic jack. When jack operated, plunger comes outside. Then bearing clamp goes upward direction and bearing is installed on shaft. During operation, hydraulic jack applies continuous pressure on shaft with the help of pusher pin and remove bearing from shaft.

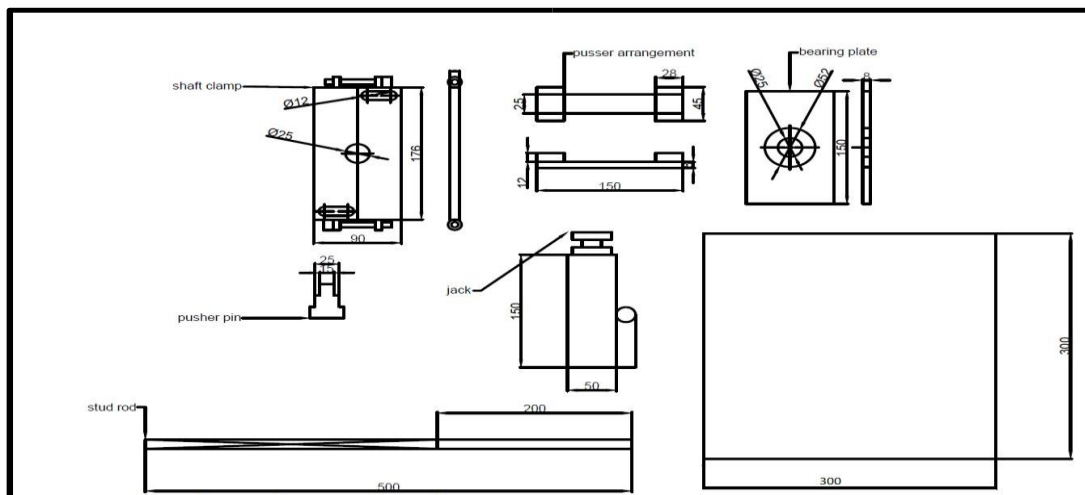

Fig. 4 Detail drawing

#### 2. Design Consideration:

- Load capacity of Hydraulic Jack (W) = 5 ton (50 KN)
- Operating Pressure (p) = 80 Kgf
- Lift Range (L) = 15 cm
- Man effort put on handle (e) = 20Kg
- Permissible tensile stress of mild steel ( $\sigma_t$ ) = 120 N/mm<sup>2</sup>
- No. of stroke for lifting load (n) = 150
- Factor of safety = 5
- Permissible shear stress of mild steel ( $\tau$ ) = 20 N/mm<sup>2</sup>
- Permissible comp. stress of mild steel ( $\sigma_c$ ) = 20 N/mm<sup>2</sup>



- Permissible comp. stress of cast iron ( $\sigma_c$ ) = 120 N/mm<sup>2</sup>
- Permissible shear stress of cast iron ( $\tau$ ) = 35 N/mm<sup>2</sup>

#### Design of Hydraulic Jack: 1)

- The material of hydraulic jack is cast iron and having capacity of 5 ton. Material used for handle and jack plate is mild steel.
- Outer diameter of jack ( $D_o$ ) = 50 mm
- Inner diameter of jack ( $D_i$ ) = 20 mm
- Oil capacity in reservoir at bottom of jack = 200 ml
- Handle attached to jack ( $l*b*t$ ) = (280 mm\*10 mm\*8 mm)
- Vertical stud rod attach to both sides diagonally to the jack plate ( $l$ ) = 500 mm

#### Design of bearing clamp: 2)

- Puller plate dimension ( $l*b*t$ ) = (150 mm\*90 mm\*8 mm)
- Upper hole on bearing clamp = 52 mm
- boring height on bearing clamp = 5 mm
- Hole on bearing clamp = 25 mm

#### Design of Shaft Clamp: 3)

Material used for shaft clamp is mild steel. During pushing operation of bearing, shaft clamp plays very important role i.e. to hold the shaft.

- Diameter of shaft ( $D$ ) = 50 mm
- Shaft clamp Dimension ( $l*b*t$ ) = ( 180 mm\*90 mm\*10 mm)
- Central hole on clamp plate of diameter = 50 mm
- slot on clamp plate for vertical stud of diameter = 36 mm
- Slot diameter = 12 mm

#### Design of pushing Arrangement: 4)

The material used for pusher is mild steel. Pusher is made like C frame having horizontal stripes on which two vertical strips welded at the end of horizontal strips . The two horizontal loads welded on vertical strips.

- Horizontal strip dimension ( $l*b*t$ ) = ( 150 mm\*25 mm\*8mm)
- Horizontal load strips dimension ( $l*b*t$ ) = ( 45 mm\*28 mm\*12mm)

#### Design of pusher pin 5)

The material used for pusher is mild steel it is use for puss shaft in bearing removing process. □ Diameter of pin ( $D$ ) = 15 mm

1. AutoCAD model:-

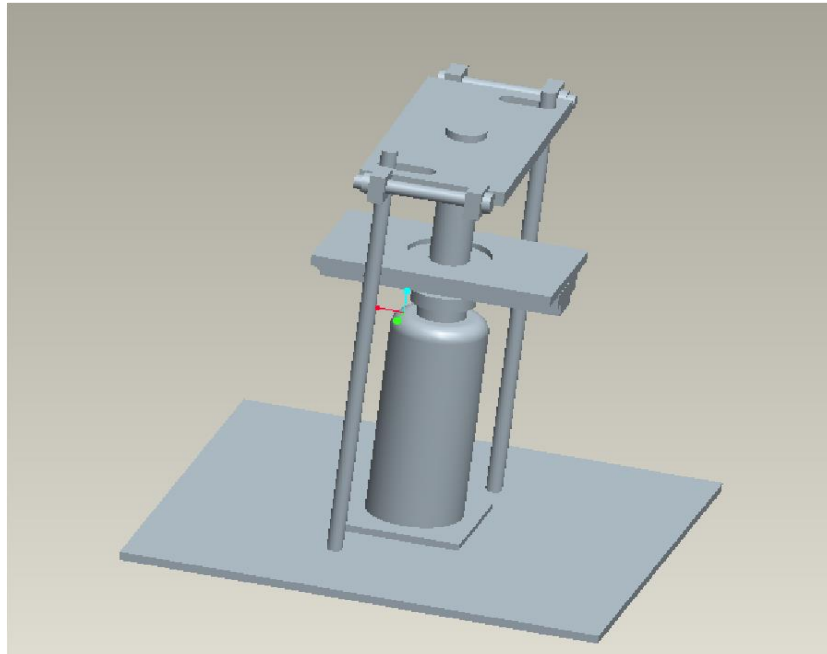

Fig 5 conceptually design



Fig.6 Actual model of hydraulic bearing puller and pusher.



## V. CONCLUSION

In order to remove and installed bearing safely, to make modification in traditional method. The modification made in installing and easy removing bearing. The purposes of modification are Simplicity of operation, removing and installation of bearing done without damaging bearing surface, compact, portable, well suited, low cost, Multifunctional ,safe ,versatile.

## REFERENCES

- [1] A.V. Vanalkar Design and Fabrication of Hydraulic Bearing Puller and Pusher IJIRST –International Journal for Innovative Research in Science & Technology| Vol 1 | Issue 11 | April 2015ISSN (online): 2349-6010..
- [2] Mohan Krishna S. A. Experimental Design And Fabrication of A portable Hydraulic Pipe Bending machine, International Journal of Development Research ISSN: 2230-9926Vol. 4, Issue, 12, pp. 2681-2684, December, 2014.
- [3] Prof R.V. Chaudhary Design And Development of Pipe Bending Machine. ISSN : 2249-5770..
- [4] Prof. Nilesh Nirwan and Prof. A.K. Mahalle, Department of Mechanical Engineering, G.H. Raisoni college of engineering Nagpur has found a Portable Rolling Pipe Bending Machine.In april,2013..
- [5] Prof. A. Pandiyan Department of Mechanical Engineering, of Saveetha School of engineering Chennai has found a Zigzag Pipe Bending Machine In Nov, 2015.
- [6] Sachin throatdesign of a hydraulic operated bearing puller International Journal of innovation in Engineering and Technology,Vol.2 Issue 2 April 2013 ISSN:2319-1058.. [7] M. Huaeto study thecontinuous plate edge bending mode of the four roll bending process1997. Serope, Manufacturing Processes for Engineering Materials, Addison Wesley, USA, Edition 3..
- [8] Mohanraj G Thydraulic operated bearing pullerInternational Journal for Innovative Research in Science & Technology| Volume 2 | Issue 11 | April 2015ISSN (online): 2349-6010..
- [9] N. SaravananDesign and Fabrication of Hydraulic Rod Bending MachineInternational Journal of Innovative Research in Science, Engineering and Technology An I SO 3297 : 2007 Certified Organization, Vol.3 , Special Issue 2 , April 2014 Sec Dulkeshwar Vaidya Shreyas .P. Bisan Sarthak .V. Shende Vipul .A. Chavan



**INNO SPACE**  
SJIF Scientific Journal Impact Factor  
**Impact Factor: 8.423**



**ISSN** INTERNATIONAL  
STANDARD  
SERIAL  
NUMBER  
INDIA



# INTERNATIONAL JOURNAL OF INNOVATIVE RESEARCH

IN SCIENCE | ENGINEERING | TECHNOLOGY

**9940 572 462** **6381 907 438** **ijirset@gmail.com**



[www.ijirset.com](http://www.ijirset.com)

Scan to save the contact details