



e-ISSN: 2319-8753 | p-ISSN: 2347-6710

IJRSET

International Journal of Innovative Research in
SCIENCE | ENGINEERING | TECHNOLOGY



INTERNATIONAL JOURNAL OF INNOVATIVE RESEARCH

IN SCIENCE | ENGINEERING | TECHNOLOGY

Volume 12, Issue 5, May 2023



Impact Factor: 8.423

Smart Door Unlock System using Fingerprint

Shubhangee Sutar¹, Ankita Chopdar², Mokshada Vibhute³, Radhika Somani⁴

U.G. Student, Department of Electronics and Telecommunication Engineering, Parvatibai Genba Moze College of Engineering, Wagholi, Pune, Maharashtra, India¹

U.G. Student, Department of Electronics and Telecommunication Engineering, Parvatibai Genba Moze College of Engineering, Wagholi, Pune, Maharashtra, India²

U.G. Student, Department of Electronics and Telecommunication Engineering, Parvatibai Genba Moze College of Engineering, Wagholi, Pune, Maharashtra, India³

Assistant Professor, Department of Electronics and Telecommunication Engineering, Parvatibai Genba Moze College of Engineering, Wagholi, Pune, Maharashtra, Engineering, India⁴

ABSTRACT: This concept of a fingerprint door locker is related to the security issues in today's life. The physical key can be made as a duplicate at a very cheap cost, and the key can be lost somewhere or stolen. To overcome these issues, we can use biometric security gadgets and try to improve the security much more because it can never be stolen, it cannot be lost, and the stealing chance of duplication is very low to break the security. In the old days, security was a big issue for the company's houses and other places, and every person is worried about security now. So, a solution to such problems can be found by combining door locks with biometrics. Biometric verification is any means by which a person can be uniquely identified by evaluating one or more distinguishing biological traits. Unique identifiers include fingerprints, hand geometry, earlobe geometry, retina and iris patterns, voice waves, DNA, and signatures. The fingerprint sensor will take the fingerprint of the user and forward it to the microcontroller to match with its records. If the print matches one of the fingerprints in the microcontroller's memory, the microcontroller will lock or unlock the latch based on its current state. If the fingerprints do not match, then nothing happens. The door lock is unlocked, and the user has to retry. The system will be reset once a known print is entered. Here we will use fingerprints for biometric verification as they are one such thing that is unique to every individual, and the use of fingerprints as the key to door locks can overcome the security problem of unauthorised people trespassing into our homes, shops, offices, etc. to a great extent as duplicates of such keys are not possible. Also, this system will not lead to problems like losing keys because we do not require carrying keys if this system is used instead of traditional locks. So, using Arduino, we will try to implement the system with features that will increase the security level.

I. INTRODUCTION

These days, office and corporate environment security is a major threat faced by every individual when away from home or at home. When it comes to security systems, it is one of the primary concerns in this busy, competitive world where humans cannot find ways to provide security to their confidential belongings manually. Instead, he or she finds an alternative solution that provides better, more reliable, and more atomized security. This is an era where everything is connected through networks, and anyone can get hold of information from anywhere around the world. Thus, the chances of one's information being hacked are a serious issue. Due to these risks, it's very important to have some kind of personal identification system to access one's own information. Today, personal identification is becoming an important issue everywhere. Among mainstream personal identification methods, we mostly see password and identification card techniques. But it is easy to hack passwords now, and identification cards may get lost, thus making these methods quite unreliable. There are certain situations that are very annoying, like when a person locks himself out of his house or office, leaves his key inside, or sometimes when a thief just breaks the lock and steals everything. These kinds of situations always trouble people who use manual door locks with keys. Although in some places people use smart cards, there might arise a situation when someone loses the card or keeps the card inside. In other scenarios, caretakers are responsible for locking houses or offices and keeping the keys safe. But then again, there are times when the person in charge of the keys might not be available or have gone to some emergency routine, which can cause an unwanted delay for people who need the key



straightaway. These are some of the hassles that people might face when using keys or smart cards. That is when our system, the fingerprint door lock system, comes into play. Our design is implemented to provide better security, as users don't need to remember passwords and don't need any sort of keys or cards that often get lost. If someone's fingerprint is authorised in the systems, he or she would not face any sort of delay in entering a room. Fingerprint recognition is one of the most secure systems because the fingerprint of one person never matches that of another. Therefore, unauthorised access can be restricted by designing a lock that stores the fingerprints of one or more authorised users and unlocks the system when a match is found. Biometric authorization proves to be one of the best traits because the skin on our palms and soles exhibits a flow-like pattern of ridges on each fingertip that is unique and immutable. This makes fingerprints a unique form of identification for everyone. The popularity and reliability of fingerprint scanners can be easily guessed from their use in recent hand-held devices like mobile phones and laptops. This paper is about solving the problem of unauthorised people trespassing in our homes, shops, or offices. Security issues can be fixed using traditional locks, but there is always the possibility of someone opening the lock even without breaking it with the use of a duplicate key. Using these kinds of locks also creates problems if we lose keys, and we also have to carry keys along with us always. Again, using patterns in the locks can increase security, but again, they can be opened if somehow the passwords or patterns are known. So, leaving every system in this project, we will implement a system using biometrics. In the case of biometrics, the pattern that will be used as a key will be unique. Here, to implement the project, we will use fingerprints as the key. This Arduino project will make use of different devices for the implementation of the security lock, where there will be different features to increase the security level. In simple words, we can say that we are implementing a door access system using Arduino that makes use of fingerprints to identify who to allow and who not to allow inside our homes, offices, shops, etc. We are trying to implement it using a normal and simple door lock, which is fitted in every home, so as to minimise the cost of the device as a product..

II. RELATED WORK

The purpose of this experiment is to implement a door-locking mechanism that opens or closes the lock on the door automatically with a key code. There are two work processes for this experiment, which are: Case 1: The lock will open. In this system, the user will enter their fingerprint into the fingerprint scanner, which is connected to the door latch through the microcontroller. After scanning the print, the system runs its database and looks for a match. If any match is found, the latch opens, and thus the door gets unlocked. The same thing happens when the user wants to lock the door. A correct fingerprint makes the latch close, locking the door behind the user. Case 2: The lock will not open. If the fingerprint is wrong, the lock will not open, allowing the door to remain locked and the user to retry until the door is opened. Scanning the wrong fingerprint will automatically instruct the user to start again from the beginning.

Description of the important component: First of all, we use Proteus software to complete the simulation. In this simulation, we've used some important components to build the whole door-locked system, which are the Arduino UNO R3 V1.0, LED Green, LM044L 16x2 Alphanumeric Display, Fingerprint, Door Lock, 12V Adapter, Speaker, Transistor IRFZ44N, and TIP122.

Arduino UNO R3 V1.0

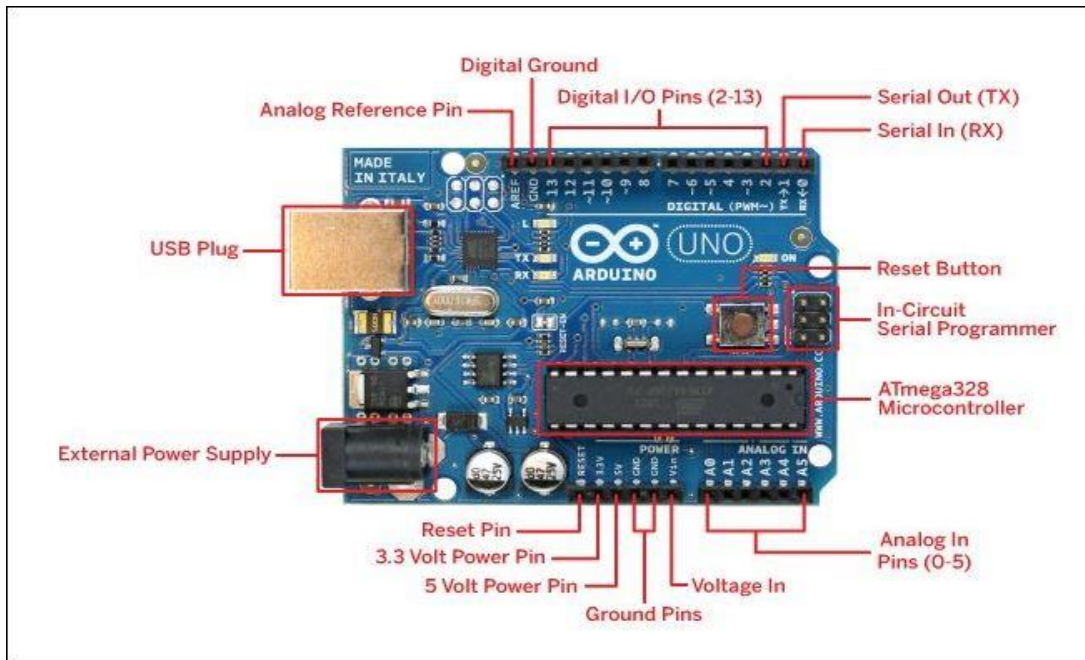

III. METHODOLOGY

The circuit shown in Fig. 1 operates using a 12V power supply. An Arduino microcontroller (MCU) requires only 5 volts, but the solenoid electric lock requires 12V. As Arduino Uno has an inbuilt 5V voltage regulator, a common 12V supply can be in-built the whole system.

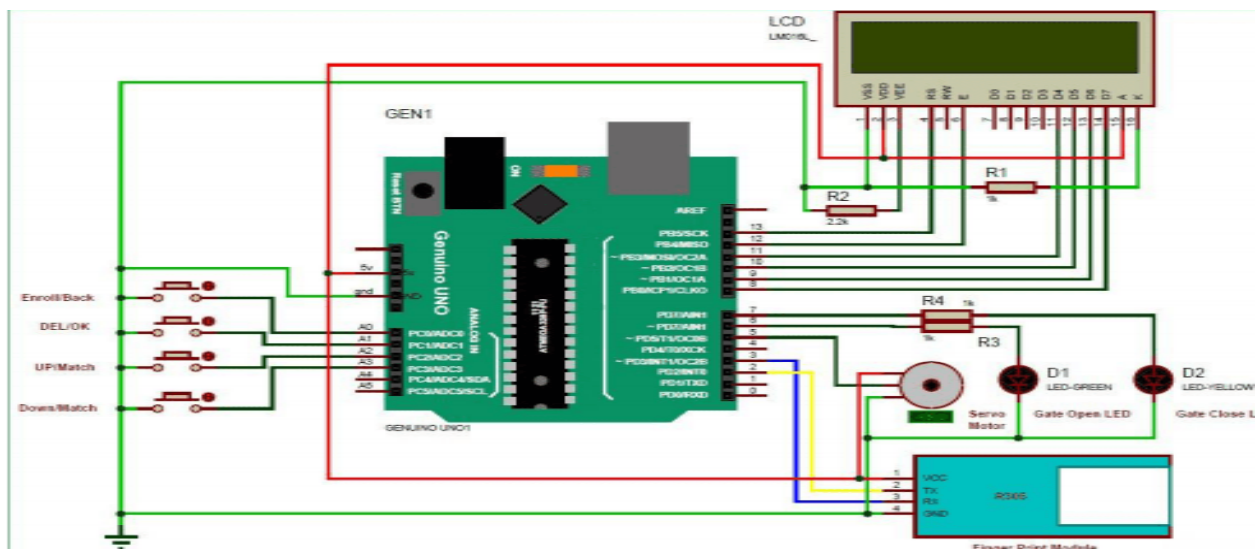

IV. EXPERIMENTAL RESULTS

For the fingerprint door lock using Arduino, we are showing the components and connecting them to the power supply. This system is based on improving security by registering the owner's fingerprint into the Arduino using the fingerprint sensor, and in this system, we have given the Arduino a 5-volt power supply through the code uploading wire. When



you put your thumb on the fingerprint sensor after registering yourself, the lock will be unlocked. If you repeat this process again, the solenoid lock will be locked. The process of locking and unlocking requires less than 1 second, so this is why the solenoid lock is used in this project.

V. CONCLUSION

The design and implementation of a fingerprint-based door lock system are customizable and flexible. This door locking mechanism is comparatively more cost-effective than the available lock systems in the traditional market. Our fingerprint-based lock system has a high accuracy rate and is quick to recognise fingerprints, which enables seamless integration with the users and provides tighter security. In our country, private and government organisations are very concerned about security. Many companies are interested in using this type of locking mechanism, but the systems that are available have very high installation costs. Due to this excessive cost, many small firms cannot afford such systems. Keeping the installation cost in mind, we planned to develop a system that should be affordable to both large and small firms. This design can be improved by more intensive development, and additional features, such as more locks, can be added to the system. Thus, we do not need to spend so much on just one lock if this can be used to control several doorways. A system to save prints without the use of a computer could have been made, but it would require more parts than the ones we used. In order to maintain security properly, the whole mechanism should be placed inside the door panel or on the other side of the door. A system for batteries could also be made or even be solar-powered. One of the main advantages of this system is its flexibility. Several other systems can be implemented with this system. The system is very secure. Fingerprints are unique, and the sensor is able to identify all of the prints during testing. It provides greater control over access to restricted places. There are some drawbacks to this system, such as the fact that it is complicated and difficult to make any changes to the hardware as it is a closed system. Also, it needs high power to operate, so providing continuous power through batteries is a challenge sometimes. A power failure will make it unworkable. In that case, we can connect the system with an IPS or add rechargeable batteries to the system. [21]

REFERENCES

1. "Password-Based Door Lock System Using Arduino," Research Gate. https://www.researchgate.net/publication/330998913_Password_Based_Door_Lock_System_Using_Arduino (accessed Aug. 8, 2021).
2. Meenakshi, N., M. Monish, K. J. Dikshit, and S. Bharath "Arduino-Based Smart Fingerprint Authentication System." In the 2019 1st International Conference on Innovations in Information and Communication Technology (ICIICT), 1–7 Chennai, India: IEEE, 2019.
3. Patil, Karthik A., Niteen Vittalkar, Pavan Hire Math, and Manoj A. Murthy "Smart Door Locking System Using IoT" 07, no. 05 (2020): 5.
4. Reddy, R Sai Charan, P Vamsi Krishna, M Krishna Chaitanya, M Neeharika, and K Prabhakara Rao "Security System Based on Knock Pattern Using Arduino and GSM Communication," 4, no. 1 (2018): 5.
5. Areed, Marwa F. "A Keyless Entry System Based on an Arduino Board with Wi-Fi Technology." *Measurement* 139 (June 2019): 34–39. <https://doi.org/10.1016/j.measurement.2019.02.028.67f>.



SJIF Scientific Journal Impact Factor

Impact Factor: 8.423



INTERNATIONAL JOURNAL OF INNOVATIVE RESEARCH

IN SCIENCE | ENGINEERING | TECHNOLOGY

 9940 572 462  6381 907 438  ijirset@gmail.com



www.ijirset.com

Scan to save the contact details