



e-ISSN: 2319-8753 | p-ISSN: 2347-6710

IJRSET

International Journal of Innovative Research in
SCIENCE | ENGINEERING | TECHNOLOGY



INTERNATIONAL JOURNAL OF INNOVATIVE RESEARCH

IN SCIENCE | ENGINEERING | TECHNOLOGY

Volume 12, Issue 5, May 2023



Impact Factor: 8.423

Home Security System Using Zigbee

¹Dr. Navnath Narawade, ² Harshada S.Ghanwat, ³Harshada P. Bhondwe, ⁴ Mrunal M. Divase

¹Professor Department of Electronics and Telecommunication Engineering, Parvatibai Genba Moze college of Engineering, Wagholi, Pune, Maharashtra, Engineering, India,

²U.G. Student, Department of Electronics and Telecommunication Engineering, Parvatibai Genba Moze college of Engineering, Wagholi, Pune, Maharashtra, India

³U.G. Student, Department of Electronics and Telecommunication Engineering, Parvatibai Genba Moze college of Engineering, Wagholi, Pune, Maharashtra, India

⁴U.G. Student, Department of Electronics and Telecommunication Engineering, Parvatibai Genba Moze college of Engineering, Wagholi, Pune, Maharashtra, India

ABSTRACT-Security is the most important in our day-to-day life. A special security is essential for homes. In today's run-off life we sometimes neglect the protection of our homes. Without such security system, a major disaster can happen at any time. In worst case this may also lead to a loss of life. So, there is a need to avoid such things and protect our home automatically. So, we propose a home security system. The system will operate independently even we are not at home. The system gives warning and the worst case scenario can be prevented easily. Our system will provide effective security solution against any kind of threatening like human intrusion, fire, door tampering, gas leakage etc. A real time and true model home sensors and transducers will be used in this project along with a camera unit for continuous security monitoring

KEYWORDS: Firefightingrobot;compactsize robot;ultrasonicsensor;flamesensor;remotecomrol

I. INTRODUCTION

security is a worldwide concerned issue. The security system has been enhanced through applying various ways, for example, by employing many security officers, using innovative weapons, alarms, control system, producing electronic hardware and software and many more, currently, many studies on smart systems of home have been carried out covering all aspects; for instance, multimedia, lighting, security monitoring, temperature control ... etc., in a smart system of home, the tendency is towards the use of an automated system helping users to monitor the situation of home; accordingly, simplifying and accelerating daily works. Hence, the effects of human errors can be avoided by utilizing automatic systems and then saving electricity [1]. The advantages of using Zigbee & Arduino controllers providing low data rate transmission, low energy consumption, ease in setting up the network and low costs together with smaller sensor size. Zigbee is the most widely deployed enhancement to the IEEE 802.15.4 standard where the organization maintains, supports, and develops more protocols for advanced applications in defining additional communication features [2] This paper presents the development and implementation of a low cost system for home security using two type of controllers (Zigbee & Arduino) and microcontroller development board connected with three sensors, buzzers, display unit, Bluetooth devices and GUI (Graphical User Interface). The rest of this paper is organized as follows; section 2 describes the methodology and approach, software and hardware configuration and the experiment setup of the home security system using (Zigbee & Arduino)

II. METHODOLOGY

The basic flowchart of research methodology and approach is shown in Fig. 1. This research comprises two parts, namely hardware and software. The implementation of hardware requires designing research circuit and the development of a PCB. After completing both parts, the next process is to test and debug the system. The block diagram of the proposed security system of home is shown in Fig. 2. This block diagram comprises two sides, namely transmitter and receiver. A WSN standard is used to connect all components. When the sensor detects any change it sends a signal to the controller (Arduino Mega) which analyzes this signal and transmits it to the second controller

(Arduino Uno) wirelessly using Zigbee. After that, the Arduino Uno transmits the data to the GUI.

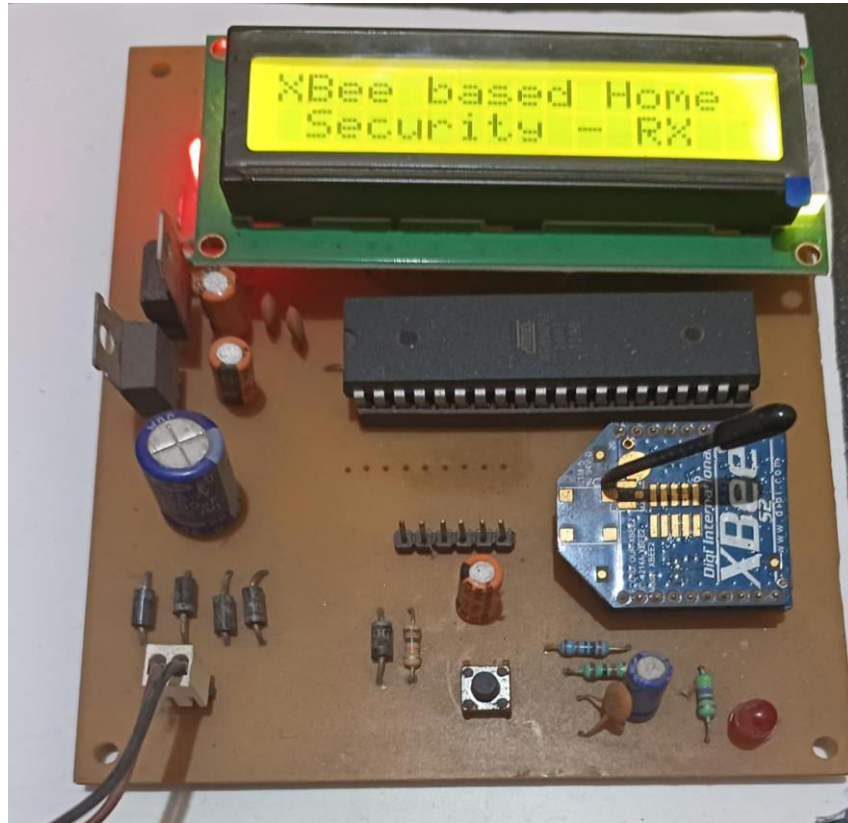

Fig.1 Circuit of the Project.

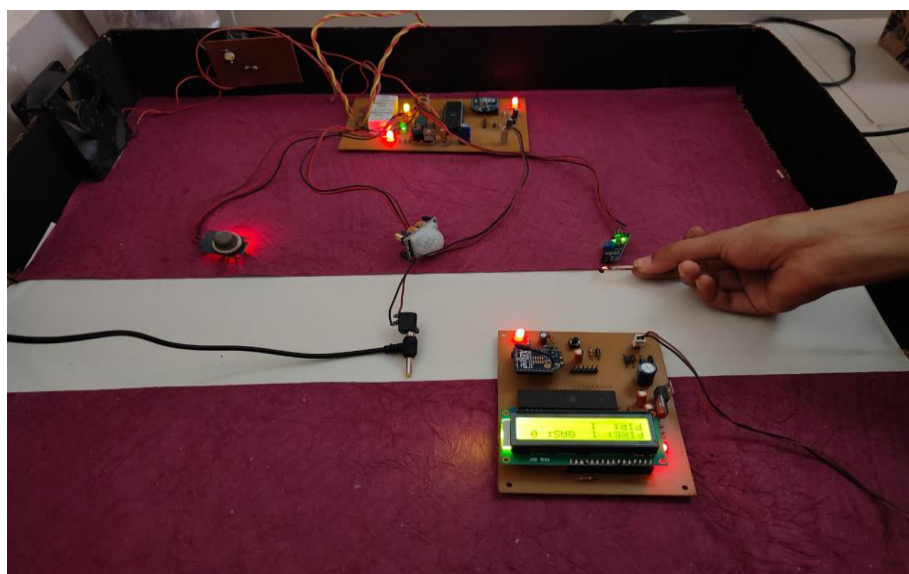

Fig.2.Model of Project.

A. Hardware Implementation

In this section discusses the design and function of components connected to Arduino for constructing the security system. Moreover, it describes the process of making the circuitry connection between microcontroller and



components.

- 1) Microcontroller: In this system, microcontroller AT89C52 is used. The digital output of each sensor is fed to the AT89C52. It also drives the relay through the relay driver IC ULN2003. It actually senses the sensor output and turns ON the respective actuator through relay.
- 2) Human Intruder Sensor: The PIR sensor, short for Passive Infrared sensor, is a cost-effective device designed to detect the presence of humans or animals. This sensor utilizes two crucial components. Firstly, a pyroelectric crystal detects heat signatures emitted by living organisms, enabling it to identify human or animal movement. Secondly, a Fresnel lens is incorporated to expand the sensor's detection range. The white-colored structure associated with the sensor serves as a lens, widening its coverage area. However, if you remove the lens, you will uncover the pyroelectric sensor itself, encased in a protective metal housing as depicted below. The sensor operates in two modes: Repeatable (H) and Non-Repeatable (L). The Repeatable mode is the default setting.
- 3) Relays: Relays are switching that open and close circuits electromechanically or electronically. In this system, the relays are used to turn ON the actuators that are exhaust fan, water sprayer and light with respect to output of particular sensor. The control circuit functions as the coupling between the input and output circuits. In electromechanical relays, the coil accomplishes this function. The output circuit of a relay is the section responsible for activating the load, serving a similar purpose as the mechanical contacts found in electromechanical relays.

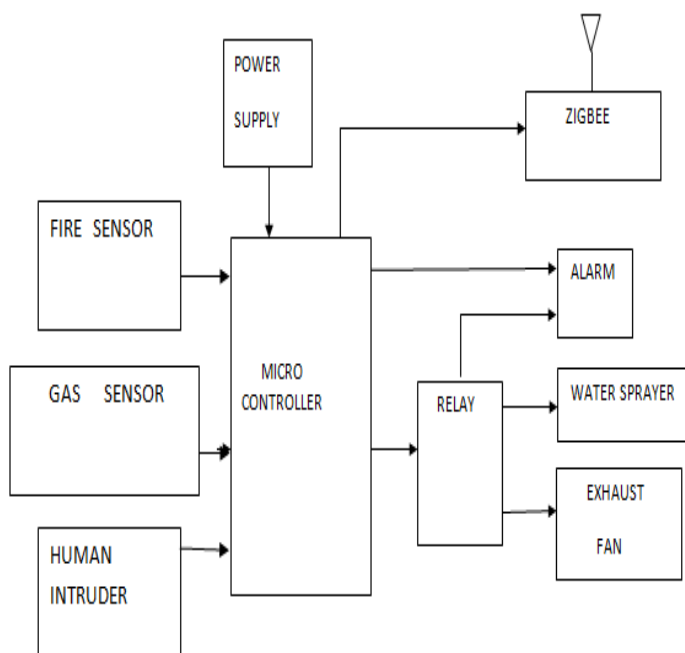

Fig.3.Block Diagram of System.

- 4) ZigBee Module: ZigBee is a wireless communication technology developed by the Zigbee Alliance as an open global standard, specifically designed to meet the unique requirements of low-cost, low-power wireless sensor networks. In this system, the ZigBee module is utilized for transmitting signals in the event of any potential threats. Two ZigBee modules are employed: one for transmitting signals from home to the control room, and another for receiving those signals at the control room.

ZigBee modules are a compact family of radio devices that operate on the ZigBee or 802.15.4 protocol. Zigbee is a standardized technology that caters to the specific needs of affordable and energy-efficient wireless sensors. It can be implemented in various settings and boasts ease of use and minimal power consumption. These modules employ relatively low-power 2.4GHz or 900 MHz bands to transmit and receive data, enabling the establishment of simple point-to-point connections or complex self-healing networks spanning extensive areas. Additionally, interfacing a

device with a ZigBee module is a straightforward process. Zigbee technology, as defined by the Zigbee Alliance, aims to provide a simpler and more cost-effective alternative compared to other wireless technologies like Bluetooth. Essentially, Zigbee serves as a transceiver module.

IV. CONTROLLING

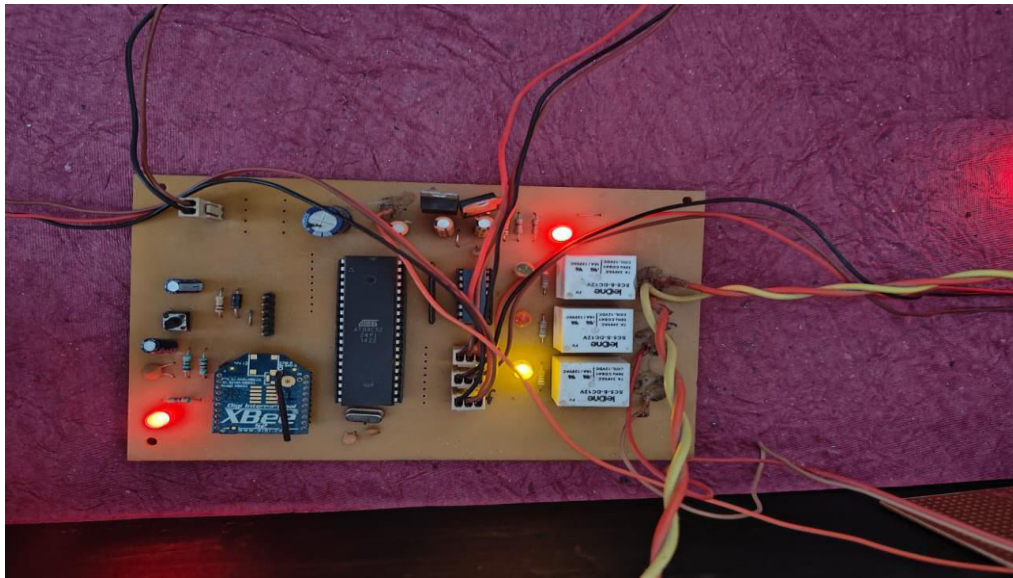

Fig.4. Transmitter of Project

V. RESULT

Safety is paramount for a secure and protected life. Therefore, our wireless-based automatic home security system is designed to offer comprehensive protection against various threats, including fire, human intrusion, and gas leakage. By ensuring seamless transmission of signals to the control room, the system enables prompt response and facilitates efficient management of potential hazards. Additionally, we have implemented a rescue system within the home, enabling effective control and mitigation of critical situations such as fire or gas leakage. The system provides timely warnings, allowing for swift preventive measures in worst-case scenarios. With its robust capabilities, our security solution offers an effective and reliable safeguard against a wide range of threats

VII. CONCLUSIONS

In this project, the ZigBee communication protocol offers promising prospects for enhancing home security. We have conducted a comprehensive evaluation of the current state of home automation and security systems. Within our system, it becomes effortless to monitor the status of the external environmental conditions. The utilization of ZigBee communication technology not only reduces the overall cost of the system but also minimizes the intrusiveness during installation. Looking ahead, numerous additional features can be incorporated, such as voice-activated home automation, by implementing more robust and efficient techniques to ensure enhanced security.

REFERENCES

- [1] Nidhi Patel, Hiren Kathiriya and ArjavBavarva, "Wireless Sensor Network Using Zigbee", International Journal of Research in Engineering and Technology, 2(6), 1038 (2013)
- [2] Dr. Subhi R. M. Zeebaree and Hajar M. Yasin, "Arduino Based Remote Controlling for Home: Power Saving, Security and Protection", International Journal of Scientific & Engineering Research, 5(8), 2229 (2014).
- [3] SubhankarChattoraj, "Smart Home Automation based on different sensors and Arduino as the master controller", International Journal of Scientific and Research Publications, 5(10), 1 (2015).



- [4] Gutierrez, Jose .A, "Wireless Medium Access Control (MAC) and Physical Layer (PHY) Specifications for Low-Rate Wireless Personal Area Networks (LR-WPANs) ".
- [5] Ajinkya Kumar Jadhav and SnehalGaherwar, "Development of Wireless Ordering System for Hotel", Certified Journal, 5(1), 2250 (2015).
- [6] Zipporah Tarus, "PIR Sensor Based Security System", Bachelor of Engineering Thesis, University of Applied Sciences, Helsinki Metropolia, (2017). J. Lee, G. Park, J. Shin and J. Woo, Industrial robot calibration method using denavit — Hatenberg parameters, 17th International Conference on Control, Automation and Systems (ICCAS), 2017, pp. 1834- 1837.



INNO SPACE
SJIF Scientific Journal Impact Factor
Impact Factor: 8.423



ISSN INTERNATIONAL
STANDARD
SERIAL
NUMBER
INDIA



INTERNATIONAL JOURNAL OF INNOVATIVE RESEARCH

IN SCIENCE | ENGINEERING | TECHNOLOGY

 **9940 572 462**  **6381 907 438**  **ijirset@gmail.com**



www.ijirset.com

Scan to save the contact details