

# An Overview of X-By Wire Systems

Balajee S B<sup>1</sup>, Balaji P<sup>1</sup>, Shreyas J<sup>1</sup>, Satheesh K<sup>2</sup>

UG Student, Easwari Engineering College, Chennai, India<sup>1</sup>

Assistant Professor, Easwari Engineering College, Chennai, India<sup>2</sup>

**ABSTRACT:** Nowadays many advanced technologies are incorporated with many disciplinary like mechanical, electrical, electronics, communication etc. Recent researches concentrate more on material reduction and safety features. This gives automotive industry a new concept called x-by wire systems in order to reduce some components with enhanced safety. The advancements in today's car give more comfortable to the driver and passenger. Embedded electronics, and more precisely embedded software, is a fast growing area, and software based systems are increasingly replacing the mechanical and/or hydraulic ones. The reasons for this evolution are technological as well as economical. This paper gives a clear overview on x-by wire systems. "X" stands for the commanded action such as accelerating, braking and steering. By introducing x-by wire systems, large number of components will be replaced by electronic circuits and actuators.

**KEYWORDS:** Steer by wire, Brake by wire, Throttle by wire, x-by wire systems

## I. INTRODUCTION

The 20th century was full of inventions in the field of automation. The anti-lock braking system was first developed for aircrafts the ABS is an automobile safety system that allows the wheels on a motor vehicle to maintain tractive contact with the road surface according to the drivers input of braking, preventing the vehicle from locking up and avoiding uncontrolled skidding. The EPS (electric power steering) was introduced in vehicles which gave a very comfortable driving facility by using hydraulic and electrical actuators to add up power to the steering without gear steering effort of the driver.

In the year 1983, the electronic stability control was introduced which increased the dynamic stability of the vehicle by deducting and reducing skidding. Then the traction control system came into existence which is nothing a secondary function of EPS.

Embedded electronics and more precisely embedded software is a fast growing area almost in all the core fields of engineering. The hike development of electronics has replaced many mechanical and hydraulic systems due to its better precision and cost efficiency. This trend resulted in the introduction of X-by-wire concept, where mechanical and hydraulic systems in an automotive application will be replaced completely by electronic ones. The x-by-wire concept refers to the replacement of mechanical, hydraulic or other such conventional systems with electronic systems.

The first by-wire systems have been developed in aviation. In huge aircraft hydraulic and mechanical connections between input devices of a pilot and the actuators (for example flaps and fin) have been replaced by electronic wires. The pilot gives his commands by the cockpit controls to a flight control computer FCC, which controls several electro motors and hydraulic pumps [5].

Chevrolet corvette in the year 1980 introduced the concept of throttle by wire which is also known as gear by wire, implemented in some high end vehicles such as BMW 5&7 series.

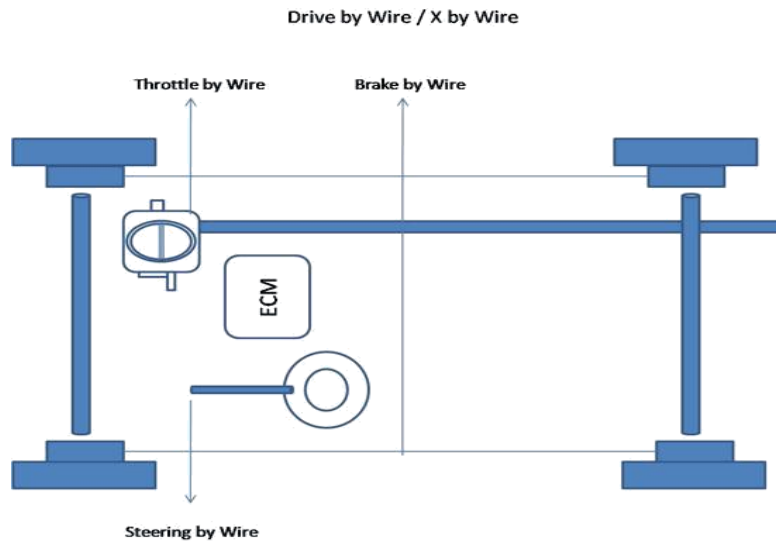

Figure.1. x-by wire (Source: [7])

## II. STEER BY WIRE SYSTEM

The steer by wire technology replaces the conventional steering system of the vehicle; it provides an increased comfort to the driver by varying the steering ratio and adapting the wheels to driving conditions. A steer by wire system provides two main services: Controlling the wheel directions according to the drivers request and providing mechanical like force feedback to the steering.

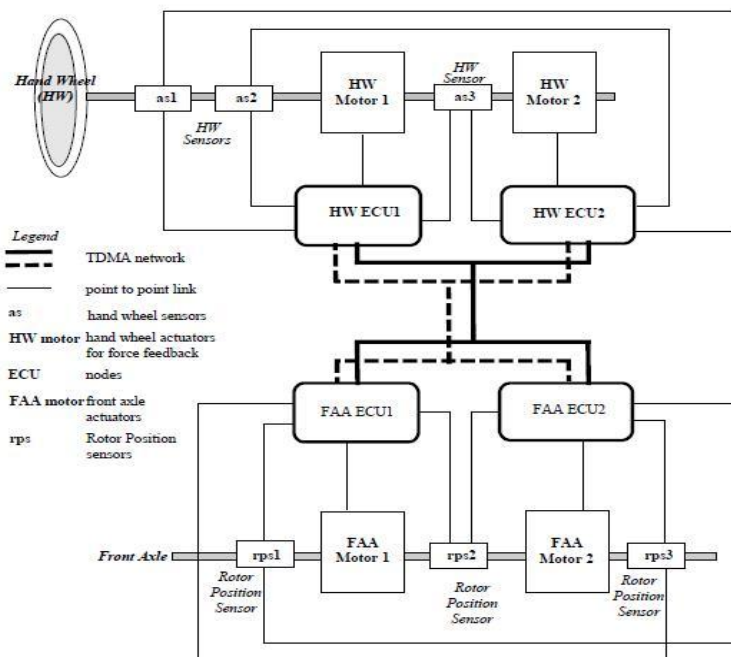

Figure.2. Steer by wire (Source: [4])

## International Journal of Innovative Research in Science, Engineering and Technology

An ISO 3297: 2007 Certified Organization

Volume 4, Special Issue 3, March 2015

First National Conference on Emerging Trends in Automotive Technology (ETAT-2015)

Organized by

SAE INDIA Velammal Collegiate Club, Velammal Engineering College, Chennai, India on 20<sup>th</sup> March 2015

Figure 1 illustrates the hardware architecture on which the operational one is based. It includes four Electronic Control Units (micro-controllers) named, respectively, HW ECU1 (Hand Wheel ECU1), HW ECU2 (Hand Wheel ECU2), FAA ECU1 (Front Axle Actuator ECU1), and FAA ECU2 (Front Axle Actuator ECU2). Each node is connected to the two TDMA-based communication channels (BUS1 and BUS2). Finally, three sensors, named as1, as2 and as3, placed near the hand wheel measure the requests of the driver in a similar way, the latter being translated into a 3-tuple <hand wheel angle, hand wheel torque, hand wheel speed. Three other sensors, named rps1, rps2 and rps3, are dedicated to the measurement of the front axle position.

Finally, two motors (FAA Motor1 and FAA Motor2), configured in active redundancy, act on the front axle while two other motors (HW Motor1 and HW Motor2) realize the force feedback control on the hand wheel. Sensors as1, as2 and as3 (respectively, sensors rps1, rps2 and rps3) are connected by point-to-point links, both to HW ECU1 and HW ECU2 (respectively, FAA ECU1 and FAA ECU2).

### Implementation of the “Front axle control” function

The requests of the driver are measured by the three replicated sensors as1, as2 and as3 and sent to both HW ECU1 and HW ECU2. Each ECU performs a majority vote on the 3 received values and transmits a “secure” data on both communication channels BUS1 and BUS2. The two

ECUs, FAA ECU1 and FAA ECU2, placed behind the front axle, consume this data, as well as the last wheel position, in order to elaborate the commands that are to be applied to FAA Motor 1 and 2.

### Implementation of the “Force feedback control” function

In a way similar to the previous function, measurements taken by rps1, rps2 and rps3 are transmitted both to FAA ECU1 and FAA ECU2. Each of these ECUs elaborates information transmitted on the network. The consumers of this information are both HW ECU1 and HW ECU2 which compute the command transmitted to HW Motor 1 and 2.

The replication of algorithms on several ECUs, of measurements from several similar sensors and of information transmission over redundant buses is highly used in this operational architecture. The choices made in terms of redundancy and diversifications are constrained by dependability, cost and dimension requirements.

## III. BRAKE BY WIRE SYSTEM

The brake -by-wire system replaces the conventional braking system with one micro-controller and one actuator per wheel which can increase the quality of braking i.e. it reduces the stopping distance.

The advantages of brake-by-wire systems are:

- \* The weight of the vehicle is reduced because the hydraulic brakes are replaced by electronic ones.
- \*There is no need of braking fluid which decreases the pollution in the aspect of eco-friendly solution.

The first brake-by-wire technology was introduced in Electro Hydraulic Braking in which each wheel is installed with an independent braking system.

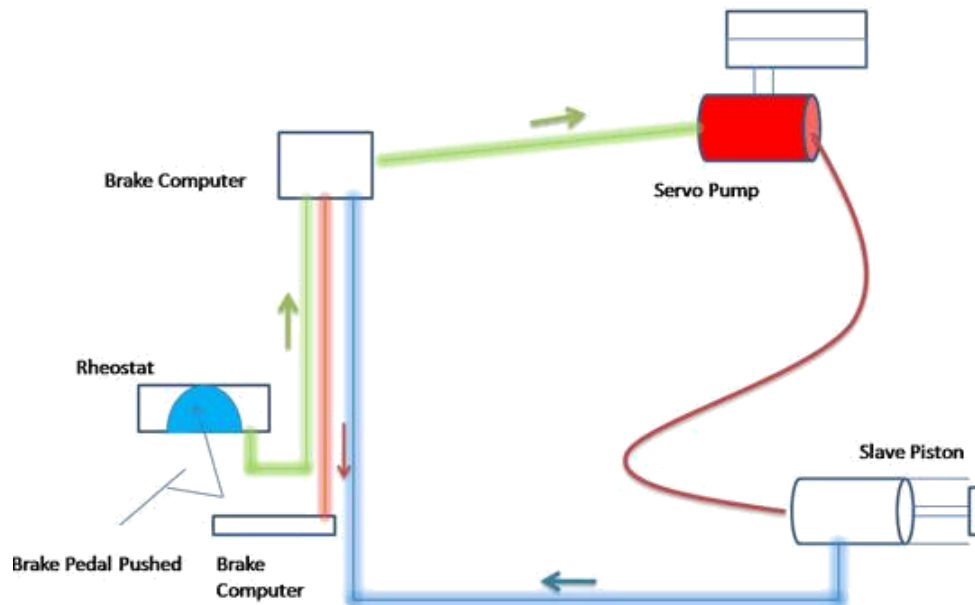

**Figure.3. Brake by wire (Source: [7])**

**Working:** This system consists of a rheostat that senses the position of the brake pedal. This signal is interpreted by the brake computer, which generates signals to operate a servo pump. The pump pressurizes the secondary circuit and brake fluid pushes against a slave piston that activates the brake. The pressure is monitored and a signal is sent back to the brake computer, which applies a mechanical force to the pedal as feedback to the driver.

#### **IV. THROTTLE BY WIRE SYSTEM**

Throttle-by-wire is an automotive technology that is widely used on vehicles today. It replaces the traditional throttle linkage (a cable between the accelerator pedal and the throttle) with an accelerator pedal position sensor and an electronically operated throttle. It provides several advantages over mechanical systems:

- Eliminates binding problems in mechanical linkages preventing the throttle from sticking
- Allows automated control of the throttle that helps to reduce emissions and improve fuel economy
- This system can be modeled and installed as a modular system
- Allows the ECM to integrate torque management with cruise control, traction control and stability control

**Working:** The accelerator pedal sensor senses the position of the accelerator pedal. This information is conveyed to the ECM as a change in the electrical resistance. The ECM actuates a servo-motor, which actuates the butterfly valve in the throttle assembly. The position of the throttle is continuously monitored and the information is conveyed to the ECM using a feedback circuit.

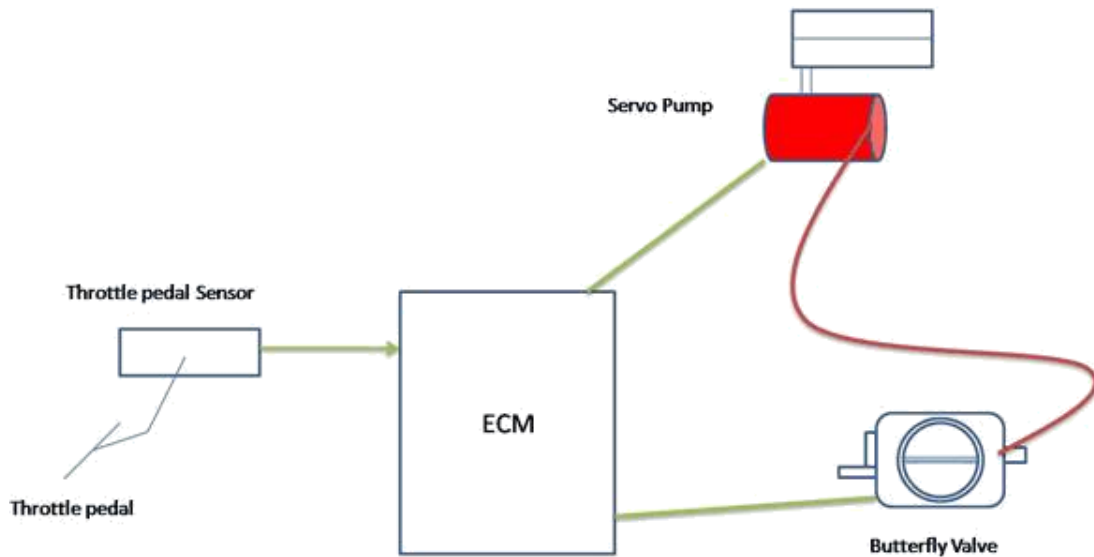

Figure.4. Throttle by wire (Source: [7])

**V. COMMUNICATION SERVICES OF X-BY-WIRE SYSTEMS TIME TRIGGERED PROTOCOL (TTP)**

In time triggered protocol the activities are driven by the progressive combination of both time and event triggering. The dependability and safety factor of an x-by-wire system increases by the usage of time triggered bus. The signals given by the time triggered protocol can be used as heart beats for detecting failures. The time triggered protocol is defined at the central part of the architecture and it possesses numerous features and services related to dependability. The TTP protocols have been designed and extensively studied at the Vienna University of Technology.

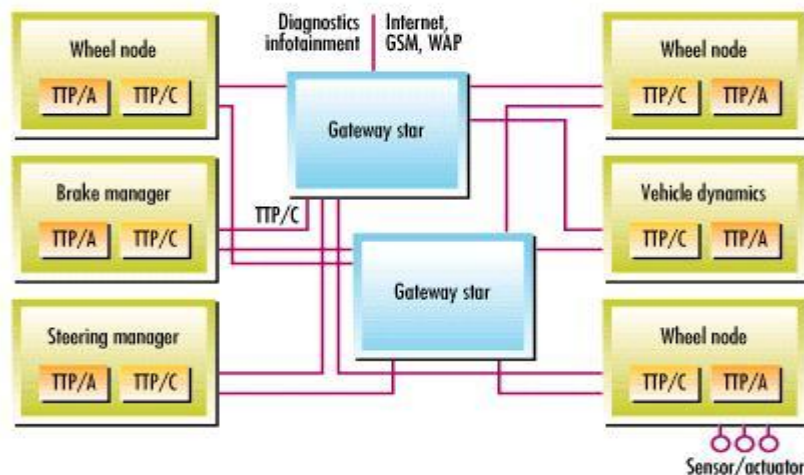

Figure.4. Throttle by wire (Source: [9])

**VI. FLEXRAY**

The flexray is an automotive network communication protocol developed by Flexray consortium team to govern onboard automotive computing. Its designed to be faster and more reliable than TCAN and TTP, but it is also more expensive. The flexray can have two independent data channels for fault tolerance the bus operates on time settings. The first series production vehicle with flexray was at the end of 2006 in the **BMW x-5**. The full use of flex ray was introduced in 2008 in the new **BMW 7 series**.

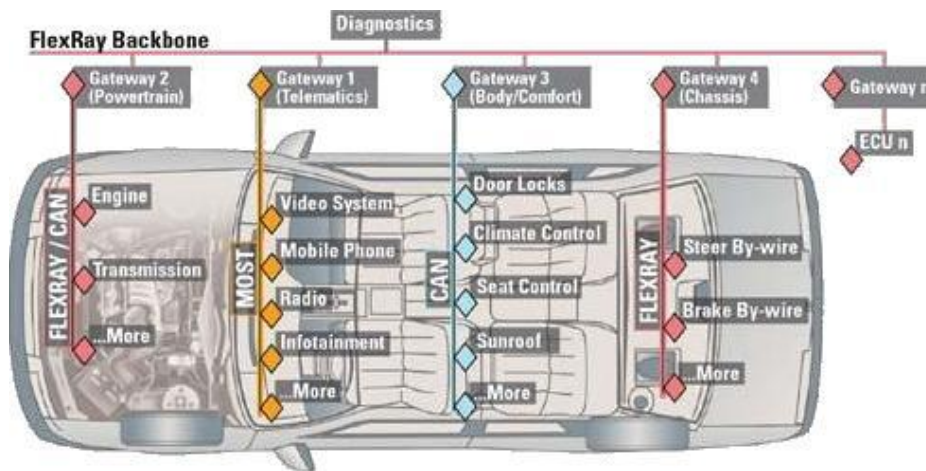

Figure.6. (Source: [8])

**VII.TTCAN**

It is the acronym of time triggered control area network and it is a communication protocol developed by Robert Bosch on the basis of control area network and data link layer. The TTCAN is built on a well mastered and cheap technology but does not provide many dependability services. Nowadays TTCAN system is extensively used until the flexray technology is fully matured.

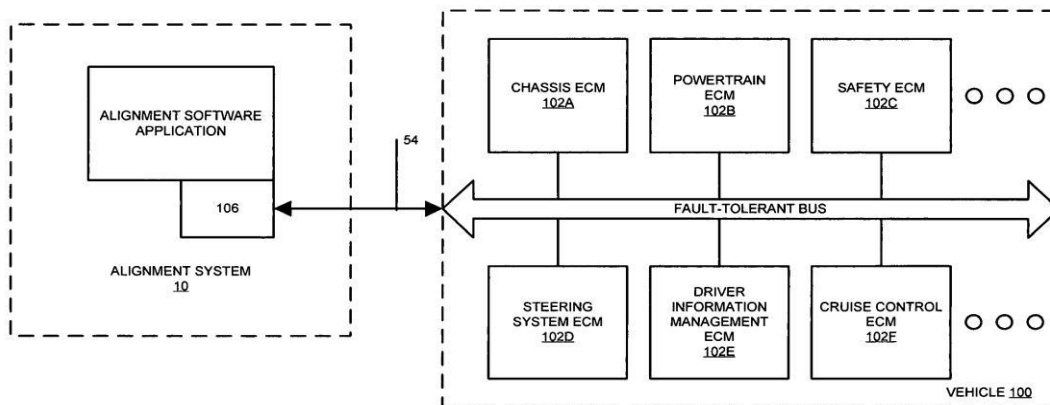

Figure.6. (Source: [10])



## International Journal of Innovative Research in Science, Engineering and Technology

An ISO 3297: 2007 Certified Organization

Volume 4, Special Issue 3, March 2015

First National Conference on Emerging Trends in Automotive Technology (ETAT-2015)

Organized by

SAE INDIA Velammal Collegiate Club, Velammal Engineering College, Chennai, India on 20<sup>th</sup> March 2015

### VIII. CONSTRAINTS OF THIS CONCEPT GENERAL CONSTRAINTS

Implementation of break by wire and steer by wire system requires a 42V battery in heavy vehicles, which is a major constraint. Another constraint is the Electronic based systems account about 30% of total cost of the vehicle.

#### Dependability constraints

According to the conclusions published by the X-by-wire Esprit project [6]. A critical X-by wire system must be ensured with

-A system failure must not lead to a state in which human life, economics or environment is affected.

-A single failure of one component must not lead to the failure of the whole X-by wire system. In case of loss of functionality the user must be able to reach a safe parking area.

#### Real time constraints

The X-by-wire system must respect certain time constraints such as sampling period of only a few milliseconds. The end to end response of a physical system must be lower than a few tens of milliseconds. Although electronic systems have a better precision, when it comes to real time situations like perturbations, road conditions and random loading the system is still in a rudimentary state.

### IX. INFERENCE

In general terms, for any ground vehicle the employ of electric drives in spite of the mechanical systems presently adopted for the transmission and actuation of the pilot's commands might permit to achieve significant improvements under several points of view. In fact, by-wire systems permit to easily adopt different optimized paths for the signal and for the power cables, which turns into an overall lower gross volume than required by conventional mechanical or hydraulic connections.

A far more flexible design of the vehicle results then possible, allowing optimizing the power train's layout basing on structural considerations, to increase and make more comfortable the payload space, and to shape as desired the pilot command interface. This fact may turn into a higher passive safety of the vehicle, since parts that become notoriously dangerous in case of accident, such as the steering column, the brake pedal and possibly also the steering wheel may be completely eliminated. The user interface may become also more user-friendly, for example requiring only hand commands through a cloche-like device that may completely replace the present pedals, levers and the steering wheel.

The overall performances of the vehicle may be also improved when the supervision system is enabled to apply suitable strategies even during normal operation, to optimize the vehicle's response basing on its current status, on the pilot directives and on other significant variables, such as road slope, pavement conditions etc. When fully exploited, this possibility should permit to further increase the active safety of the vehicle with respect to the presently existing partial systems, such as ABS.

Moreover, an accurate management of the engine and power transmission behavior, eventually joined with the adoption of an integrated starter-alternator system, may permit to achieve significant fuel savings and pollution reductions by optimizing the combustion process and

## International Journal of Innovative Research in Science, Engineering and Technology

An ISO 3297: 2007 Certified Organization

Volume 4, Special Issue 3, March 2015

First National Conference on Emerging Trends in Automotive Technology (ETAT-2015)

Organized by

SAE INDIA Velammal Collegiate Club, Velammal Engineering College, Chennai, India on 20<sup>th</sup> March 2015

selecting the best engine speed and gear ratio per each operating condition. Further fuel savings should also derive from and overall higher efficiency of several auxiliary systems, such as pumps and compressors, which are presently operated at randomly variable speed directly from the engine, and are often regulated in dissipative way acting on controllable output valves.

Finally, in amid-long term perspective even a cost reduction seems possible with respect to conventional systems: in fact, by-wire solutions should permit wider synergic savings by leveraging on the possible modularity of the subsystems, especially for what concerns control and data transmission apparatuses, although also the power devices may be used to equip different vehicles featuring similar sizes.

### X. CONCLUSION

X-BY-WIRE system is a clear trend of automotive development due to the advantages in electronic components for enhancing safety, functionality and reducing cost. Modern cars are equipped with drive-by-wire systems and a combined mechanical backup. In the future mechanical backup systems will be replaced by pure electronic solutions. The real rime constrains in the X-BY-WIRE system can be overcome by further research and analysis. The X-BY-WIRE system provides a better feature for automobile engineering with great precision and efficiency.

### REFERENCES

1. Fred Seidel, X-by-Wire, Chemnitz University of Technology, Operating Systems Group. February 25, 2009.
2. Oliver Rooks, Michael Armbruster, Armin Sulzmann, Gernot Spiegelberg, Uwe Kiencke, Duo duplex drive-by-wire computer system, Reliability Engineering and System Safety 89 (2005) 71–80.
3. S. Blanc, A. Bonastre, P.J. Gil, Dependability assessment of by-wire control systems using fault injection, Journal of Systems Architecture 55 (2009) 102–113.
4. Cédric Wilwert, Design of automotive X-by-Wire systems.
5. APOLLO SOFTWARE. Airbus flybywire - how it really works. [http://www.apollosoftware.com/products/FlyByWire/FlyByWire\\_english.pdf](http://www.apollosoftware.com/products/FlyByWire/FlyByWire_english.pdf)
6. X-by-Wire Project, Brite-EuRam 111 Program, X-By-Wire - Safety Related Fault Tolerant Systems in Vehicles, Final Report, 1998.
7. [http://www.cvel.clemson.edu/auto/AuE835\\_Projects\\_2009/pillai\\_project.html](http://www.cvel.clemson.edu/auto/AuE835_Projects_2009/pillai_project.html)
8. <http://www.win.tue.nl/~mheuvel/projects.html>
9. [http://www.eetimes.com/document.asp?doc\\_id=1224993](http://www.eetimes.com/document.asp?doc_id=1224993)
10. <https://www.knigozal.com/store/gb/book/ttcan-grundlagen-fuer-eine-C2%B5c-software/isbn/978-3-639-04631-1>