

International Journal of Innovative Research in Science, Engineering and Technology

(An ISO 3297: 2007 Certified Organization)

Vol. 4, Issue 3, March 2015

Smart Car Features Using Embedded System and IOT

ANITHA M. T.

Lecturer in Electronics, Government Polytechnic College, Chelad P.O., Kothamangalam, Kerala, India

ABSTRACT: Advancements in automobiles and self-driving vehicles have risen tremendously in the last decade. Increased automobile use has led to an increase in the number of safety concerns. There has been a dramatic increase in the number of accidents and life-threatening injuries. Adequate safety features in autos have become a legal requirement. When a vehicle crashes and its location is detected, the system sends an alarm to the police and the user's family members, as well as providing a panic button for the passenger's safety. Additionally, we exhibit a cabin monitoring system and an interactive interface between a user and a car in which a user may send a text message to the car's GSM module to query about temperature, humidity, and other factors within the vehicle. The GSM module connects to the Arduino, which retrieves sensor values and transmits them to the user through text message.

KEYWORDS: Child presence detection, in-car monitoring, smart car, wireless artificial intelligent

I. INTRODUCTION

The Smart Car application has attracted a lot of attention because of the rising use of IoT in automotive Embedded Systems. When the owner is not there, it is extremely difficult to locate lost automobiles in large urban areas or to track down any thefts that may have taken place. The Internet of Things (IoT) refers to the smart gadgets and sensors that are distributed in the environment and connected so that they may gather, share, and integrate data. Many new Internet-of-things (IoT) devices are intended to make it easier for individuals to have a better knowledge of how humans interact with their surroundings. [1] The expansion of wireless radio equipment, pervasive wireless signals, and the wealth of information brought into wireless signals by human activities have all been predicted to make wireless sensing a dominant solution for IoT applications.

Everything from automobiles and bridges to hospitals and industries is equipped with embedded systems. These systems may be found in everything from mobile phones and virtual reality headsets to our clothes and even in our houses. It's only a matter of time before more and more embedded systems are included into equipment. Emerging embedded systems technology can be seen in the ITS sector. [2] When it comes to ITS, embedded systems are involved in reducing pollution, fuel consumption, and road deaths in automobiles and public infrastructures. Vehicle-to-vehicle or vehicle-to-road infrastructure communication in the background of active safety systems necessitates interconnection with various devices.

II. REVIEW OF LITERATURE

Borgonovo et al. [3] smart parking solutions will benefit a wide range of urban stakeholders, who all bear the burden of carelessly managed parking spaces in one way or another. For example, it is expected that these systems will have a favourable effect on the number of traffic accidents, i.e., crashes caused by a lack of driver attention as they race to find parking spaces or rush to fill existing ones.

International Journal of Innovative Research in Science, Engineering and Technology

(An ISO 3297: 2007 Certified Organization)

Vol. 4, Issue 3, March 2015

According to Weber [4], a private company using IoT should incorporate data authentication, access control, resilience to assaults, and client privacy into their business activities, which would be an extra advantage. ' According to Weber, IoT developers must take the geographical limits of different countries into account when defining global security and privacy issues. Weber. In order to address privacy and security concerns on a worldwide scale, a standard framework must be developed. Preparation for the full-fledged operational IoT framework should begin with an investigation of privacy and security concerns.

Heer et al. [15] later discovered a security vulnerability in IP-based IoT systems. They claimed that the internet is the backbone of an IoT system's connectivity between devices. Because of this, IP-based IoT security is a major concern. In addition, the security architecture of an IoT system should be created taking into account the life cycle and capabilities of each object. The trusted third party and security protocols are also involved. The IoT security architecture that has the flexibility to grow from small to large-scale devices is a must. Traditional end-to-end internet protocols are unable to handle IoT's new form of communication among various things on the network, according to the findings of the study.

Using photoelectric sensors dispersed over long distances before and after traffic lights, Ahmed S. Salama et al (2010)[6] propose an integrated intelligent traffic light system for roads. Traffic signals must be opened immediately in the event of an emergency, such as when the president's car passes or an ambulance arrives. Emergencies that require a complete path to the destination can be handled by the system; however, this system does not work effectively if there are multiple emergencies at once. Vehicles come from both sides of the signal.

It was proposed by ManojKantaMainali et al (2010)[7] to use a genetic algorithm to predict the traffic volume in road segments without access to segment-specific traffic data. It is possible to predict the unknown traffic volume using only the existing data. So, the proposed ITSC system takes advantage of the AVR-32 and genetic algorithm combination to develop a very efficient system.

The traffic light controller designed by ShilpaS.Chavan et al (2009)[8] addresses a major issue with conventional traffic signals. Traffic lights at certain intersections may remain red for a predetermined amount of time even when there is no traffic, and road users must wait for the light to change to green. GSM is being used as a means of solving this problem, however the system has its drawbacks. The suggested ITSC system uses a genetic algorithm to overcome this issue.

Objectives

- Eye-blink sensors are installed in automobiles to verify that the driver is not drowsy.
- In order to avoid a collision, a proximity sensor is used to locate the obstruction ahead of the vehicle.
- The location of the wrecked car is determined using a GPS system, and an alert is issued to a responsible and authorised party to assure post-crash safety. A vibration sensor picks up the accident's vibrations.
- To ensure that the motorist is not drunk, use a gas sensor. Only when the driver is sober will the engine start.

III. RESEARCH METHODOLOGY

It is the systematic, theoretical investigation of the methods used in a particular field of research. Theoretical analysis of a branch of knowledge's methodologies and principles is included. Parameters like paradigm, theoretical model and phases are typically included in this type of research. Secondary sources must be thoroughly reviewed and analysed in order to use analytical and descriptive methodologies to the research.

International Journal of Innovative Research in Science, Engineering and Technology

(An ISO 3297: 2007 Certified Organization)

Vol. 4, Issue 3, March 2015

Close reading of a few secondary materials would be necessary to expand the textual analysis and provide additional perspectives.

IV. RESULT AND DISCUSSION

A major advantage of Wi-Fi over dedicated sensors is that it may be used to connect passengers and drivers in the automobile to the internet while going, whereas dedicated sensors can only sense. According to the diagram in fig. 1[9], radio waves can bounce back and forth inside an automobile because the metal exterior acts as an antenna.

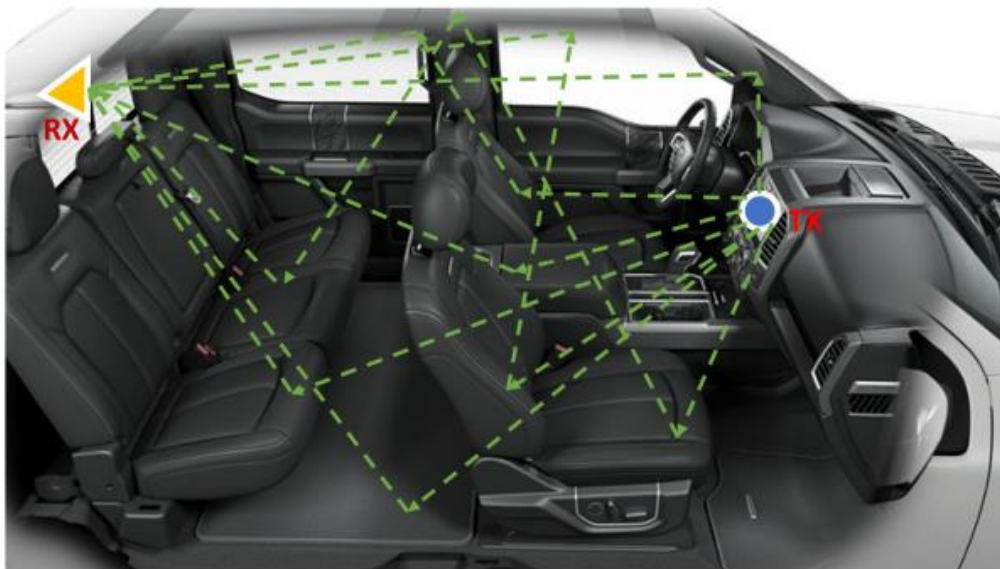

Multipath propagation in automobiles is seen in Fig. 1.

Because radio waves cannot pierce metal, radio waves only travel inside the metal box that makes up the interior of an automobile. Second, because the gearbox, engine, and wheels are all outside the primary payload and hidden by metal, movement of the car has little impact on internal propagation. [10]

The Internet of Things (IoT) is a new paradigm that allows electrical gadgets and sensors to communicate with each other via the internet in order to make our lives easier and more enjoyable. As a result of the internet and smart devices, IoT has the potential to address a wide range of economic, governmental and public/private sector issues worldwide [11].

International Journal of Innovative Research in Science, Engineering and Technology

(An ISO 3297: 2007 Certified Organization)

Vol. 4, Issue 3, March 2015

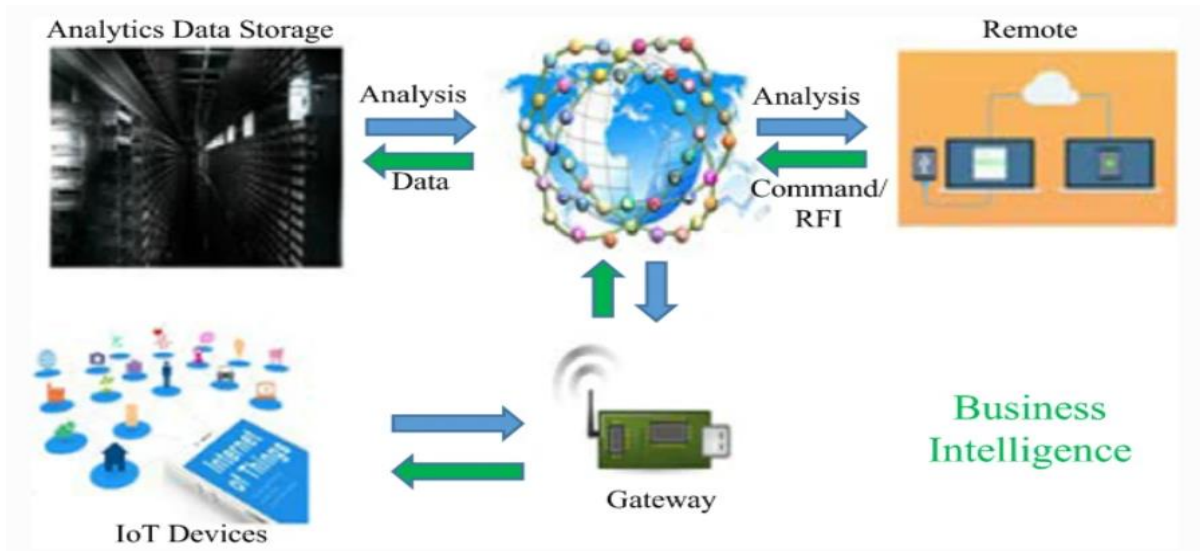
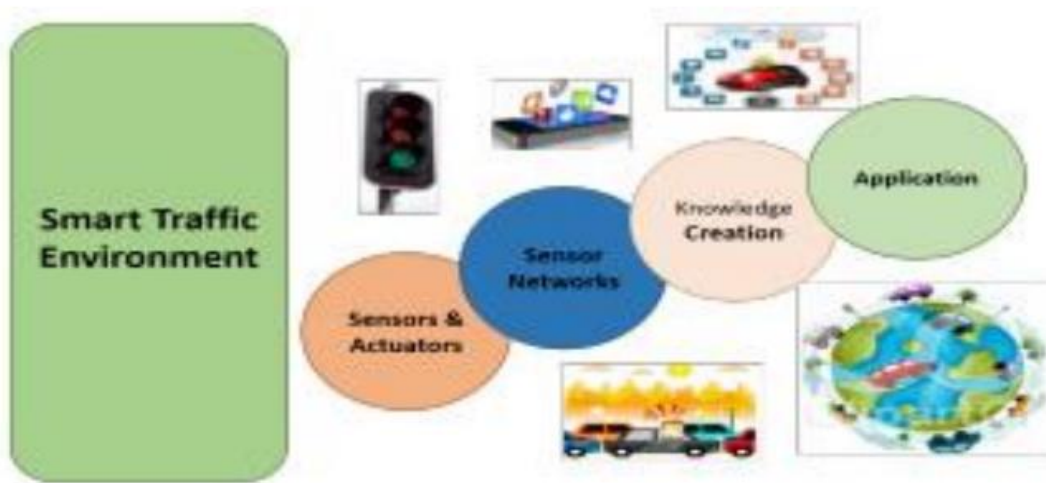

Figure 2: The IoT's Overarching Architecture

The IoT is becoming an increasingly pervasive part of our daily lives. Overall, the Internet of Things (IoT) is a breakthrough innovation that brings together a wide range of smart systems, frameworks and smart devices. [12]

Determined by the control decision, which traffic streams will be given a green signal Interval microscopy is used to estimate the consequences of control operations in small time intervals in accordance with the proposed strategy. It's a useful tool for comparing the length of time it takes for different vehicles to reach their destinations. Traffic congestion is one of the most common problems in large cities. [13]



IoT and Smart Traffic Management are shown in Fig. 3

International Journal of Innovative Research in Science, Engineering and Technology

(An ISO 3297: 2007 Certified Organization)

Vol. 4, Issue 3, March 2015

Fig. 3 depicts the project's block diagram and the components it requires. The Raspberry Pi single-board computer used for embedded applications was utilised to design this project. Sensors such as door sensors, proximity sensors, and Wi-Fi dongles are some of the interfacing components that are employed. Using the 32-bit ARM controller on the Raspberry Pi, the CPU Core can be used. In the event that a car is stolen or mishandled, the driver is notified via the APP and can activate the Tracking system, which will enable the camera and begin tracking the GPS location. [14] Users can choose if they want the gadget to save the Internal or External Image. In order to do this, simply rotate the camera that is attached to the CAR's rear-view mirror.

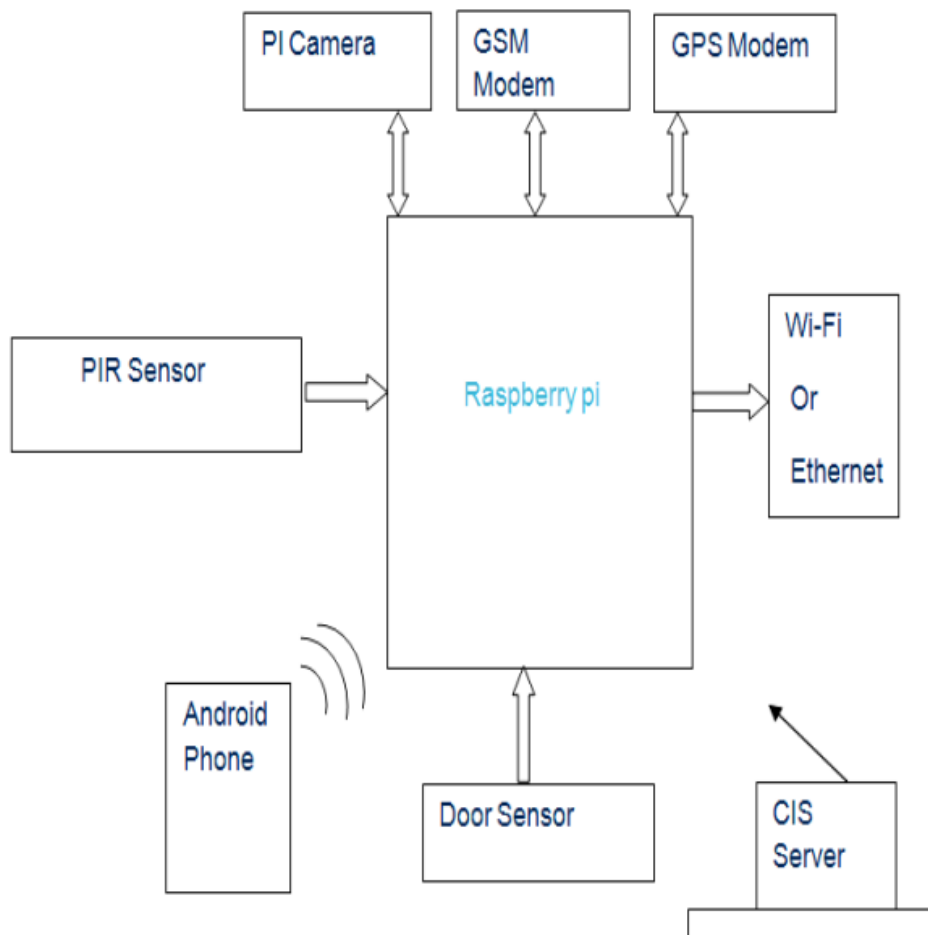

Fig. 4 Block Diagram of a Smart Automobile

At a predetermined interval, the Hotspot Connection is used to populate a mail to either the user's mail ID or the CIS (Centralized Image Server) mail ID contained in the Vehicle Interface. [15]

International Journal of Innovative Research in Science, Engineering and Technology

(An ISO 3297: 2007 Certified Organization)

Vol. 4, Issue 3, March 2015

V. CONCLUSION

Modern wireless technology and advances in radio analytics enable several cutting-edge Internet of Things (IoT) applications that will fundamentally alter our way of life and help us better comprehend what, when, where, and how the world around us works. Automobiles are multiplying in number and becoming increasingly automated, thus it's imperative that they be intelligent and offer driving assistance and safety assurances in this age of increased automation. Multipath propagation interacts with the driver and passengers within the automobile and records their features, which can be seen as a special case of rich scattering interior environments. Automated identification, monitoring, counting, and detection of an unattended/left child are all possible thanks to a pair of commercial Wi-Fi devices that are installed in a vehicle to provide Wi-Fi connection.

REFERENCES

1. Y. Wang, K. Wu, and L. M. Ni, "WiFall: Device-free fall detection by wireless networks," in Proc. Int. Conf. Comput. Commun., Apr. 2014, pp. 271–279.
2. Y. Zeng, P. H. Pathak, C. Xu, and P. Mohapatra, "Your AP knows how you move: Fine-grained device motion recognition through WiFi," in Proc. 1st ACM Workshop Hot Topics in Wireless, 2014, pp. 49–54.
3. Borgonovo, E.; Gatti, S.; Peccati, L. What drives value creation in investment projects? An application of sensitivity analysis to project finance transactions. Eur. J. Oper. Res. 2010, 205, 227–236
4. Weber RH. Internet of things-new security and privacy challenges. Comput Law Secur Rev. 2010;26(1):23–30.
5. Heer T, Garcia-Morchon O, Hummen R, Keoh SL, Kumar SS, Wehrle K. Security challenges in the IP based internet of things. WirelPersCommun. 2011;61(3):527–42.
6. Ahmed S. Salama, Bahaa K. Saleh & Mohamad M. Eassa (2010) "Intelligent Cross Road Traffic Management System (ICRTMS)", 2nd International Conference on Computer Technology and Development, pp27- 31
7. ManojKantaMainali& Shingo Mabu (2010) "Evolutionary Approach for the Traffic Volume Estimation of Road Sections", pp100- 105, IEEE.
8. Shilpa S. Chavan, Dr. R. S. Deshpande & J. G. Rana (2009) "Design of Intelligent Traffic Light Controller Using Embedded System" Second International Conference on Emerging Trends in Engineering and Technology, pp1086- 1091
9. Y. Wang, J. Liu, Y. Chen, M. Gruteser, J. Yang, and H. Liu, "E-eyes: Device-free location-oriented activity identification using fine-grained WiFi signatures," in Proc. 20th ACM Annu. Int. Conf. Mobile Comput. Netw., 2014, pp. 617–628.
10. J. G. Andrews, S. Buzzi, W. Choi, S. V. Hanly, A. Lozano, A. C. K. Soong, and J. C. Zhang, "What will 5G be?" IEEE J. Sel. Areas Commun., vol. 32, no. 6, pp. 1065–1082, Jun. 2014.
11. B. Wang, Y. Wu, F. Han, Y.-H. Yang, and K. J. R. Liu, "Green wireless communications: A time-reversal paradigm," IEEE J. Sel. Areas Commun., vol. 29, no. 8, pp. 1698–1710, Sep. 2011
12. ZigBee Alliance. Zigbee specification. Technical Report Document 053474r06, Version 1.0, ZigBee Alliance, June 2005.
13. Pereira C, Aguiar A. Towards efficient mobile M2M communications: survey and open challenges. Sensors. 2014;14(10):19582–608.
14. Qiu T, Xiao H, Zhou P. Framework and case studies of intelligent monitoring platform in facility agriculture ecosystem. In: Proc. 2013 second international conference on agro-geoinformatics (agro-geoinformatics), Fairfax, VA, USA, 12–16 Aug 2013. IEEE.