

Smart Security Systems

Gowtham S¹, Manas M Bhat², Himanshu Kumar³, Aneesh Seth⁴

Dept. of Mechanical Engineering, PES Institute of Technology South Campus, Bengaluru, India^{1,2,3,4}

ABSTRACT: Don't take your loved one's security for granted. If you think you don't need a security system to protect your loved ones, think again. Unfortunately, the facts about thefts and other security issues speak for themselves. In recent years, burglaries have increased by 9.8% from 2006. By adopting our type of security system, we help in detection of the burglar with our sophisticated method, wherein prevention of robbery is difficult (like in an ATM, where it is a secluded and private location). Consider an environment in which prevention of burglary is literally impossible (for example : an unoccupied house, an ATM, etc). The burglar entering such an isolated location would have a communication device like a cell phone, etc. In the case of our type of security system, it involves placing a signal sensor in a disguised location (for example: signal sensor placed in the camera of an ATM). Since each cell phone has a unique code, it emits unique radiations. This radiation will be recorded by the signal sensor placed within desired range. This recorded signal will be sent to the telecommunication base wherein the identity of the burglar will be revealed. Thus, enabling the law enforcement agencies to restore safety and security to citizens. Advantages of our type of security system: cheap, effective, has wide range of applications in private locations, no malfunctions.

KEYWORDS: mobile phone radiation, security, sensors, telecommunication base, theft.

I. INTRODUCTION

For nearly three quarters of a century, Indians have taken social security for granted. Basically, security is the degree of resistance to, or protection from, harm. It applies to vulnerable and valuable asset such as a person, dwelling, community, nation or organization. Security provides "A form of protection where a separation is created between assets and threats".[1]

The most breached type of security is home security. Home security is applicable to all of us and involves protection of all registered assets of the dwelling individuals. However, in today's world, there is an alarming increase in burglary and theft. Unfortunately, the facts about thefts and security issues speak for themselves. Of the total crimes committed in India, about 1.635 million are cognizable crimes under IPC (including theft, burglary, robbery, dacoity, riot, breach of trust), out of which 26% are property crimes (theft, burglary, robbery). Of the total IPC crimes, about half (50.6%) are committed in five states of Uttar Pradesh (12.7%), Madhya Pradesh (11%), Maharashtra (10.4%), Bihar (9.1%) and Rajasthan (7.4%). Karnataka ranks 7th in crime with 6.4%.

Some jaw dropping facts about burglary: Every 13 seconds, a home intrusion is committed. One out of three residential assaults is a result of burglary. Only 17% of homes have security system.[2] These facts are a wakeup call for the Indian Society. The real question is "What are you doing to protect your loved ones?". However, there are various types of security in today's world. Some of them include home alarm systems, operation identification, etc. The burglary facts depicts theft is committed at secluded and private location (for example, an unoccupied house, an ATM, etc). So, we have developed a new type of security system wherein, we help in detecting the burglar's identity with our sophisticated method.

II. DETAIL EXPLANATION OF THE SECURITY SYSTEM

Consider an environment in which prevention of burglary is literally impossible (like an unoccupied location). The burglar entering such an isolated location would have a communication device like a cell phone.

International Journal of Innovative Research in Science, Engineering and Technology

(An ISO 3297: 2007 Certified Organization)

Vol. 4, Issue 10, October 2015

Every electronic device emits some type of radiation, otherwise they would not be functional. The radiation emitted by mobile phones is essential for their use. Cell phone emits radio frequency(RF) energy. The amount of radiation emitted by a cell phone is measured by its specific absorption rate (SAR value).[3]

The maximum power output from a mobile phone is regulated by the mobile phone standard and regulatory agencies in each country. In communication protocols used by mobile phones, often result in low frequency pulsing of the carrier signal.[4] Since cell phones emit radio frequency energy (radio waves) of form of non-ionizing radiation, we are able to detect the radiation with signal sensors.[5]

We place the signal sensor in a disguised location (For example: Signal sensor placed in camera of the ATM). The radiation of the cell phone is detected by a signal sensor called as cell sensor. It detects and measures the strength of radiation of communication devices like mobile phones, etc. It also measures the distance of the origin of the mobile radiation.

The signal which was detected and measured by the cell sensor is stored in a sensor node. A sensor node is a node in a sensor network that is capable of performing processing, gathering sensory information and connecting with other nodes in the network.

The main components of a sensory node are microcontroller, transceiver, external memory, power source, sensors.

A. CONTROLLER

The controller performs tasks, processes data and controls the functionality of the other components in the sensor node. Digital signal processes is chosen for wireless communication applications, as it is the modest. That is, simpler, easier to process modulation and signal processing tasks of actual sensing data is less complicated.

B. TRANSCIVER

A transceiver is a device comprising both the transmitter and the receiver which are combined and share common circuitry. Transceivers operating in ideal mode have power consumption equal to the power consumed in receiving mode.[6]

C. POWER SOURCE

A wireless sensor node is a popular solution when it is difficult to run a main supply to the sensor node. An important aspect in the development of a wireless sensor node is ensuring that there is always adequate energy available to power the system. The sensor node consumes power for sensing, communicating and data processing. Power is stored either in batteries or capacitors. Batteries, both rechargeable and non rechargeable are the main source of power supply for sensor nodes.

D. SENSOR

In our type of security system, we use cell sensor located in a disguised location, which of it is explained above.[7]

III. WORKING OF SENSOR NODES

Sensors detect radiation emitted and sends it to the analog and digital converter (ADC), which is processed on to the microcontroller which interacts between a transceiver and an external memory. The energy supplied to the microcontroller is by the power source (Batteries or capacitors) as in figure 1.

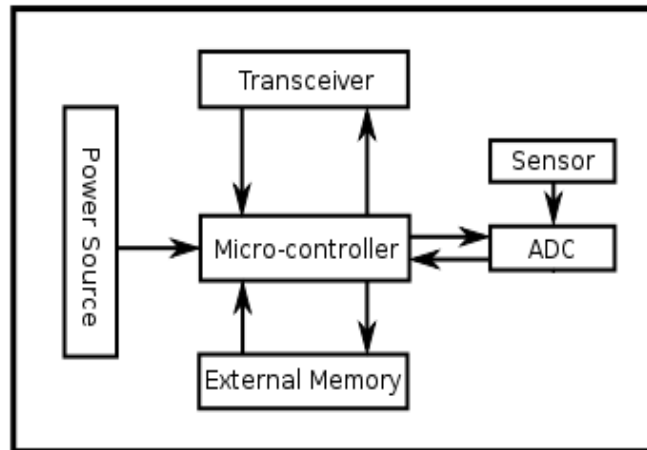

Figure 1

The recorded data by the sensor node is sent to the telecommunication base, wherein cross linking of mobile phone radiation is done with the existing data. The matching of the radiation will result in giving details of the user. Thus, identity of the burglar will be revealed (block diagram in figure 2).

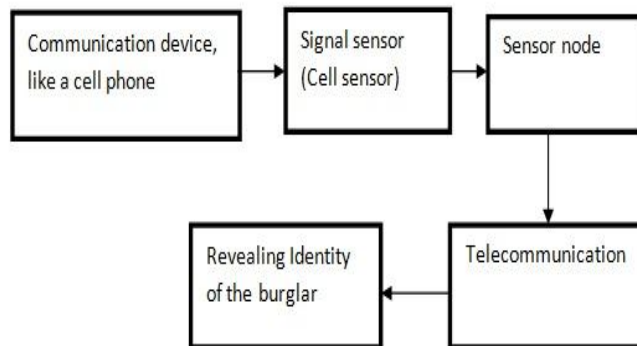

Figure 2

Example,

Consider an ATM wherein a person is alone. ATM room has dimensions 243cms x304.8cms. The burglar enters the ATM with the motive of committing a theft. Here, the person is defenseless. IN this case, the person and the burglar will have mobile phones. These mobile phones radiations will be detected by the cell sensor placed in the sensor of the camera. However, here there are two radiations detected as in figure 3.

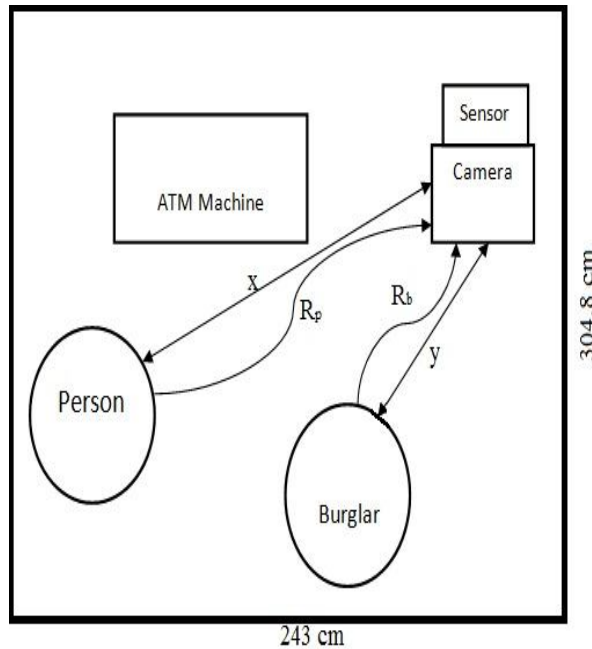

Figure 3

Here when investigation department reviews the case, the video which will be recorded will be viewed. The image will be captured by the camera when the signal sensor records this data. So, easily finding out who that burglar is and the person is by measured distances. Thus, easily the investigators will be able to detect the burglar when cross linked with the telecommunication base.

IV. PRICE

The cost of the entire security system is divided into three parts:

- i. Cell sensor, ranging upto Rs.3568.
- ii. Sensor node (Wi Sense, Wi Sense technologies), costing Rs.1327.[6]
- iii. Telecommunication base charge will approximately be Rs.500.

Thus, the entire security systems cost is going to be Rs.5395. However, number of existing security systems like “wireless GSM burglar intruder” will cost upto Rs.13000.

V. THEORETICAL EXPERIMENTATION

Governments have set a maximum exposure to mobile radiation expressed in milliwatts [mW (1mW/cm²)]. The sensor used will be a cell sensor, manufactured by Tech international of dimensions 13.0175cm x 6.35cm x 208575cm having a 9 volt battery. Radiation measurement is measured in two scales: 0-1 mW/cm² and 1-10 mW/cm². The sensor node used will be Wi sense(Wi Sense Technologies), having a data memory of 128 kB, program memory 56 kB and 4 kB RAM, thus having 188 kB of total memory. It uses 1.8V-3.6V. The dimension of a standard ATM is 243cmx304.8cm. Since mobile phone radiation is of the order 1 mW/cm²[8] and the sensor used has radiation scales of 0-1mW/cm², we can easily see the exact value of the radiation. This value of radiation will be stored within 128 kB allocated for the sensory node. Also, the image taken by the camera at the time of storing the value of radiation will be recorded within the allocated memory. These details will be later cross checked with the telecommunication base and the identity of the burglar will be revealed.



ISSN(Online) : 2319 -8753
ISSN (Print) : 2347 -6710

International Journal of Innovative Research in Science, Engineering and Technology

(An ISO 3297: 2007 Certified Organization)

Vol. 4, Issue 10, October 2015

VI. ADVANTAGES

- This type of security system is inexpensive and effective.
- The best advantage of this type of security system is it provides a sense of comfort.
- This security system malfunctions rarely.

VII. APPLICATIONS

- It has got wide range of applications in secluded and isolated location .
- In this, the sensors can be placed anywhere since they are wireless in nature.

CONCLUSION

Even though there exists different types of security systems in today's world, there's none that can catch the burglar once he has escaped from the place of robbery. Thus, we have provided an unique system in providing justice to the people and helping the law enforcement agencies with a cheaper and an effective method.

ACKNOWLEDGEMENT

We would like to thank our college for providing us a golden opportunity to exhibit our idea. We would also like to thank Professor Chandru for being instrumental in nurturing our idea and constantly guiding us in the right path.

REFERENCES

- [1] "ISECOM - Open Source Security Testing Methodology Manual (OSSTMM)". Retrieved 20 September 2014.
- [2] YourArticleLibrary.com, <http://www.yourarticlelibrary.com/crimes/characteristics-of-crime-in-india-with-statistics/43982/>
- [3] Computer Concepts: Illustrated Introductory
By Dan Oja, June Jamrich Parsons
- [4] "Output Power-Control Loop Design for GSM Mobile Phones" (pdf). Retrieved 12 February 2013.
- [5] Foster, Kenneth R.; Repacholi, Michael H. (2004). "Biological Effects of Radiofrequency Fields: Does Modulation Matter?". *Radiation Research* 162 (2): 219–25.doi:10.1667/RR3191 PMID 15387150S.
- [6] Wikipedia contributors. "List of wireless sensor nodes." Wikipedia, The Free Encyclopedia. Wikipedia, The Free Encyclopedia, 16 Sep. 2015. Web. 17 Sep. 2015.
- [7] Dynamic Power Management in Wireless Sensor Networks, Amit Sinha and Anantha Chandrakasan, IEEE Design & Test of Computers, Vol. 18, No. 2, March–April 2001.
- [8] Science Buddies Staff. (2015, May 5). Does Your Cell Phone Radiate? Measuring Cell Phone Electromagnetic Radiation. Retrieved September 16, 2015.