

# Ann Based Control Strategy for Parallel Operation of Single Phase Voltage Source Inverter

Sriram S<sup>1</sup>, Manikandan P<sup>2</sup>

Assistant Professor, Head of Department, Dept. of EEE, Sasurie College of Engineering, Tirupur, Tamilnadu, India<sup>1</sup>

Assistant Professor, Dept. of EEE, Sasurie College of Engineering, Tirupur, Tamilnadu, India<sup>2</sup>

**ABSTRACT:** This paper describes about the efficient control strategy in parallel operation of inverters in common alternating current (AC) bus which is used in real time applications like uninterrupted power supply (UPS), medical equipments and many. The control system for parallel operation of inverters consists of two main loops; the first control loop is parallelism control over the feedback inductor current to modify the input voltage to the filter. The second loop is voltage control over the output voltage of each individual voltage source inverter connected to the common AC bus. Here control system is implemented in neuro fuzzy control strategy which ensures less precise, flexible, better stability in control. The proposed control strategy ensures the voltage source inverters (VSI) operating in common AC bus with proper sharing of load current, redundancy and without any needs of communication exchange between inverter modules. The parallel operation of inverters in common AC bus with proposed control system are verified both in theoretical and experimental results.

**KEYWORDS:** Alternating Current (AC), Uninterrupted Power Supply (UPS), Voltage Source Inverters (VSI), Direct Current (DC), Average Load Sharing (ALS), Master Slave (MS)

## I. INTRODUCTION

The need for highly reliable power supplies has increased in recent years with the proliferation of critical loads such as computers, medical equipments, satellite systems, telecommunications, and other electronic dependent equipment, which are intensely in demand in present day society. Notwithstanding, the role of uninterruptible power supply (UPS) has also increased tremendously in sustaining high reliable power to those critical loads. One of the ways to achieve higher reliability is by paralleling two or more units of UPS. This is because the paralleled system has wide advantages over single unit UPS. Advantages include increase of power capability, enhanced availability from the fault tolerance with more than 1 module, and ease of maintenance with redundancy implementation [1]. In application for uninterrupted power supply (UPS) for very large application the parallel operation of inverters are seen in common AC bus. The parallel operation is a special feature of high performance uninterrupted power supply system. The parallel connection of UPS inverters is a challenging problem that is more complex than paralleling DC sources, since every inverter must share the load while staying synchronized. In theory, if the output voltage of every inverter has same amplitude, frequency, and phase, the current load could equally be distributed. However, due to interconnections. The first one is based on active load sharing techniques, and the major part of them is derived from control schemes of parallel-connected dc-dc converters, such as centralized master slave (MS) average load sharing (ALS), and circular chain control (3C). Although these control schemes achieve both good output-voltage regulation and equal current sharing, they need critical intercommunication lines among modules that could reduce the system reliability and expandability [2]. The parallel operation of voltage source inverters (VSIs) is a configuration that allows the processed load power to be shared among the converters, creating redundant systems and making the power expansion flexible. These characteristics have led to the use of this configuration in an uninterruptible power supply (UPS), mainly to build a redundancy

# International Journal of Innovative Research in Science, Engineering and Technology

(An ISO 3297: 2007 Certified Organization)

Vol. 4, Special Issue 13, December 2015

## II. THE CONCEPTION OF CONTROL STRATEGY

The control strategy includes two main loops for each voltage source inverters (VSI) connected to common AC bus. They are Parallelism control loop and voltage control loop. The parallelism control loop employs the feedback of the inductor current from the output filter to modify the input voltage of the same filter and, therefore, to control the power flow of each inverter to the load. The second loop voltage control is responsible for controlling the output voltage of the LC filter, which coincides with the output voltage

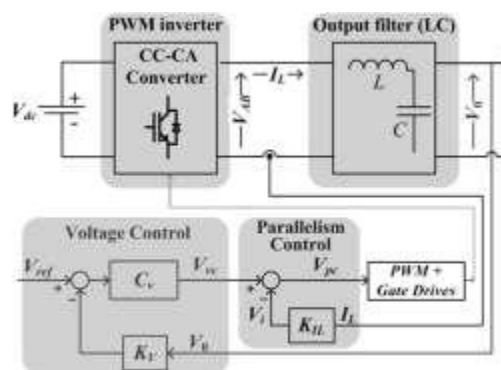

In each VSI, a control loop is added, called parallelism control, which is placed in cascade with the voltage controller  $C_v$ , as shown in Fig. 1. This second loop enables the inverter to work in parallel. This new control modifies the output signal of the voltage controller,  $V_{vc}$ , with the aim of changing the  $V_{pc}$  signal applied in the PWM modulator and, consequently, altering the  $V_{AB}$  voltage of the VSI. The parallelism control employs the feedback of inductor current  $L$  from the LC filter, called  $V_i$ , to modify the  $V_{vc}$  signal. Therefore, each VSI utilizes only the feedback of its own inductor current to ensure its proper parallel operation. A relevant point is that the proposed strategy is based on a single reference voltage ( $V_{ref}$ ) for all VSIs, thus the output voltages of all inverters have only small deviations, which are caused by parametric variations in the control and power Fig.1. Circuit of a VSI based on the proposed control strategy. Components of the inverters. Therefore, the parallelism control has the function of equalizing these small deviations to ensure power sharing among the inverters [3].

### Proposed Control Strategy

We consider a multi-input, single-output dynamic system whose states at any instant can be defined by  $n$  variables  $X_1, X_2, \dots, X_n$ . The control action that derives the system to a desired state can be described by a well known concept of if-then rules, where input variables are first transformed into their respective linguistic variables, also called fuzzification [4],[5]. Then, conjunction of these rules, called inferencing process, determines the linguistic value for the output. This linguistic value of the output also called fuzzified output is then converted to a crisp value by using defuzzification scheme. All rules in this architecture are evaluated in parallel to generate the final output fuzzy set, which is then defuzzified to get the crisp output value. The conjunction of fuzzified inputs is usually done by either min or product operation (we use product operation) and for generating the output max or sum operation is generally used. For defuzzification, we have used simplified reasoning method, also known as modified center of area method. For simplicity, triangular fuzzy sets will be used for both input and output. The whole working and analysis of fuzzy controller is dependent on the following constraints on fuzzification, defuzzification and the knowledge base of an FLC, which give a linear approximation of most FLC implementations [6].

**CONSTRAINT 1:** The fuzzification process uses the triangular membership function.

**CONSTRAINT 2:** The width of a fuzzy set extends to the peak value of each adjacent fuzzy set and vice versa. The sum of the membership values over the interval between two adjacent sets will be one. Therefore, the sum of all

# International Journal of Innovative Research in Science, Engineering and Technology

(An ISO 3297: 2007 Certified Organization)

Vol. 4, Special Issue 13, December 2015

membership values over the universe of discourse at any instant for a control variable will always be equal to one. This constraint is commonly referred to as fuzzy partitioning.

**CONSTRAINT 3:** The defuzzification method used is the modified center of area method. This method is similar to obtaining a weighted average of all possible output values.

An example of a very simple neuro fuzzy controller with just four rules is depicted in figure 2. This architecture can be readily understood as a —neural-like architecture. At the same time, it can be easily interpreted as a fuzzy logic controller. The modules X1 and X2 represent the input variables that describe the state of the system to be controlled. These modules deliver crisp input values to the respective membership modules (m-modules) which contain definitions of membership functions and basically fuzzify the input. Now, both the inputs are in the form of linguistic variables and membership associated with the respective linguistic variables. The m-modules are further connected to R-modules which represent the rule base of the controller, also known as the knowledge base. Each m-module gives to its connected R-modules, the membership value  $m(x_i)$  of the input variable  $X_i$  associated with that particular linguistic variable or the input fuzzy set. The R-modules use either min-operation or product-operation to generate conjunction of their respective inputs and pass this calculated value forward to one of n-modules. The n-modules basically represent the output fuzzy sets and store the definition of output linguistic variables. If there are more than two rules affecting one output variable then either their sum or the max is taken and the fuzzy set is either clipped or multiplied by that resultant value. These n-modules pass on the changed output fuzzy sets to C-module where the defuzzification process is used to get the final crisp value of the output.

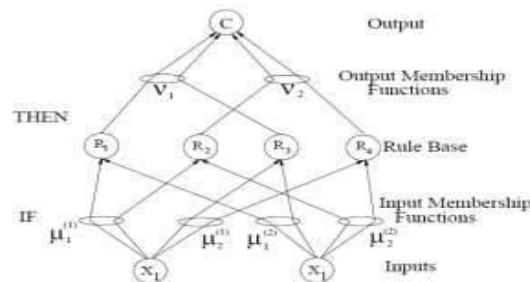

Fig 2. Architecture of four rule fuzzy controller from neural networks point of view. The X-, R-, and C-modules can be viewed as the neurons in a layered neural network and the n-units as the adaptable weights of the network. The X-module layer can easily be identified as the input layer of a multi-input neural network whereas the C-module layer can be seen as the output layer. The R-module layer serves as the hidden or intermediate layer that constitutes the internal representation of the network. The fact that one n-module can be connected to more than one R-module is equivalent to the connections in a neural network that share a common weight. This is of key importance for keeping the structural integrity of the fuzzy controller intact.

### III. EXPERIMENTAL ANALYSIS

The parallel operation of voltage source inverters connected in common AC bus used for much application like uninterrupted power supply and medical equipment sets. The output voltage of all inverters connected in common AC bus should be same and all should share the load equally. The AC source input is given to AC/DC converter and DC output is then fed into a single phase voltage source inverter and output is then filtered by a LC filter through isolation transformer between inverter and filter. The filter output is given to the common AC bus where similar AC output of other module is immersed. The output voltage from the output of filter is controlled by taking it as feedback and comparing with the reference voltage from reference voltage DC bus and controlled by classic PID control strategy in existing system and fuzzy logic control in proposed system. The error and change in error is analyzed in controller and current signal from the controller is given to parallelism control comparing with current to LC filter then signal is given to PWM gate driver circuit of inverter to vary switching of the inverter.

# International Journal of Innovative Research in Science, Engineering and Technology

(An ISO 3297: 2007 Certified Organization)

Vol. 4, Special Issue 13, December 2015

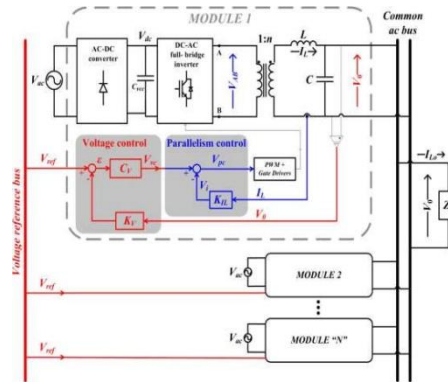

Fig 3. Circuit of VSIs modules connected in parallel

This methodology defines voltage and current equations for each inverter in relation to the components of all VSI. Thus, the model allows the study of the distribution of power, sharing, and circulation of currents among inverters in the case of parametric variation of the components, load variations, and controller modifications. The specification for two voltage source inverters connected in parallel in common AC bus shown in block representation in fig 3. are detailed in TABLE I

## IV. SIMULATION RESULTS

Pulse output after the process of control strategy from pulse width modulation (PWM) generator is shown in fig 4

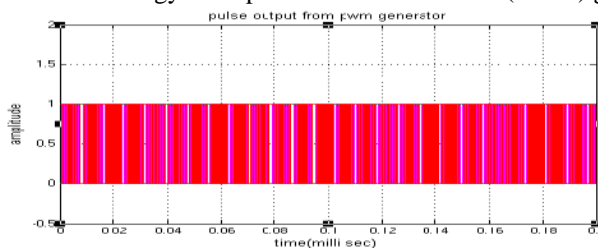

Fig 4 Pulse output from PWM generator

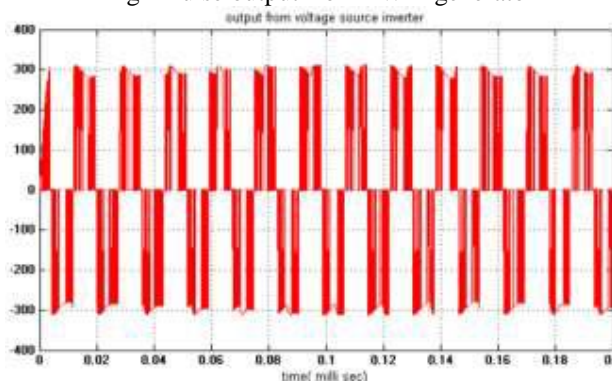

Fig 5 Square output voltage from inverter

The output current measured from voltage source inverter through isolation transformer is shown in fig 6

# International Journal of Innovative Research in Science, Engineering and Technology

(An ISO 3297: 2007 Certified Organization)

Vol. 4, Special Issue 13, December 2015

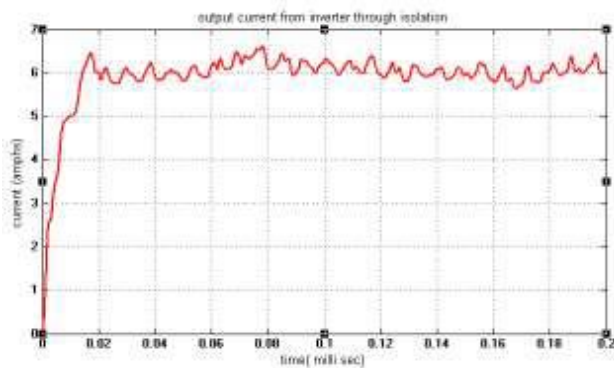

Fig 6. Output current measured from the inverter

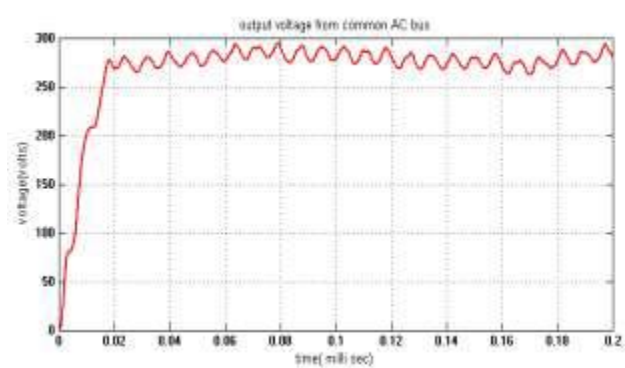

Fig 7. Output voltage measured from common AC bus

## V. CONCLUSION

Thus the uninterruptible power supplies (UPS) and medical equipments frequently needs parallel operation of inverters with proper loadsharing capability and redundancy. Hence proper control strategy should be implemented for independent operation of voltage sourceinverters making them to work at any load conditions and no load conditions. The control strategy allows the connection and/or disconnection of one inverter from the common ac bus with a smooth transient response in load voltage. It also enables the parallel operation of different power inverters. ANN control strategy which emerging control logic for many application is more efficient and satisfies all features of control strategies of parallel operation of voltage source inverters. Simulation results have shown that fast dynamic response, proper output regulation, and equal current distribution can be achieved in the proposed multi-module inverter system.

## REFERENCES

- [1] YeongJia.C and E. K. K. Sng, —A novel communication strategy for decentralized control of paralleled multi-invertersystems,| *IEEE Trans. Power Electron.*, vol. 21, no. 1, pp. 148–156, Jan. 2006.
- [2] Guerrero J.M, L. Hang, and J. Uceda, —Control of distributed uninterruptible power supply systems,| *IEEE Trans. Ind.Electron.*, vol. 55, no. 8, pp. 2845–2859, Aug. 2008.
- [3] Telles B. Lazzarin, *Member, IEEE*, Guilherme A. T. Bauer, and Ivo Barbi, —A Control Strategy for Parallel Operation of Single-Phase Voltage Source Inverters: Analysis, Design and Experimental Results| *IEEE transactions on industrial electronics*, vol. 60, no. 6, june 2013.
- [4] Comparison between Conventional PID and Fuzzy Logic Controller for Liquid Flow Control: Performance Evaluation of Fuzzy Logic and PID Controller by Using MATLAB/Simulink Gaurav, AmritKaur, june 2012
- [5] Zhongyi.H and X. Yan, —Distributed control for UPS modules in parallel operation with RMS voltage regulation,| *IEEE Trans. Ind. Electron.*, vol. 5, no. 8, pp. 2860–2869, Aug. 2008.
- [6] Qing-Chang Zhong, Senior Member, *IEEE*,| Robust Droop Controller for Accurate Proportional Load Sharing Among Inverters Operated in Parallel| *IEEE transactions on industrial electronics*, vol. 60, no. 4, april 2013
- [7] Pascual M, G. Garcera, E. Figueres, and F. Gonzalez-Espin, —Robust model-following control of parallel UPS single-phase inverters,| *IEEE Trans. Ind. Electron.*, vol. 55, no. 8, pp. 2870–2883, Aug 2008