

Osmotic Power from Solar Pond Power Plant: A New Suggestion towards Co-Generation

Drisy U¹, Sreelakshmi C S¹

Assistant Professor, Department of EEE, Ammini College of Engineering, Mankara, Palakkad, Kerala, India¹

Assistant Professor, Department of EEE, Ammini College of Engineering, Mankara, Palakkad, Kerala, India²

ABSTRACT: Green energy is considered a commendable effort in solving the world's increasing energy consumption, source of this being the renewable resources such as wind, solar radiations tidal waves etc. Rather going for single type energy generation hybrid power generation schemes and co-generation schemes are now-a-days widely accepted to meet increased power demands. Here, a new idea of co-generation is suggested which incorporates osmotic power generation and solar pond. A solar pond is a simple and low cost solar energy system which collects solar radiation and stores it as thermal energy for a relative longer period of time which can be converted to electrical energy by suitable conversion process. The heat blocking medium in the solar pond is salt water. This salt water after utilization is fed back to the pond during the feedback period it can be substituted as one of the source for osmotic power generation before reaching the pond. Osmotic power is a form of renewable energy which is currently not used at a commercial scale, but it might have the potential to be exploited in a sustainable manner in the near future. It uses the principle of osmosis which is used since recent years for several membrane applications like desalination and filtration. The salinity gradient between fresh water and salt water, separated by a membrane, causes an osmotic flow which can be converted into electricity. In this work these two types of power generation methods with common source are brought together to increase net-generation in a cost effective way.

KEYWORDS: Solar pond, Osmotic power, RED,PRO, OMU, Co-generation

I. INTRODUCTION

Our world is facing Demand-Supply energy gap. So there is a need for a reliable and cost effective solution to the present energy crisis. Green energy is the solution for this problem. Green energy comes from natural sources such as sunlight, wind, rain, tides, plants, algae and geothermal heat. These energy resources are renewable, meaning they are naturally replenished. In contrast, fossil fuels are a finite resource that take millions of years to develop and will continue to diminish with use. So the generation and utilization of green energy has to be promoted in order to overcome the energy crisis existing now and to protect the nature balance by controlling the over exploitation of non-renewable resources. The generation of power from renewable energy resources are quite costly compared conventional power generation schemes for the same output. Also availability of renewable energy resources may be influenced by seasonal changes and weather conditions. This problem brought out the ideas of hybrid power generation and co-generation. In hybrid power generation schemes output of different power generation units are combined to meet the demand rather than depending on a single generation source. The combination can be conventional and renewable power generation schemes and also can be renewable power generation schemes alone. Co-generation is defined as the sequential generation of two different forms of useful energy from a single primary energy source. It provides a wide range of technologies for application in various domains of economic activities. The overall efficiency of energy use in cogeneration mode can be increased. Improved efficiency of a system can be achieved by co-generation [1]. Co-generation mainly concentrates on power generation from the wasted energy. It utilizes the waste energy in the form of heat, pressure etc from different power plants to generate power which ultimately increases the output of the main power plant. In this paper a new idea of Co-generation process is suggested where power is generated by the process of osmosis by using the salt water in the solar pond.

II. SOLAR POND

Solar pond is a natural or artificial body of water for collecting and absorbing solar radiation energy and storing it as heat. It is a mass of shallow water about 1 or 2 meters deep with a large collection area, which act as heat trap. It contains dissolved salts to generate stable density gradient. In the salt gradient solar pond, dissolved salt is used to create layer of water with different densities. The salt concentration steadily increases with depth until at the bottom where the salt gradient is high. Fig.1 shows the schematic diagram of a solar pond power plant. Extraction of thermal energy stored in the lower layers of the pond can be easily accomplished without disturbing the non-convective salt gradient zone above. Hot brine can be extracted from solar pond without disturbing the concentration gradient. Hot brine can be withdrawn and cool brine returned in a laminar flow pattern because of presence of density gradient. Thermal energy from solar pond is used to drive Rankine cycle heat engine. Hot water from the bottom level of the pond is pumped to evaporator where the organic working fluid is vaporized the vapour flows under high pressure to turbine and there by expanding through the turbine. And the generator linked to it. The vapour then travels to condenser where cold water condenses the vapour back to evaporator and the cycle is repeated. [2] The temperature difference created between the top and the bottom of the solar ponds can be as high as 40–60°C. [3] The collected and stored heat can be extracted and used for industrial process heat, space heating, etc. The working temperature of a solar pond is 70 – 90° C. For collecting this heat a salt concentration of atleast 27% is maintained [4]. Generally the efficiency can be noted as 17 %. The low efficiency of solar pond is usually justified with the argument that the ‘collector’ being just a plastic-lined pond, might potentially result in a large scale system that is of lower overall levelised energy cost than a solar concentrating system. [5]. There is no exact method available for sizing a solar pond depending on the heating requirements. [6]

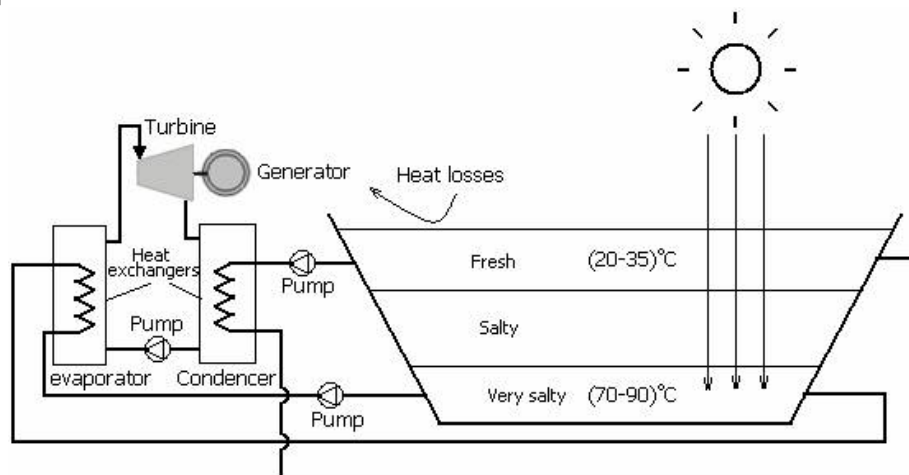

Fig.1 Schematic diagram of solar pond power plant

Solar pond power plants are attractive for the following reasons:

- They are easy to build.
- A pond has built-in storage in the large mass of salt water.
- Ponds clean themselves up. By contrast, glass solar collectors must be cleaned regularly to maintain performance.
- By using very little metal or plastics, solar pond operations help conserve materials.
- Solar ponds use local resources and do not pollute the environment. The temperature increase in the pond is well within that found in hot springs and geysers. [3]

Some of the solar pond are installations are at BeitHaArava pond built in Israel, Bhuj Gujarat and Texas in U.S. A 6000 m² solar pond has been constructed at Bhuj, Kutch in a milk-processing dairy which is shown in Fig.2. It has an achieved design capacity of supplying 80,000 litres of hot water per day to the dairy at 70°C or above. It is designed to supply about 22,000,000 kWh of Thermal Energy annually. The project, with a total outlay of Rs.8.73 million, sponsored by the Ministry of Non-conventional Energy Sources as a National Project, was a joint venture among Tata Energy Research Institute, Gujarat Energy Development Agency and Gujarat Dairy Development Corporation Ltd. A

major portion of industrial energy consumption is in the form of thermal energy. Solar pond technology is an alternative that offers various cost-effective end-uses without endangering the environment.



Fig.2 Solar pond at Bhuj

For a particular location to be appropriate for a solar pond, there are several essential requirements that must be satisfied.

- Use for the heat or power produced
- Access to water
- Access to salt
- Disposal method for surface brine removed

In addition to the stated essential requirements, there are desirable characteristics for solar pond site, most of which are obvious

- High insolation
- Moving water table not too close
- Low wind speed
- Absence of Wind-borne debris
- Relatively flat site
- Soil with good cohesion for walls [7]

Thus the advantages and disadvantages of solar pond may be listed out as

- The approach is particularly attractive for rural areas in developing countries. Very large area collectors can be set up for just the cost of the clay or plastic pond liner.
- The accumulating salt crystals have to be removed and can be both a valuable by-product and a maintenance expense.
- No need for a separate collector for this thermal storage system.
- The extremely large thermal mass means power is generated night and day.
- Relatively low-temperature operation means solar energy conversion is typically less than 2%.
- Due to evaporation non-saline water is constantly required to maintain salinity gradients.

III. POWER GENERATION BY OSMOSIS

It has been known for centuries that mixing freshwater and seawater releases energy. Salinity-gradient energy is the energy released when waters with different salt concentrations are mixed together. This energy can be easily encountered at the interface between waters of differing salt concentrations, for instance where rivers meet the ocean. This energy can be retrieved using the process called Osmosis. Osmotic Power plant generates electrical energy utilizing the energy outcome of mixing water with different salt gradients. The general diagram of osmotic power plant is shown in Fig.3. The flow of solvent from dilute solution to the concentrated solution across the semi permeable membrane is due to osmosis [7]. In the case of osmotic process there are three parts mainly two solutions and one semi

permeable membrane. Solutions are fresh water and salt water. A semi permeable membrane, which is an organic filter, separates the solutions. The flow of solvent from its side to solution side across a semi permeable membrane can be stopped if some extra pressure is applied to solution. This pressure that just stops the flow of solvent is called osmotic pressure. The membrane only lets small molecules like water-molecules pass. The water aspires to decrease the salt-concentration on the side of the membrane that contains most salt. The water therefore streams through the membrane and creates a pressure on the other side. This pressure can be utilised in order to gain energy, for example by using a turbine and a generator. [8]

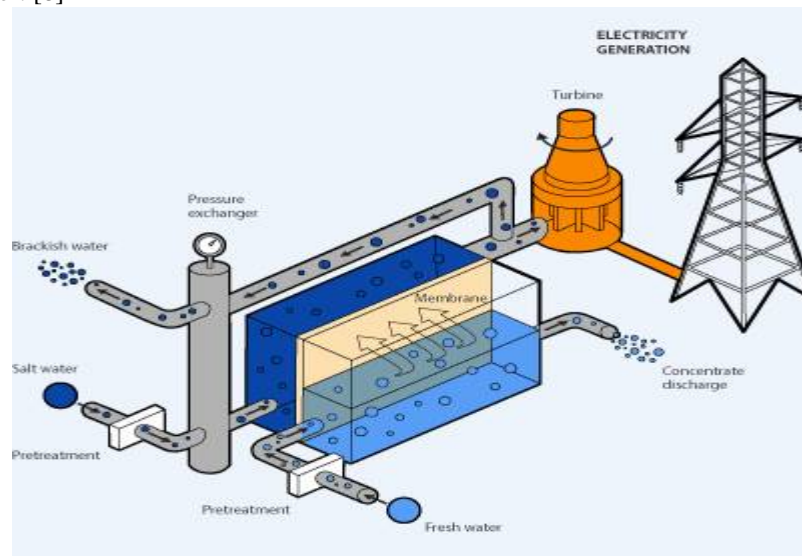

Fig. 3 General schematic diagram of an osmotic power plant

Two practical methods for the osmosis power generation are Reverse electro dialysis (RED) and Pressure retarded osmosis (PRO). In this paper PRO technique is used for osmotic power generation.

Pressure retarded osmosis (PRO) is a technique as shown in Fig.4 to separate a solvent (Fresh water) from a solution that is more concentrated (Sea water) and also pressurised. A semipermeable membrane allows the solvent to pass to the concentrated solution side by osmosis. The technique can be used to generate power from the salinity gradient energy resulting from the difference in the salt concentration between sea and river side. In this method, sea water is pumped into a pressure chamber that is at the pressure lower than the difference between the pressures of saline water and fresh water. Fresh water is also pumped into the pressure chamber through membrane, which increases both volume and pressure of the chamber. As the pressure differences are compensated, a turbine spins, and provides kinetic energy. This pressure can be in the range of 24 to 26 bars depending on the salt concentration of seawater [9]. The salt concentration is generally maintained as 3.5% or more as osmotic pressure increases with salt concentration [7][10].

This type of power generation is very reliable, less moving parts than a conventional hydroelectric project. It is very quiet when operating and requires minimal supervision. The expected life time of this plant is very large. The installed osmotic power plant could be run for many years cost effectively.

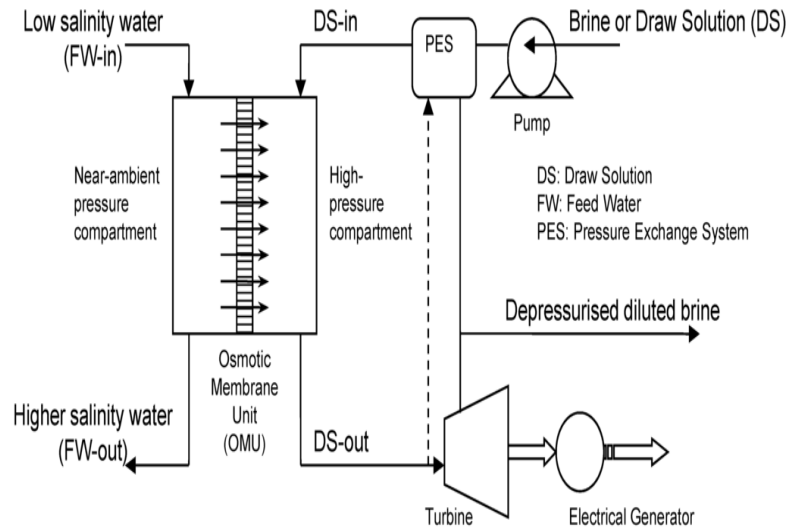

Fig.4 Flow diagram of osmotic power plant

While highly reliable, simple and cheap to run and maintain, this plant is very expensive to install. The permeable membrane is an expensive source and to have meaningful output, a very large membrane area is required. PRO can achieve efficiencies in the range 54- 56% [11]. PRO type Osmotic power plant is located at Norway which is shown in Fig.5. Its production capacity is 25 MW.



Fig 4 Osmotic power plant at Norway

Advantages:

- The energy produced is clean and non-polluting.
- There is no carbon dioxide or any other byproducts released. It produces no greenhouse gases or other waste.
- It is a renewable energy that will help reduce our reliance on the burning of fossil fuels.
- So the electricity supply is constant and efficient.
- Once you've built it, the energy is free because it comes from the ocean's power
- It needs no fuel.
- It produces electricity reliably.
- Not expensive to maintain.
- A plant is expected to be in production for 75 to 100 years
- Uses an abundant, inexpensive fuel source (water) to generate power

Disadvantages:

- You will need to find a way to connect the electricity to the grid.
- The average salinity inside the basin decreases, also affecting the ecosystem
- A barrage across an estuary is very expensive to build, and affects a very wide area - the environment is changed for many miles upstream and downstream.
- Many birds rely on the tide uncovering the mud flats so that they can feed. Barrage systems require salt resistant parts and lots of maintenance
- Effects on marine life during construction phases.
- Operation and control must be provided remotely and maintenance is complicated due to sea-basing of the generation facilities.
- Expensive to construct

IV. OSMOTIC POWER FROM SOLAR POND

The salt water and fresh water are two main requirements in solar pond and osmotic power plant. In the co-generation scheme suggested in this paper these two power generation methods are arranged together so that a combined output can be obtained from same source. The limitation of osmotic power is that its generation location is where river empties to sea or ocean and that will be away from the load centres. So transmission of power is difficult. If salt water availability can be assured, the location of osmotic power plant can be shifted considering fresh water availability only. Now if the salt water source is solar pond it becomes the solution to that problem. The salt water concentration in solar pond is greater comparing to sea or ocean that the resulting osmotic pressure created by solar pond will be high. The other advantage of this method is that there will be proper disposal of brine from the osmotic power plant. The brine solution if fed back to solar pond. Now in the solar pond power plant, the output of the evaporator is fed back to the pond for further heating. This salt water available from the evaporator instead of feeding back can be used as one of the source for osmotic power plant, the other source being fresh water. Thus the total output power from the solar pond power plant can be increased and also this makes possible the installation of osmotic power plant away from the river mouth near to the load centres.

V. DESIGN OF SUGGESTED CO-GENERATION SYSTEM

The proposed design of co-generation system, by combining the solar pond and osmotic power generation is shown in Fig.6. In the normal process the salt water in the pond gets heated by solar radiation. The hot salt water from the bottom layer of the pond is drained to the evaporator for vaporizing the organic fluid. The salt water output of the evaporator will have very low temperature but same salt gradient. In the modified system this salt water instead of feeding back to the pond can be temporarily stored in a tank so that inflow to the osmotic power plant can be in a controlled way. This salt water or brine solution is then fed to the high pressure compartment of the osmotic membrane unit (OMU). The fresh water is fed to the other side of the pressure compartment. Here by the process of osmosis high pressure brine solution is created which is used to rotate the turbine. Now the salt water output of the turbine and the high pressure compartment is collected and fed to diluted brine storage tank and from there discharged to the bottom layer of the pond so that the density gradient of each layer remains unaffected. The diluted brine storage tank is used to maintain the water level in the pond. By doing this the output of the co-generation plant increases as now total output is the sum of outputs of these individual power plants. This co-generation system has the main advantages that the resources are less costly and they are common to both plants except the semi permeable membrane. The solar pond Salt gradient is 20 – 30% which can create effective osmotic pressure as salt gradient of fresh water is near to zero. Researches are on progress to design less cost efficient semi permeable membrane. The salt water can be made artificially and the only constraint left now is the availability of fresh water, which can be solved by finding the site of installation nearer to fresh water resources. This system will not create any disturbance to ecosystem as no salt water discharge is released to the surrounding habitats. The co-generation scheme has another advantage that even when solar pond faces adverse climatic conditions such as wind, less radiation etc the net output of the system is not zero as there will be always osmotic power generation. Size constraints of the co-generation plant is not discussed in this work as it depends on the power requirement, land availability etc. Also the initial cost will be high for pond formation and osmotic power plant installation.

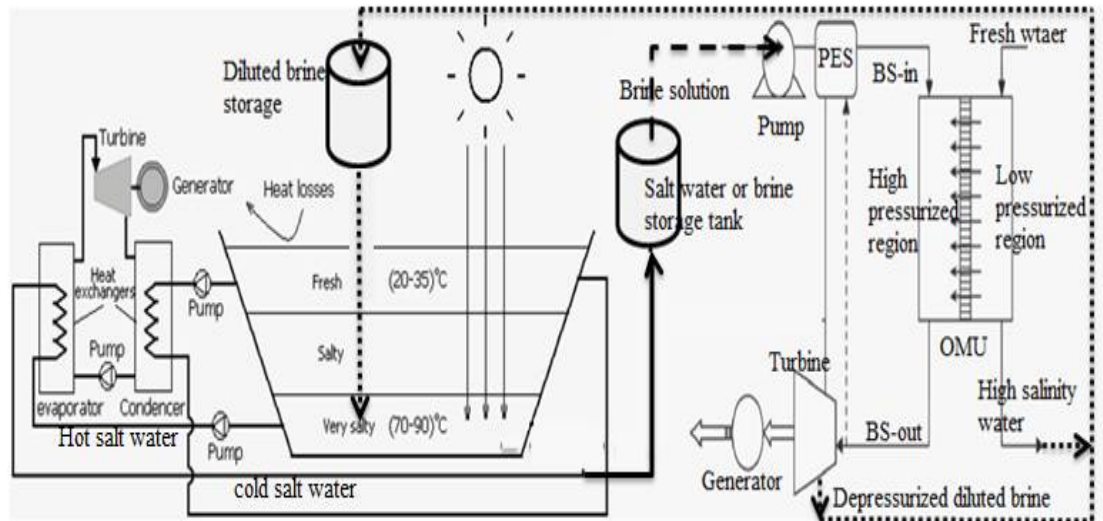

Fig. 6 Schematic diagram of Co-generation plant

VI. CONCLUSION

At present, the global energy supply is largely based on oil, natural gas and coal. The global reserves on these fossil fuels are finite and the link between global energy consumption and environmental problems such as climate change are widely acknowledged. Because of the environmental problems and the fact that the mining of fossil fuels becomes increasingly expensive, alternative methods have been developed to gain energy for eg nuclear power. But this alternative is under a severe public debate that it is a threat to humanity and the environment. Another alternative is to gain energy from renewable energy sources. Though humans have been using most of these sources for thousands of years, so far only a tiny fraction of the technical and economic potential of renewable has been captured and exploited. A comparatively cost effective way of renewable energy generation is suggested in this paper which is the output of a co-generation system. Here the proposed system consists of two types of power plants solar pond and osmotic power plant is coordinated together to work under a common source, salt water. Of these two types osmotic power plant was found bit more costly mainly due to the semi permeable membrane. But during the last decades, the membrane technology has increasingly improved. The improving membrane characteristics have ensured a growing membrane market which resulted in a decrease in membrane price which very soon will lead to easy access of membranes. Other problem faced by the osmotic power plant is that it is situated near the river mouth for the easy availability of salt and fresh water and so the transmission of power to the urban areas is difficult. This problem is solved to a great extent in this co-generation system as salt water is readily available from the solar pond.

Any waste land can be made the site for co-generation plant under given condition that fresh water availability is ensured. The power output from the co-generation plant is expected to be sufficient for small scale power supply i.e., enough for the power supply to a rural area. Even though large scale production of power is not ensured establishing such small scale power generating units will be a relief to the large scale generating units from power demand pressures.

REFERENCES

- [1] Buero of energy efficiency "Co generation", guide for energy engineers pp 1-18
- [2] G.D . Ray , "Non -Conventional Sources of energy" pp- 138-148, Fourth edition , 2010
- [3] Yehuda.L->Bronicki,"A solar power plant", IEEE spectrum February 1981
- [4] S P Shekhawat, N V Halegowda, M Husain "Salt Gradient Solar Pond: Future Energy Option for India", International Journal of Energy Engineering (IJEE), Feb. 2014, Vol. 4 Iss. 1, PP. 9-11
- [5] Yehuda L. BronickiA, " solar pond power plant", IEEE spectrum FEBRUARY 1981
- [6] Sathish D , Sathish Kumar T R "Effective Study On Solar Pond And Its Various Performances", 3rd International Conference on Innovative Research in Engineering and Technology (iCIRET2015), April 9-11, 2015

International Journal of Innovative Research in Science, Engineering and Technology

An ISO 3297: 2007 Certified Organization

Volume 5, Special Issue 5, April 2016

International Conference on Emerging Trends in Smart Grid Technology - INCETS'16

Organized by

Dept. of EEE, College of Engineering, Trikaripur (CAPE, Government of Kerala), Cheemeni, Kasaragod, Kerala-671313, India

- [7] Dineshkumar U. Adokar¹ , Dhanesh S. Patil² , Amrita Gupta, "Generation of electricity by osmosis" ,International Journal of Emerging Technology and Advanced Engineering, Volume 3, Issue 3, March 2013
- [8] O.Alverz –Silva ,A.Osario, S.Ortega , "Estimation of the Electric Power Potential Using Pressure Retarded Osmosis in the Leon River's Mouth: A First Step for the Harnessing of Saline Gradients in Colombia
- [9] Stein Erik Skilhagen, "Osmotic Power –a new renewable energy source" December 2009
- [10] Fernanda Helfer, Charles Lemckert, Yuri G. Anissimov "Osmotic Power with Pressure Retarded Osmosis: Theory, Performance and Trends – a Review"
- [11] Karakavalasa Goutham, Chukka Siva Krishna "Solar Pond Technology", International Journal of Engineering Research and General Science Volume 1, Issue 2, December 2013