

Comparison on the Effect Of Regenerative and Sub Cooling in the Heat Transfer Characteristics of Semi Cryogenic Thrust Chamber Having Rectangular Cooling Channels by Using CFD and Numerical Analysis

Sarath Raj¹, AswaniRajan²

Assistant Professor, Dept. of Mechanical Engineering, Sree Narayana Institute of Technology, Kerala India¹

Assistant Professor, Dept. of Electrical and Electronics Engineering, Sree Narayana Institute of Technology, Kerala, India²

ABSTRACT:In this paper, Computational Fluid Dynamics and Numerical Analysis is used to investigate the rocket thrust chamber cooling characteristics. The scope of the investigation involves the study of effect of regenerative and sub cooling on the heat transfer characteristics of coolant channel. Steady state pressure based analysis is carried out in this work. The temperature distributions of coolant along the rectangular cooling channel, temperature distributions of copper and stainless steel walls are the main focus of the study. In this study the, the coolant (kerosene), which is the fuel) enters at the aft end of the thrust chamber and passes through the rectangular cooling channels before it is fed to the injectors.

KEYWORDS:Computational Fluid Dynamics, Numerical Analysis, Thrust Chamber, Rectangular Cooling Channel.

I. INTRODUCTION

All rocket engines have one problem in common; high energy released by combusted gases. This problem results in high combustion temperatures in the order of 2400K to 3600 K, high heat transfer rates (0.8 to160 MW/m²) in thrust chamber and therefore requires special cooling techniques for the engine. Cooling techniques developed to cope with this problem, either singly or in combination, include regenerative, radiation, sub cooling, film cooling or transpiration cooling, ablation, arid inert or endothermic heat sinks. To choose the proper cooling technique mission requirements, environmental requirements and operational requirements should be considered. Regenerative cooling is one of the most widely applied cooling techniques used in liquid propellant rocket engines.

In this paper CFD modelling and analysis is used for predicting the heat transfer characteristics, considering a rectangular channel of aspect ratio 5.Numerical analysis is also carried along with the CFD analysis. Regenerative cooling of a liquid propellant rocket engine consists of a balance between the energy rejected by the combustion of gases and the heat energy absorbed by the coolant. The energy absorbed by the coolant is not wasted; it increases the initial energy content of the propellant prior to injection, increasing the exhaust velocity slightly (0.1 to 1.5%). Therefore thermal energy is recovered in the system. Basically there are three domains in a generatively cooled rocket engine; gas domain (combusted gases), liquid domain (coolant) and the solid domain (thrust chamber wall). Among all the different cooling systems the regenerative is the most efficient along with film cooling. In regenerative cooling, the fluid flows in cooling channels surrounding the thrust chamber; as a consequence the study of flow evolution in the channels becomes important in the case thrust chamber thermal design and for the system analysis, particularly in the case of closed-cycle turbo pump-fed engines. In the cooling channels the propellant can be either in a subcritical or supercritical state depending on its nature and on its thermo dynamical state.

International Journal of Innovative Research in Science, Engineering and Technology

(A High Impact Factor, Monthly Peer Reviewed Journal)

Vol. 5, Issue 1, Januray 2016

II. LITERATURE REVIEW

Mary F. Wadel[1] did an analytical investigation on the effect of high aspect ratiocooling channels, by considering different channel designs, on hot-gas-side wall temperature and coolant pressure drop for liquid hydrogen cooled rocket combustion chamber. Coolant channel design element considered were; length of combustion chamber in which high aspect ratio (height/width) cooling was applied, number of coolant channels. And coolant channel shape. Daniel K. Parris and D. Brian Landrum[2] determined the flow field characteristics in a coolant channels by the use of a commercial CFD and metaphysics software developed by CFD Research Crop called CFD-ACE+. The channels are characterized by high Reynolds number, varying aspect ratio, varying curvature, asymmetric and symmetric heating. The supercritical hydrogen is used as coolant for their analysis. Micheal L. Meyer[3] conducted an experiment on a series of electrically heated tube to investigate the effect of high aspect ratio on the curvature heat transfer enhancement in uniformly heated rectangular cooling passages. Three hardware geometry were tested; a base line straight aspect ratio 10 tube, an aspect ratio 1 (square) tube with 45o curve, and an aspect ratio 10 tube with a 450 curve. Gaseous nitrogen is used as coolant. C. L. Mercle, D. Li, and V. Sankaran[4] discussed the use of detailed CFD modelling for the description of cooling in rocket chambers. The overall analysis includes a complete three-dimensional analysis of the flow in the regeneratively cooled passages, conjugate heat transfer in the combustor wall, and the effect of film cooling on the inside chamber. Representative results for the cooling passages are presents showing the effect of heat conduction in the copper walls with tube aspect ratio of 1.5:1.

III. PROBLEM SOLVING WITH CFD

In solving fluid flow problems we must be aware that the underlying physics is complex and the results generated by a CFD code are at the best as good as the physics and chemistry embedded in it and at worst as its operator. Prior to setting up and running a simulation using CFD software there is a stage of identification and formulation of the problem in terms of its physical and chemical phenomena that need to be considered. Over 50% of time spent in industry on a CFD project is devoted for defining the domain geometry and for grid generation.

IV. COMPUTATIONAL FLUID DYNAMICS SIMULATION

The design, scalability, and running of unit operations in chemical process industries rely heavily upon empiricism and correlations of overall variables for non-ideal or non-equilibrium conditions. Many equipment designs in use are based on the past experience of experts applying rules of thumb, resembling art more than science. Processes that are sensitive to the local phenomena and the reactant concentrations are often difficult to design or scale up, because the design correlations do not take local effects into account. Non-idealities introduced by scaling up of lab or pilot scale equipment are difficult, if not impossible to predict accurately.

Researchers, equipment designers and chemical process engineers are increasingly using computational fluid dynamics (CFD) for analysing the flow and performance of process equipments, such as chemical reactors, stirred tanks, fluidized beds, cyclones, spray dryers, pipeline arrays, combustion systems, heat exchangers and other equipments. CFD allows for in depth analysis of the fluid mechanics, local effects, and chemistry in these types of equipment such as turbulence and combustion. CFD can be used when design correlations or experimental data are not available. It provides comprehensive data that are not easily obtainable from experimental tests. It highlights the root cause, not just the effect and many 'what if' scenarios can often be analysed in a short time. This method reduces scale-up problems, because the models are based on the fundamental physics and are scale-independent. CFD is basically the science of predicting heat transfer, fluid flow, chemical reactions, mass transfer and related phenomena by solving the mathematical equations that govern these processes using numerical algorithm. It is the merger of the classical branches of theoretical and experimental science, with the infusion of modern element of numerical computation. The results of CFD analyses are relevant engineering data used in conceptual studies of new designs, product development, and redesign. In many cases, CFD results in better insight, better reliability, improved performance, more confident scale-up, improved product consistency, and higher plant productivity. The progress of CFD during the last fifty years has been extraordinary. Much of this progress has been driven by the outstanding increases in digital computing speed. The continual and exponential increase in computing power, also improved the physical models in many CFD codes,

International Journal of Innovative Research in Science, Engineering and Technology

(A High Impact Factor, Monthly Peer Reviewed Journal)

Vol. 5, Issue 1, Januray 2016

and better user interfaces now enables non-experts to use CFD as a design tool on day-to-day basis. As a consequence, CFD has progressed from the domain of mainframe to the high-end engineering workstation and even to laptop PCs.

V. MODELLING

For aspect ratio 5 channel dimensions are height of the channel is 3mm, width 0.6mm and rib width is 2.3mm.

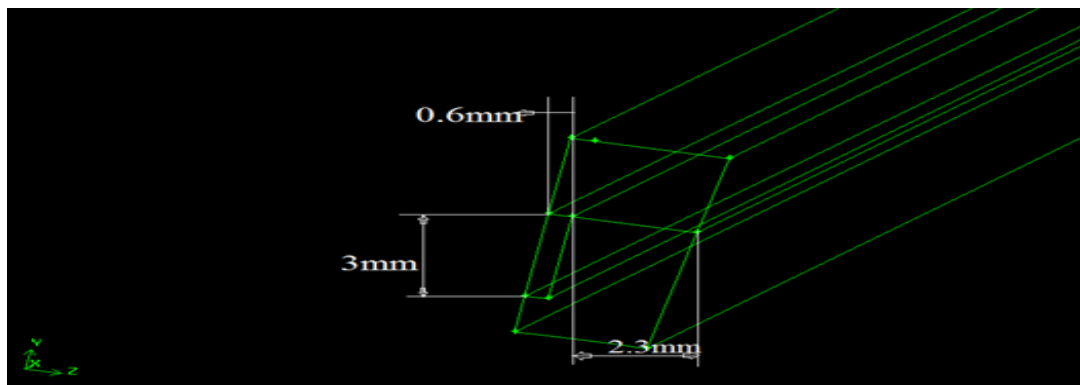

Fig. 1. Channel dimensions.

VI. GRID GENERATOR

GAMBIT 2.4.6 is used for modelling and grid generation. FLUENT 6.3.26, a pressure based segregated solver, is used for the analysis. Standard k- ϵ two-equation turbulence model is employed with standard wall functions. SIMPLE algorithm is used to get the pressure field. The computational domain consists of one fluid and two solid domains. The fluid domains include coolant (kerosene) which flows through the rectangular channels provided on the surface. The solid domains include inner copper shell and stainless steel outer covering.

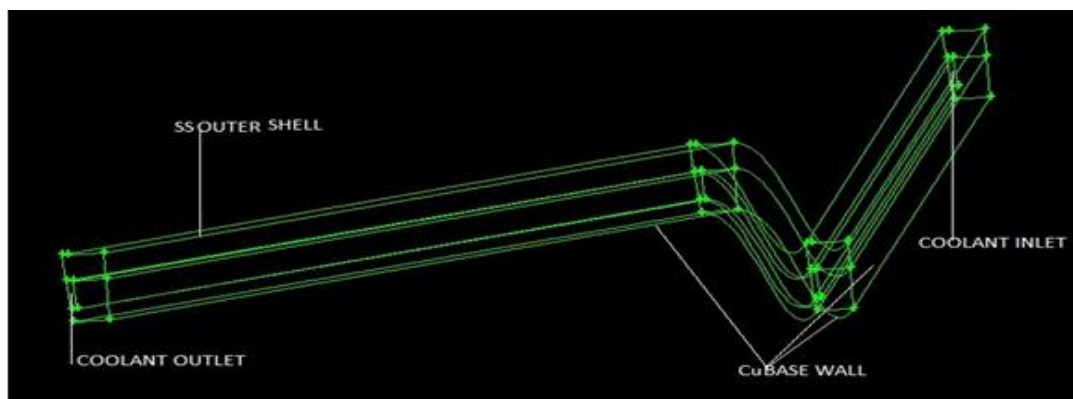

Fig. 2. Selected sectors with boundary conditions

Comparatively fine structured mesh is adapted for the geometry. Tet/Hybrid elements of TGrid type is used for the volume mesh and for the entire computational domain with the aspect ratio 5 the total number of cells varies from 112800 to 200000. The grid generated is shown below.

International Journal of Innovative Research in Science, Engineering and Technology

(A High Impact Factor, Monthly Peer Reviewed Journal)

Vol. 5, Issue 1, Januray 2016

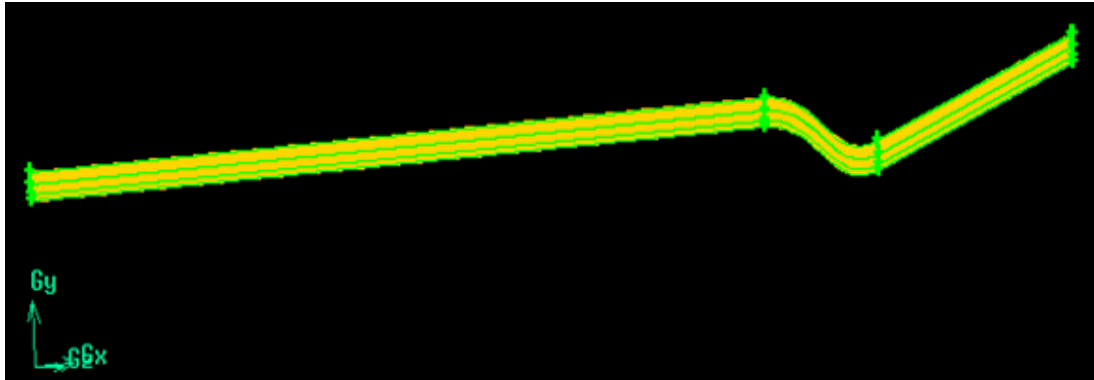

Fig.3. Grid display of the computational domain, aspect ratio 5

The total mass flow rate of the kerosene (coolant) through all the channels is 7.57 kg/s and the temperature at the inlet is 300K. Pressure outlet of 1bar is used for the outlet zone of coolant. The outermost wall of stainless steel covering is assumed to be adiabatic. The lower base copper wall is split into three sections and heat transfer coefficients at each of the section of the base wall is calculated by using Bartz Equation and CEA coding and the heat transfer coefficient thus obtained is applied on the base copper wall as boundary condition. In the case of regenerative cooling with sub cooling the inlet temperature of coolant reduces to 293K.

VII. RESULTS AND DISCUSSIONS

1. NUMERICAL ANALYSIS

(i) Aspect Ratio 5. (Regenerative cooling only)

Equations used

$$h_g = \frac{0.026 \left[\frac{\mu_g^{0.2} C_{pg}}{P_{rg}^{0.6}} \right] \left[\frac{P_c}{C^*} \right]^{0.8} \left[\frac{A_t}{A} \right]^{0.9} \sigma}{d_t^{0.2}} \quad (1)$$

Where,

$$\sigma = \left[0.5 \frac{T_{wg}}{T_c} \left(1 + \frac{\gamma-1}{2} M^2 \right) + 0.5 \right]^{-0.68} \left[1 + \frac{\gamma-1}{2} M^2 \right]^{-0.12} \quad (2)$$

$$Q_{convective} = h_g (T_{aw} - T_{ag}) \quad (3)$$

$$T_{aw} = T_c \left[\frac{1+r \left(\frac{\gamma-1}{2} \right) M^2}{1 + \left(\frac{\gamma-1}{2} \right) M^2} \right] \quad (4)$$

Where,

$$r = (P_r)^{0.33} \text{ For turbulent flows.}$$

h_g = heat transfer coefficient

d_t = Throat diameter m

μ_g = Viscosity

C_p = specific heat at constant pressure

International Journal of Innovative Research in Science, Engineering and Technology

(A High Impact Factor, Monthly Peer Reviewed Journal)

Vol. 5, Issue 1, Januray 2016

P_r =Prandtl number
 P_c =Chamber pressure
 T_{aw} =Adiabatic wall temperature K
 T_c =Combustion temperature K

I. CHAMBER SECTION

Substituting the values of μ_g , P_{rg} , C_{pg} , C^* in Bartz equation

$$h_g = 14563.92 \text{ W/m}^2\text{K}$$

Adiabatic wall temperature, by using equation (4)

$$T_{aw} = 3656 \text{ K}$$

Heat Flux

From equation (3)

$$Q_{convective} = 43.06468 \times 10^6 \text{ W/m}^2$$

ii) THROAT SECTION

Substituting the values of μ_g , P_{rg} , C_{pg} , C^* in Bartz equation

$$h_g = 23656.746 \text{ W/m}^2\text{K}$$

Adiabatic wall temperature, by using equation (4)

$$T_{aw} = 3491.85 \text{ K}$$

Heat Flux

From equation (3)

$$Q_{convective} = 64.05 \times 10^6 \text{ W/m}^2$$

iii) EXIT SECTION

Substituting the values of μ_g , P_{rg} , C_{pg} , C^* in Bartz equation

$$h_g = 4821.287 \text{ W/m}^2\text{K}$$

Adiabatic wall temperature T_{aw} , by using equation (4)

$$T_{aw} = 5786.89 \text{ K}$$

Heat Flux

From equation (3)

$$Q_{convective} = 25.4896 \times 10^6 \text{ W/m}^2$$

(ii) Aspect Ratio 5. (Sub cooling considered)

By using equations (1), (2), (3), (4)

Heat transfer coefficient at the chamber section

$$H_{\text{chamber}} = 6378.359124 \text{ W/m}^2\text{K}$$

Heat Flux

$$q_{convective} = h_g(T_{aw} - T_{ag})$$

International Journal of Innovative Research in Science, Engineering and Technology

(A High Impact Factor, Monthly Peer Reviewed Journal)

Vol. 5, Issue 1, Januray 2016

$$=6378.35912(3656-570.64)$$

$$=19.679 \times 10^6 \text{ W/m}^2$$

Heat transfer coefficient at the throat section

$$H_{\text{throat}} = 10360.6187 \text{ W/m}^2\text{K}$$

Heat Flux

$$Q_{\text{convective}} = h_g(T_{\text{aw}} - T_{\text{ag}})$$

$$= 10360.6187(3491.85 - 682) = 29.1118 \times 10^6 \text{ W/m}^2$$

Heat transfer coefficient at the exit section

$$H_{\text{exit}} = 2111.5 \text{ W/m}^2\text{K}$$

Heat Flux

$$Q_{\text{convective}} = h_g(T_{\text{aw}} - T_{\text{ag}})$$

$$= 2111.5(5786.89 - 350) = 11.4804 \times 10^6 \text{ W/m}^2$$

2. CFD Analysis

The temperature distributions of coolant along the coolant channel, temperature distributions of copper and stainless steel walls are the main focus of the study. For the rectangular channel with aspect ratio 5 the, the coolant(kerosene which is the fuel) enters at the aft end of the thrust chamber and passes through the rectangular cooling channels before it is fed to the injectors,(Single regenerative circuit). The following are the results obtained in the analysis.

(i) Aspect Ratio 5. (Regenerative cooling only)

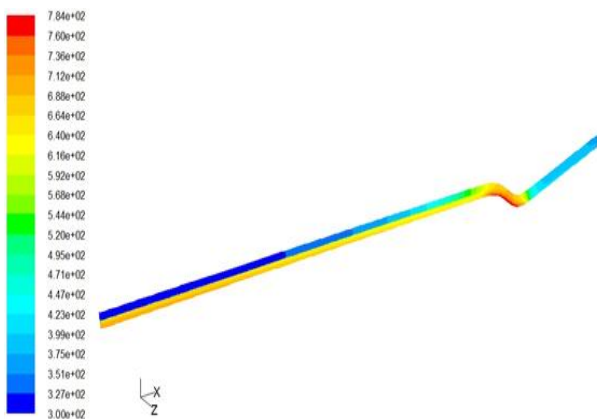

Fig. 4 (a)

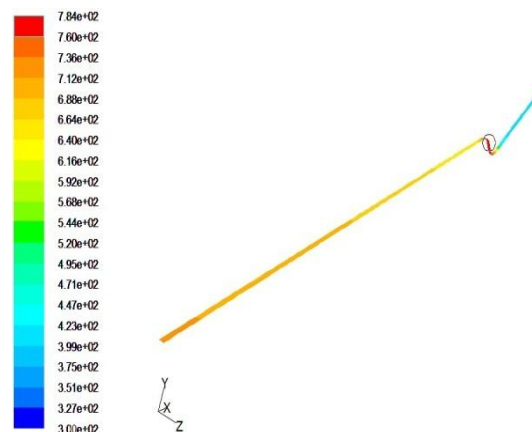

Fig. 4 (b)

Fig.4 (a) Three-dimensional schematic of computational domain and converged contour for total temperature. Fig.4 (b) Temperature contour of Cu base wall.

Figure 4 (a) shows the three-dimensional schematic of computational domain In this the total temperature varies from 300, at the end of the divergent section to a maximum of 784K at the upstream of the throat, which is well below the melting point of copper and stainless steel. Figure 4 (b) shows the base copper wall temperature variation along the length of the thrust chamber. The maximum temperature 784K is observed at the throat section which is well below the melting point of the Copper. In the case of hydrocarbon based fuels like kerosene as in the present case, there is always the chance of solid deposits inside the walls, if the wall temperature exceeds the coking limit. So it is important to

International Journal of Innovative Research in Science, Engineering and Technology

(A High Impact Factor, Monthly Peer Reviewed Journal)

Vol. 5, Issue 1, Januray 2016

investigate the coolant temperature, coolant enthalpy, coolant velocity and hot gas and coolant side wall temperatures to obtain the effectiveness of the cooling circuit.

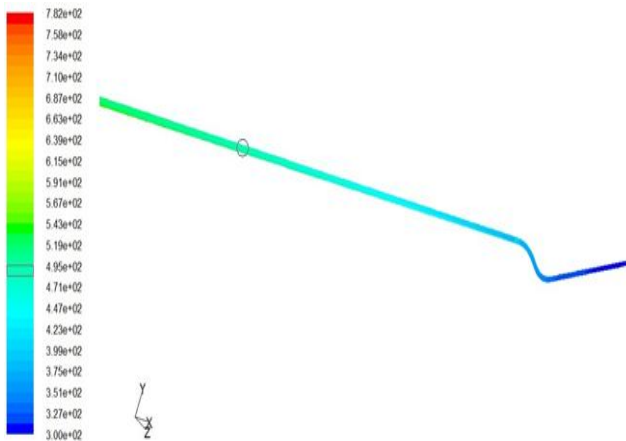

Fig. 5 (a)

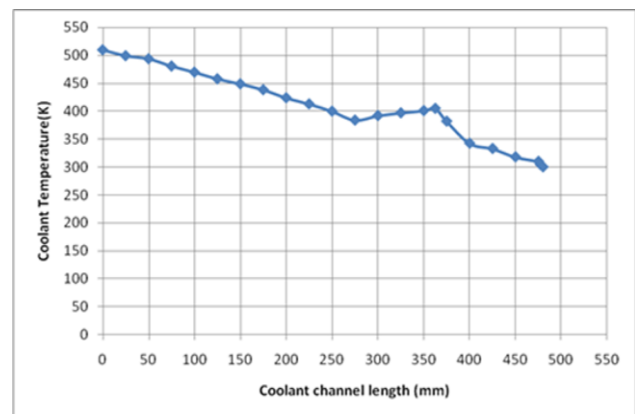

Fig. 5 (b)

Fig.5 (a) Contour of coolant temperature.Fig.5 (b) Coolant temperature distributions

Figure 5 (a) is the contour of coolant temperature and figure 5 (b) shows the coolant domain inside the rectangular channel. From Figure 5 (b) it is clear that coolant enters into the channel at temperature of 300K and is heated up to a maximum temperature of 510K which is well below the coking temperature of kerosene. Generally coking temperature for RP-1 ranges from 561-727K. The slope of the line is an indication of the amount of heat absorbed by the coolant along the axial length of the section. The slope is almost constant, except for small portion of the throat, where the heat flux is the maximum. The reason for the smooth increase of the coolant temperature along the cooling channel is the overall heat flow (product of heat flux and area) remains constant.

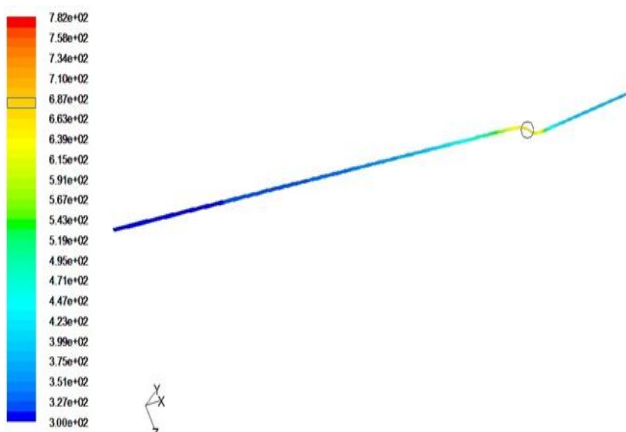

Fig. 6 (a)

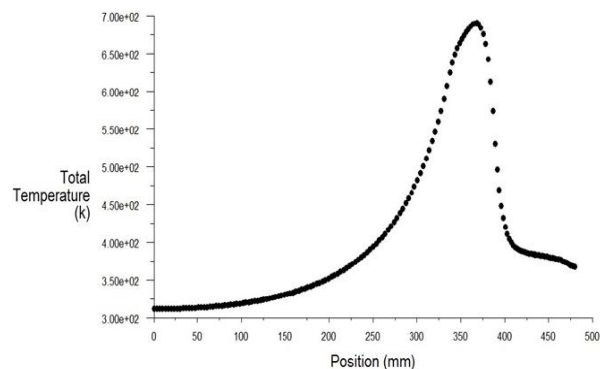

Fig. 6 (b)

Fig. 6 (a) Temperature contour of Stainless steel top wall. Fig. 6(b) Temperature distribution of Stainless steel top wall

Figure 6 (a) showstemperature contour of Stainless steel top wall and figure 6 (b) shows the temperature distribution for stainless steel top wall along the thrust chamber length and the maximum temperature is 687K which is well below the melting point of steel.

International Journal of Innovative Research in Science, Engineering and Technology

(A High Impact Factor, Monthly Peer Reviewed Journal)

Vol. 5, Issue 1, Januray 2016

(ii) Aspect Ratio 5. (Sub cooling considered)

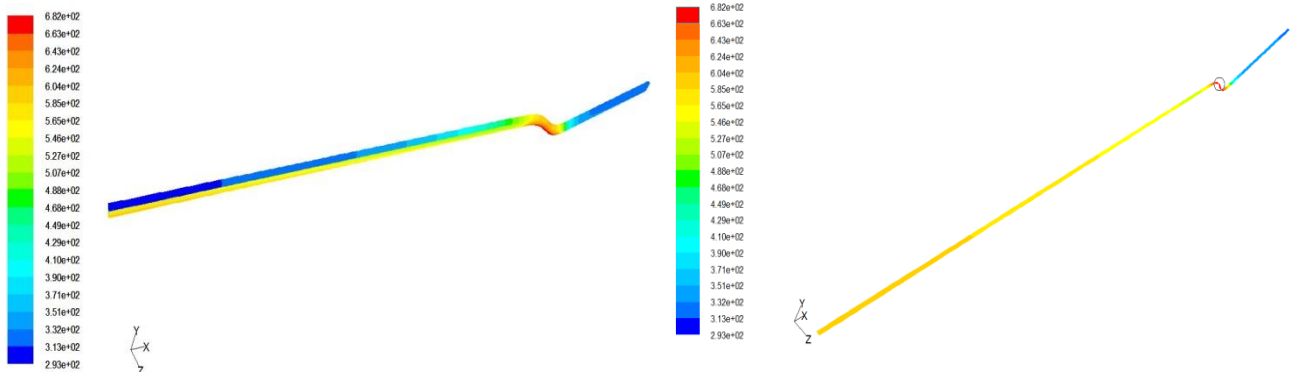

Fig. 7 (a)

Fig. 7 (b)

Fig. 7 (a) Three-dimensional schematic of computational domain and converged contour for total temperature for aspect ratio 5 with sub cooling.

Fig. 7 (b) Temperature contour of Cu base walls.

Figure 7 (a) shows that by considering sub cooling of the coolant to 293K the maximum temperature reached is 682K, ie studies shows that by comparing the regenerative cooling temperature reduced by 102K and ,so by sub-cooling to both coolant outlet and coolant inner wall temperature can be reduced. Figure 7 (b) shows the base copper wall temperature distribution. The maximum temperature 682K observed is at the throat portion and the graph shows the temperature distribution of Cu wall along the axial position of the thrust chamber

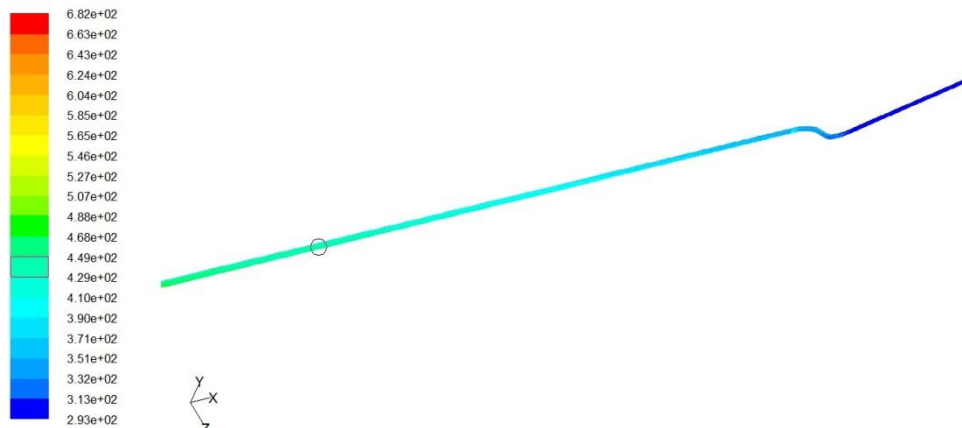

Fig.8. Contour of coolant temperature.

Figure 8 shows the coolant temperature distribution along the length of the rectangular channel. Maximum temperature observed is 449K.

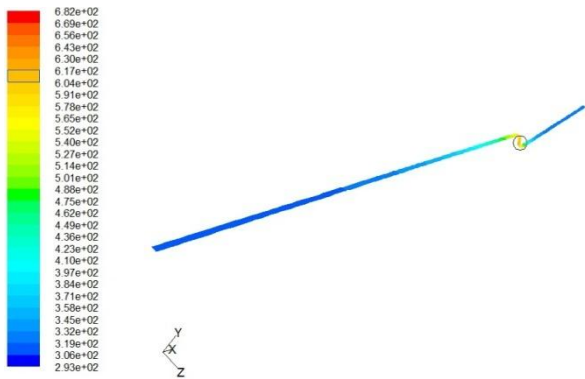

Fig. 9 (a)

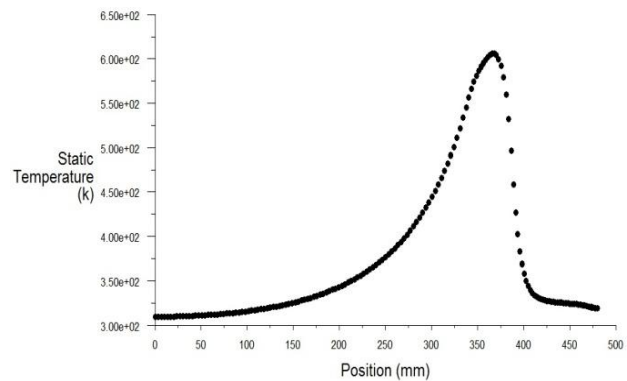

Fig. 9 (b)

Fig. 9 (a) Contour of Stainless steel top wall.

Fig. 9 (b) Temperature distribution of Stainless steel top wall

Figure 9 (a) shows the temperature contour of stainless steel top wall and figure 9 (b) shows the temperature distribution of stainless steel when considering sub cooling and the maximum temperature obtained is 617K

VIII. CONCLUSION

The effectiveness of regenerative cooling of thrust chamber is carried out by considering aspect ratio 5. Regenerative and sub cooling studies show that the wall temperatures are decreasing down into acceptable material limit at the hot gas side. Coolant temperature and coolant velocity are also shown to be in the acceptable region. The analysis shows that coolant side wall temperature tends to exceed the coking limit at the throat region. This may lead to the deposition of solid deposits within the coolant channels since kerosene, which is a hydrocarbon based fuel is used as the coolant. But by adopting sub cooling and increasing the aspect ratio of the coolant channels, reduced the coolant side wall temperature below the coking limit and hence it avoids the likelihood of coking in the coolant channel.

REFERENCES

- [1] Mary F. Wadel, "Heat Transfer in Rocket Combustion chambers", N 94-20041, SECA.Vol.2,pp 99-108.
- [2] C. L. Merkle, D. Li and V. Sankaran, "Analysis of Regen Cooling in combustion Chambers.", NASA Space Act Agreement, NCC8-200.
- [3] Daniel K.Parris and D. Brian Landrum, "Regenerative Cooling for Liquid rocket Engines", Journal of Thermal Science Vol.4, No.1, pp. 54-59.
- [4] MichealL.Meyer, "Advanced Rocket Engines" ,AIAA-2004,NATO OTAN- 74239.

ACKNOWLEDGMENT

The authors thank the Managing Director Sree Narayana Institute of Technology Adoor, Kerala for giving the financial assistance and Head of the Department, Mechanical Engineering Sree Narayana Institute of Technology Adoor, for giving valuable guidance and suggestions.

BIOGRAPHY



SARATH RAJ - Completed B Tech in Mechanical Engineering from Travancore Engineering College, Kerala and M Tech in Industrial Refrigeration and Cryogenic Engineering from ThangalKunjuMusaliar College of Engineering, Kerala. Research interests include 1. Refrigeration and Cryogenics. 2) Combustion studies in rocket fuels.3) Cooling systems in rockets.4) Automobile Engineering

International Journal of Innovative Research in Science, Engineering and Technology

(A High Impact Factor, Monthly Peer Reviewed Journal)

Vol. 5, Issue 1, Januray 2016



ASWANI RAJAN – Completed B Tech in Electrical and Electronics Engineering from College of Engineering,Perumon,Kerala and M tech in Power Systems from Saint Gits College of Engineering,Kottayam Kerala. Research interests include 1.Generation of Electrical Energy from renewable energy sources. 2) Space researches