

Methods of Performance of Solar Air Heater Using Different Artificial Roughness

Nikhil N.Kharbade¹, R.S.Shelke²

Student(M.Tech), Department of Mechanical Engineering, G.H.Raisoni College of Engineering, Nagpur, Maharashtra,
India ¹

Professor, Department of Mechanical Engineering, G.H.Raisoni College of Engineering, Nagpur, Maharashtra, India ²

ABSTRACT: Solar air heating is a solar thermal technology in which the energy from the sun is captured by an absorbing medium and used to heat air. Concept of artificial roughness on the plane paper (absorber plate) is an important technique, used to improve thermal performance of solar air heater at the cost of low to moderate friction penalty. Present study attempts the review on augmentation in heat transfer of solar air heater by artificial roughness on absorber plate. Experimental works carried out by various investigators have been reviewed on passive technique using artificial roughness to enhance the heat transfer rate. It mainly includes development analysis, performance evaluation and CFD work for solar air heater.

KEYWORDS: Solar air heater, artificial roughness, heat transfer coefficient, passive technique

I. NOMENCLATURE

Ac	Surface area of absorber plate, m ²
B	Half-length of full V-rib element,
Cp	Specific heat of air, J/kg K ,
D _h	Equivalent or hydraulic diameter of duct,
I	Intensity of solar radiation, W/m ²
K	Thermal conductivity of air, W/m K
L	Length of test section of duct or long way length of mesh,
m	Mass flow rate, kg/s P pitch,
ΔP	Pressure drop, Pa
To	Fluid outlet temperature, K
Ti	Fluid inlet temperature, K
Ta	Ambient temperature, K
T _{pm}	Mean plate temperature, K
W	Width of duct, m
e	Rib height,
g	Groove position,
h	Heat transfer coefficient, W/m ² K
H	Depth of air duct,

Dimensionless parameters-

e/h	Rib to channel height ratio
f	Friction factor
g/p	Relative groove position
Fr	Heat removal factor
Nu	Nusselt number
N _{us}	Nusselt number for smooth channel

International Journal of Innovative Research in Science, Engineering and Technology

(An ISO 3297: 2007 Certified Organization)

Vol. 5, Issue 1, Januray 2016

N_{ur}	Nusselt number for rough channel
p/e	Relative roughness pitch
Pr	Prandtl number
Re	Reynolds number
St	Stanton number
W/H	Duct aspect ratio
$e/D, e/Dh$	Relative roughness height
$\Delta T/G$	Maximum exergetic efficiency
Greek symbols-	
ϕ	Rib chamfer angle, degree
η_{th}	Thermal efficiency
μ	Dynamic viscosity, Ns/m^2
ρ	Density of air, kg/m^3
α	Angle of attack, degree

II. INTRODUCTION

Energy is an primary agent for economic development. Energy resources are classified into conventional and non-conventional energy resources. Solar energy widely available on the earth is used to convert into thermal energy. World demand for energy is expected to more than double by 2050 and to more than triple by the end of the century. The way to increment in network of producing energy is not sufficient to develop sustainable energy. Finding sufficient supplies of clean energy for the future is challenging. [1]

There are many ways to utilize energy but solar air heater have an important role in the energy storage and utilization. Solar air heater is a device which absorbs all solar radiation incidents on it shown in *fig. 1* (conventional solar air heater). [2,3]

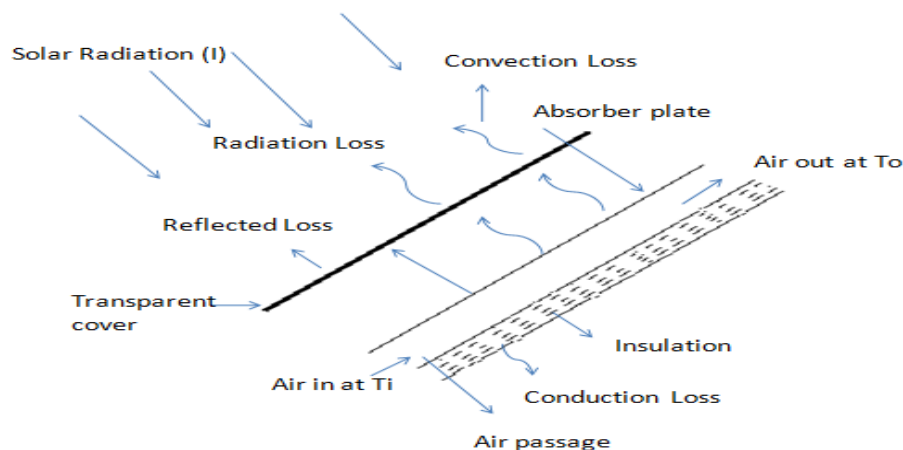

Fig 1. Conventional solar air heater

There are many method to enhance the heat transfer rate by twisted tapes, wire coils, ribs, fins, dimples, etc., are the most commonly used passive heat transfer augmentation tools. Artificial roughness is a passive heat transfer enhancement technique by which thermo- hydraulic performance of a solar heater can be improved. Until now many researchers are working on the heat transfer augmentations techniques to enhance the rate of heat transfer without affecting much the overall performance of the system. [4]

International Journal of Innovative Research in Science, Engineering and Technology

(An ISO 3297: 2007 Certified Organization)

Vol. 5, Issue 1, Januray 2016

Different methods of heat transfer enhancement are as follows:

- a) Passive Technique
- b) Active Technique
- c) Compound technique

This review is based on passive techniques using artificial roughness.

2.1 Concept of artificial roughness

Thermal performance of solar air heater can be improved by providing artificial roughness on the absorber plate. Smooth surface has viscous and laminar sub-layer because of that low heat transfer coefficient. To enhance the heat transfer coefficient turbulence has to be created near the surface of plate. So, artificial roughness technique is used for creating turbulences in a duct as shown in **fig 2**. To represent roughness following parameter are mostly used

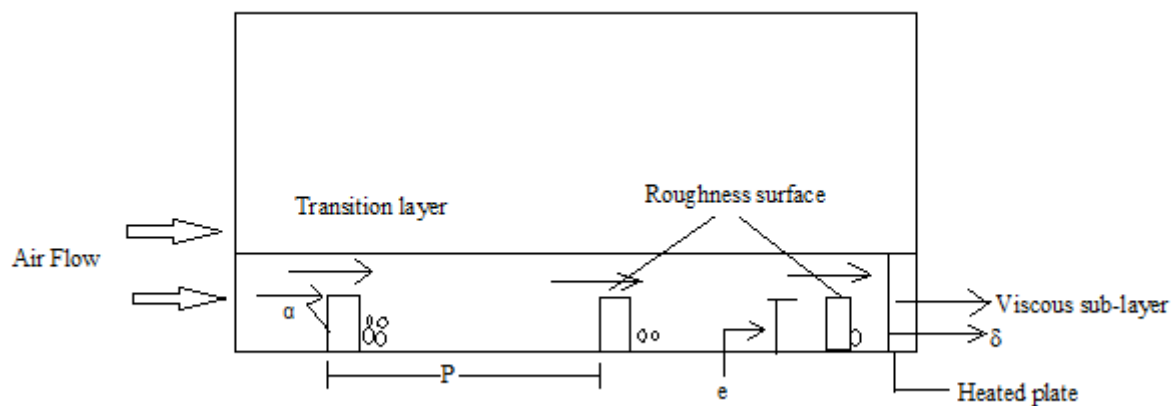

Fig 2. Roughness geometry with air flow in a duct

- a) Relative pitch(p/e) : It is ratio of distance between two consecutive rib and height of rib
- b) Relative roughness height (e/δ): It is the ratio of rib height to equivalent diameter of the air passage
- c) Angle of attack (α) : Inclination of rib to with direction of flow in duct
- d) Shape of roughness element: depend upon shape where as it is 2-D,3-D, discrete shape or various shape etc
- e) Aspect ratio: It is a ratio of width to height of duct (w/h).

2.2 Aim and objectives

Aim of this reviews to present the status of various authors reviews on passive technique in solar air heater.

Objectives are as follows.

- A. To collect all passive techniques used to improved thermal performance of solar air heater.
- B. To collect all passive techniques used to improved thermal performance of solar air heater
- C. To review artificial roughness in the form of different type of shape are 2 to 4 time as compares to conventional type of system.

III. REVIEW ON SOLAR AIR HEATER WITH ARTIFICIAL SURFACE ROUGHNESS

Experimental work based on passive technique used for artificial surface roughness is review and is divided into following points:-

- 1] Analysis on solar air heater
- 2] Performance evaluation on solar air heater

International Journal of Innovative Research in Science, Engineering and Technology

(An ISO 3297: 2007 Certified Organization)

Vol. 5, Issue 1, Januray 2016

- 3] Experimental study on solar air heater
- 4] CFD based analysis on solar air heater
- 5] Author reviews on solar air heater

3.1 Analysis on solar air heater-

Anil Kumar [5], has analysis of heat transfer and fluid flow in different shaped roughness element on the absorber plate by using CFD analysis. He had done his CFD work on three shape thin circular wire in V-shaped, multi V-shaped rib & multi V-shaped rib with gap also perform the effect of roughness parameter on thermal performance.

Maximum heat transfer enhancement is observes in multi V-shaped rib with gap (Renormalization k-epsilon model) than other two. Also result where obtain, heat transfer enhancement is to be increased to 1.7, 4.7, 5.6 times compared to smooth aluminium absorber plate Roughness geometry shown in **fig 3**.

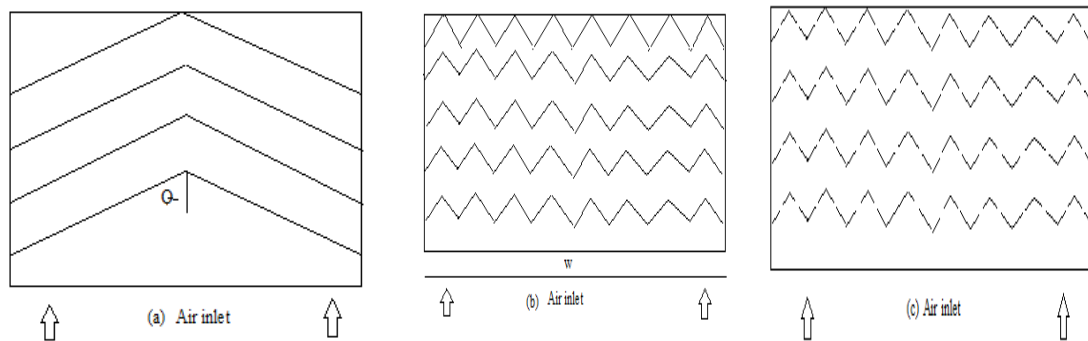

Fig 3 (a) V-shaped rib, b) Multi v-shaped rib, (c) Multi v-shaped with gap rib Ref [5]

Wei Chang et al. [6], Analysis the theoretical and experimental research on thermal performance of solar air collector with finned absorber. The effect of setting angle, medium flow and air inlet mode on solar air collector is analyzed and theory calculation model of it is confirmed by experiment. He was also done his job on back side of fins Shown in **fig 4**. Finally result show that the error between the theory calculation model and experiment around 9%.

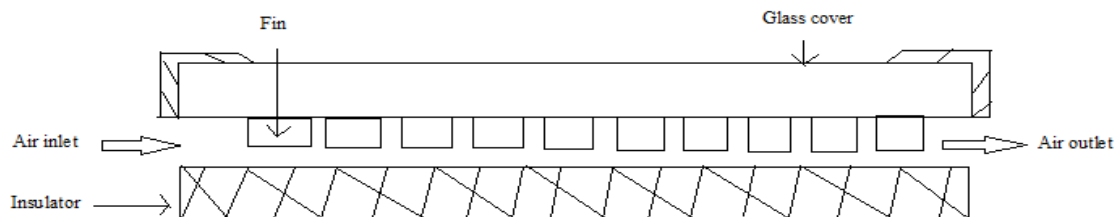

Fig 4. The internal structure diagram of collector

Mohammed O.A. Hamid et al. [7], had been done his analysis on field synergy for turbulent heat transfer on ribs roughened solar air heater .In this experiment he used field synergy equation to increase the field synergy between the velocity vector and temperature gradient fields to enhance the convective turbulent heat transfer. By using field synergy equation, optimal flow field of swirls flow under ribs and the cavity area is obtained and ultimately Nusselt number is gradually increases. Swirls flow is obtain by design of solid inclined, curved and vertical baffles so overall coverage of turbulence heat exchanger is enhanced. Finally maximum result was obtained for solid curved baffles mounted near the absorber plate.

Sami Kooli et al. [8], has been doing there analysis on the effect of nocturnal shutter on insulated greenhouse using a solar air heater with latent storage energy. He is taken two similar greenhouse with a nocturnal shutter are constructed. This whole set up installed in research and technology centre of energy. At day time, latent energy is stored in solar air heater and can be restored at night time. Hence energy consumption is reduce. Analysis is performing with or without

International Journal of Innovative Research in Science, Engineering and Technology

(An ISO 3297: 2007 Certified Organization)

Vol. 5, Issue 1, Januray 2016

nocturnal shutter. Finally result were obtained nocturnal variation of temperature inside the greenhouse exceed 2°c between with shutter and without shutter.

B. N. Prasad et al. [9], recently present and analysis of plate temperature and heat transfer characteristics of artificially roughened solar air heater by using three solar air heater .The overall paper present experimental result of enhancing the intensity of radiation by means of booster mirrors and heat transfer by proving artificial roughness on absorber plate shown in **fig 5**. 40% increment has been found by using booster mirror over the normal incident radiation. For the experimentation three solar air heater has been taken .the wide range of roughness and flow parameter to be taken as $p/e = 8$ to 40 , $\epsilon/d = 0.0112$ to 0.0288 , mass flow rate ranging from 0.01576 to 0.0386 , Re in between 8478 to 10696 . 20 set of roughness absorber plates have been tested. Finally result shows that heat removal factor Fr and plate efficiency factor both enhance in the range of 90% to 135% as compare to smooth plate and 10% to 15% as compare to roughened .

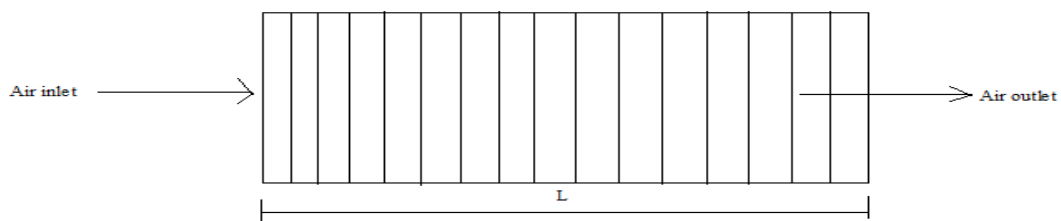

Fig 5. Absorber plate with artificial roughness

Sukhmeet singh et al. [10], the experiment present the thermo- hydraulic performance comparison in between V-down ribs with gap and similar reported rib roughness geometry. In this experiment flow- attack angle is 60° and relative roughness height 0.043 , duct aspect ratio 12 and reynolds number ranging from 3000 to 15000 shown in **fig 6**. Roughness wall is insulated from three side. Roughness pitch of 4,6,8,10,12 have been tested. From this experiment maximum thermal performance is found at pitch roughness 8. And maximum nusselt number and friction factor is found to be 2.70 and 2.86. For better thermal performance better reynold number is reviewed as 3000-12000.

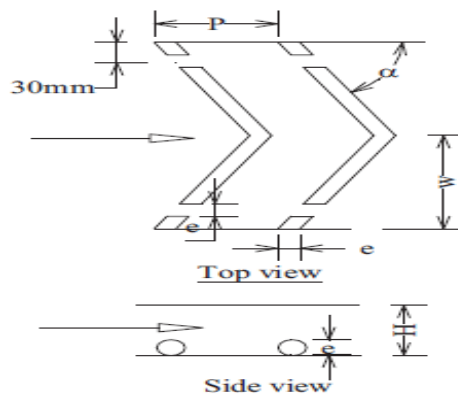

Fig 6.V-shaped roughness geometry on absorber plate. Ref [10]

3.2 Performance evaluation on solar air heater

Ting-ting Zhu et al. [11], investigate on the performance of a novel solar air heater based on flat micro-heat pipe array [FMHPA]. He connects all 19 heat-collecting units i.e. with solar air heater shown in **fig 7**. Solar air heater tilted to form angle of 45 degree. Result shows that, average thermal efficiency of the solar air heater is up to 70% of stable operation.

International Journal of Innovative Research in Science, Engineering and Technology

(An ISO 3297: 2007 Certified Organization)

Vol. 5, Issue 1, Januray 2016

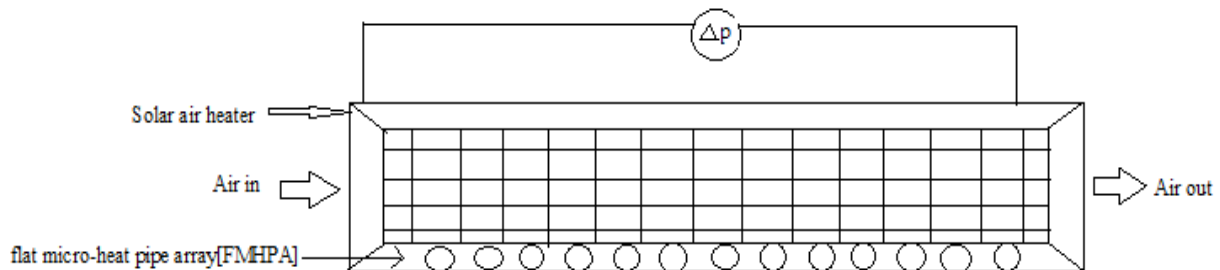

Fig 7. Schematic diagram of experimental system

D.S. Rawat [12], evaluate the performance of two pass solar air heater using 60 degree inclined shaped ribs on absorber plate, for rib he has taken $e/D = 0.0287$, while the rib pitch to height ratio was $p/e = 6-12$. Experiment was carried out by taking air as convective fluid. Also study has been done in Reynolds number between 3000-15000. The structure of solar heater duct is two pass of air first one is upper passing of air and second one is reverse direction passing of air through duct. In his experiment he use v-shaped rib on the aluminium absorber plate, rectangular duct consist of entry section, testing section, exit section, Orifice meter, blower, micro-manometer, manometer. Testing is carried out by changing roughness pitch ratio 6-10 shown in **fig 8**. Finally result is obtain at $P/e = 10$. i.e. better thermal performance is obtain at 10. Enhancement in heat transfer coefficient and thermal performance is 3.96 and 1.82 times as compare to smooth plate.

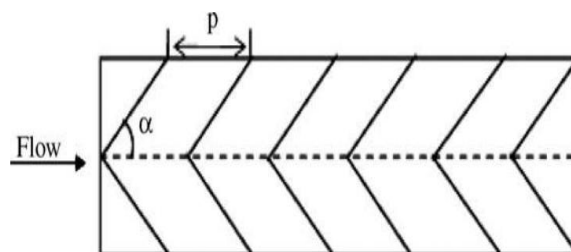

Fig 8. Surface roughness on aluminium absorber plate Ref [12]

Anil Kumar Patil et al. [13], Examine the augmentation in heat transfer and friction in a flow through solar air heater duct with discretized broken V-rib roughness. He had done his study between Reynolds number from 3000 to 17,000. In discretized broken V-rib have relative gap position (s'/s) from 0.2 to 0.8, relative staggered rib position (p'/p) from 0.2 to 0.8 have been presented and discussed. Following **fig 9**. Shows the roughness geometry on the absorber plate Finally result are obtain as

- a) Better order turbulence as compared to the smooth & continuous rib
- b) The maximum enhancement in Stanton number is obtained as 3.12 correspond to rib position, $P'/P = 0.6$
- c) It shows that effective efficiency is strong function of roughness and operating parameter.
- d) Optimum set of roughness parameter is strong function of temperature rise parameter and intensity of solar radiation.

International Journal of Innovative Research in Science, Engineering and Technology

(An ISO 3297: 2007 Certified Organization)

Vol. 5, Issue 1, Januray 2016

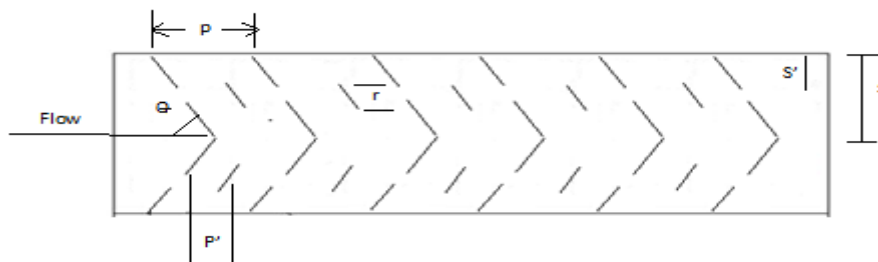

Fig 9. Discretized broken V-rib roughness

S. A. Nagalkar [14], experimentally investigate better thermal performance for solar air heater by introducing multi arc shape artificial roughness on the absorber plate. Multi arc shape geometry is shown in **fig 10**. He tested continuous multi arc shape rib on the absorber plate into the rectangular duct with air as a fluid medium by three times with various relative roughness pitch size 15, 20, 25. Experimental set up is very simple it contains rectangular Box with three section inlet section, testing section, outlet section. Further box connected with pipe with the help of plenum, after that it contain orifice meter and manometer, and last blower with flow control valve. Pressure drop is measure across test section with the help of micro-manometer. Maximum heat transfer coefficient obtain at pitch ratio $P/e = 15$. He observed that 51% increase in heat transfer with respect to smooth plate and increase in friction factor 40%

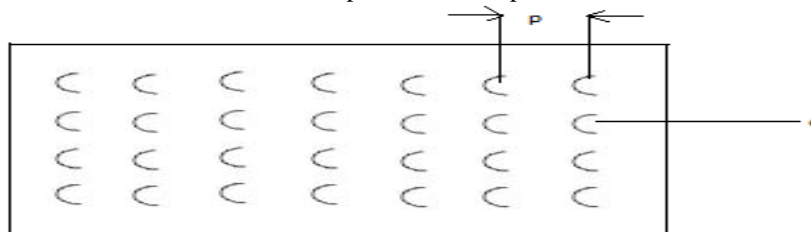

Fig 10. Continuous multi-arc shape rib

Tabish Alam et al. [15], investigate the effect of circularity of perforation holes in V-shaped blockages on heat and friction factor characteristics of rectangular solar air heater duct. He created a hole on the V-shaped rib from circular to square shown in **fig 11**. With varying relative pitch of 4 to 12, relative blockage height of 0.4 to 1.0, open area ratio of 5% -20% ,angle of attack 30-75 degree, also experiment has been done in Reynolds number between 2000 and 20,000. This absorber plate is expose to uniform heat flux . Finally result where obtained

- a) Non-circular perforation holes were found out in higher heat transfer as compare to circular hole.
- b) Maximum heat transfer rate and friction factor is found at 60 degree
- c) Highest value of Nusselt number is found at pitch ratio $P/e = 8$, and $f = 4$.

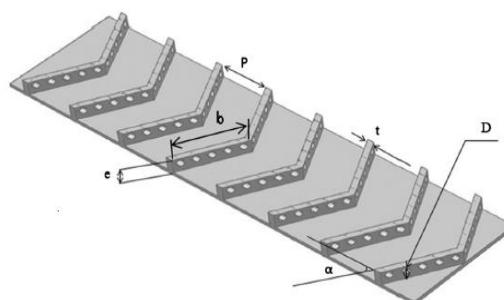

Fig 11. V-shaped rib with hole on absorber plate Ref [15]
 b = length of limb, e = height of block, t = thickness of block, p = pitch
 α = Angle of attack, D = diameter of perforation

International Journal of Innovative Research in Science, Engineering and Technology

(An ISO 3297: 2007 Certified Organization)

Vol. 5, Issue 1, Januray 2016

Sanjay Yadav et al. [16], perform the exegetic evaluation of solar air heater having arc shape oriented protrusions as roughness element shown in *fig 12*. In this experiment exegetic efficiency of roughened solar air heater duct provided with protrusions arranged in arc fashion over the absorber plate. Finally result were calculated and compared with smooth flat-plate solar air heater.

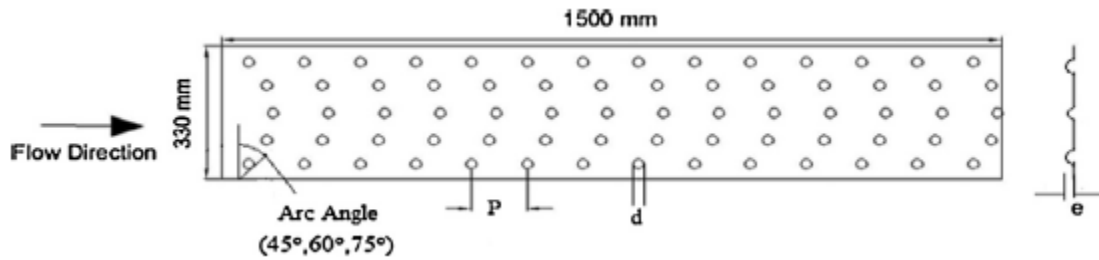

Fig 12. Protruded roughened geometry in arc shape ref [16]

3.3 Experimental study of solar air heater

Jie Deng and Xudond Yang [17], experimentation has to be done on single pass flat- plate solar air collector by dust deposition on surface. The experimentation is carried out by comparing two smooth surfaces one is smooth and other is dust deposition. Result shows that thermal efficiency in case of sever dust deposition is decreases by 10.7 -21.0%. When temperature difference is ranges from 0 to 0.04.

Foued Chabane et al. [18], analysis on experimental study of heat transfer and thermal performance with longitudinal fins of solar air heater. He used longitudinal fins on back side of absorber plate shown in *fig 13*. Also he used mass flow rate from 0.012 to 0.016 and solar air heater inclined with angle of 45 degree. By doing so, maximum efficiency is obtained by using fins near about 5.1% to 5.83% by rate than without fins respectively. The maximum thermal efficiency values obtained 40.02%, 51.50% with fins with mass flow rate 0.012 kg/s and 34.92%, 43.94% without fins with mass flow rate 0.016 kg/s.

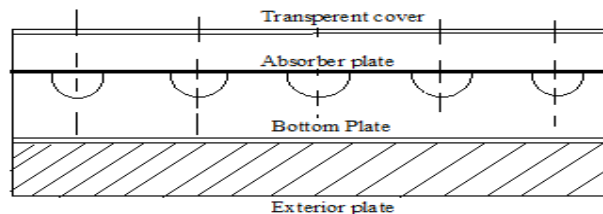

Fig 13. Schematic view of the aluminium absorber plate with fins

S.S. Pawar et al. [19], investigate the Nusselt number and friction factor in solar air heater duct with diamond shaped rib roughness on absorber plate shown in *fig 14*. For diamond shape he varied relative pitch from 10 to 25 mm also varied relative roughness height 0.023 & 0.028 mm .Height is varied as 1 & 1.25 mm. He had done his work in Reynolds number ranging from 3000 to 14000. At relative roughness pitch ratio 15 find best roughness pitch ratio, maximum values of Nu find to be 84.72 at Re number 14012 and Fr is 0.0194 at Re 3010.

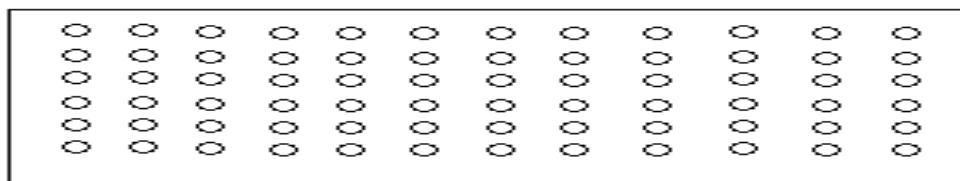

Fig 14. Diamond shape on absorber plate

International Journal of Innovative Research in Science, Engineering and Technology

(An ISO 3297: 2007 Certified Organization)

Vol. 5, Issue 1, Januray 2016

Adisu Bekele et al. [20], experiment is perform on solar air heater with surface mounted obstacles with delta-shaped obstacles on the absorber plates shown in *fig 15*. He used to calculate performance characteristics of solar air heater. In this experiment he used following parameter.

- Reynol number – 2100 to 30,000
- Relative obstacle height (e/H) – 0.25 to 0.75
- Relative obstacle longitudinal pitch (Pl/e) – $3/2$ to $11/2$
- Relative obstacle transverse pitch (Pt/b) – 1 to $7/3$
- Angle of incidence - 30° to 90° .

By taking this parameter he compare his study with previous work. The maximum thermo-hydraulic performance is obtain at $(Pl/e) = 3/2$ for all obstacle height Delta shaped obstacle is found to be superior than any other SAH at angle of 30° and 60° .



Fig 15. Delta shaped obstacles on sbsorber plate

3.4 CFD based analysis on solar air heater

Anil singh Yadav [21], had been done his CFD work on artificial roughness solar air heater having equilateral triangular sectioned rib on absorber plate. Numerical investigation is done to analyse two dimensional Navier-strok flows through rectangular duct from reynolds number 3800 to 18,000. In this experiment he taken roughness pitch ratio $p/e = 7.14 - 35.71$ and $e/d = 0.021 - 0.042$. For doing CFD work, Ansys fluent is used for turbulent flow inside the rectangular duct .In this experiment average heat transfer and fluid friction in an artificial roughned solar air heater are presented and discuss .also effect of grid distribution on numerical prediction also discuss .

A. Boulemtafes-Boukadoum [22], Perform CFD based analysis on solar air heater provided with transverse rectangular ribs. He had been done his job on Numerical simulation to analyse the flow and heat transfer in the duct of a solar air heater provided with transverse rectangular ribs. Force convection has to be done with absorber plate heated with uniform flux. Researcher used RANS formulation to model the flow ,since the flow is turbulent. In this he solve continuity, momentum and energy eqation in turbulent mode. finally, effect of Parameter like Reynold number, Nusselt number, f , thermo-hydraulic performane parameter has been investigated.

Raheleh Nowzari et al. [23], had been done his work on single and double pass solar air heater with perforated cover and packed mesh. He used single and double pass solar air collector with normal glazing and quarter perforated cover was expermentally investigated. Solar air heater is tested with two different perforated cover in which whole is made with diameter 20 and on the other cover is 10 D. With vary mass flow rate the efficiency of double pass is always greater than single pass air heater by 5-22.7%.

3.5 Review paper on solar air heater

D.S. Rawat [24], working on enhancement of heat transfer using artificial roughness in solar air heater. He reviewed that introduction of artificial roughness in the field of heat transfer in various shape and modification made by researcher. His paper also covered that various literature review that uses various roughness geometry, there technique , correlations to evaluate the heat transfer rate and analysis the result. His paper conclude that artifial roughness in the form of different shapes of ribs increases heat transfer rate around 2 to 4 times as compares to conventional type of system.

Sanjay K. Sharma [25], has done his work on thermo-hydraulic performance analysis of solar air heater having artificial roughness . He was reviwed various literature to summarize and conclude the investigation involving the use

International Journal of Innovative Research in Science, Engineering and Technology

(An ISO 3297: 2007 Certified Organization)

Vol. 5, Issue 1, Januray 2016

of small height element and surface protrusion on absorber plate and also shape geometry and its effect on heat transfer and friction factor through experiment .

In this paper he has been doing his comparative study to understand the result of this investigation for solar air heater with different roughness element.

Table 1 shows comparison of thermo-hydraulic performance parameter of current rib geometry and similar reported rib geometry for solar air heater.

Sir No.	Authors	Roughness element	Reynolds number	Non dimentional parameter			Results
				P/e	e/D _h	α	
1.	Anil Kumar [5]	V-shaped rib	-	10	0.43	60	-Renormalization k-epsilon model found good result - η_{th} & f is maximum for multi V-shape rib with gap
		Multi V-shape rib		10	0.43	60	
		Multi V-shape with Gap rib		10	0.43	60	
2.	Wei chang et al. [6]	Fins	-	-	-	-	The result error between theory calculation model and experiment around 9%.
3.	Mohammed O.A. Hamid et al. [7]	Continuous rib tabulators	-	-	-	-	Solid curved baffles mounted near absorber plate is the best novel design.
4.	Sami kooli et.al. [8]	Nocturnal shutter	-	-	-	-	Exceed 2° c temp in with shutter compare to without shutter.
5.	B.N.Prasad, G.N.Sah [9]	Line wired	8478-10696	8 - 14	0.0112 - 0.0288	-	Fr and F is increases 90-135% compare to smooth solar air heater
6.	Sukhmeet singh et al. [10]	V-down rib with gap	3000-15000	4-12	-	60	Nu=2.70 Fr=2.86
7.	D.S. Rawat et al. [12]	V-shape rib	3000-15000	6-12	0.0287	60	h & η_{th} =3.96 & 1.82 times smooth plate
8.	Anil Kumar Patil et al. [13]	Discretized broken V-Rib shape	3000-17,000	-	-	-	s'/s & p'/p =0.2-0.8 , Maximum St found that 3.12

International Journal of Innovative Research in Science, Engineering and Technology

(An ISO 3297: 2007 Certified Organization)

Vol. 5, Issue 1, Januray 2016

9.	S. A. Nagalkar et al. [14]	Multi arc shape	6000-21000	15-25	0.37	90	Nu=327 F=0.068
10.	Tabish Alam et al. [15]	Perforation holes in V-shaped	2000-20,000	4-12	0.4-1.0	30-75	Nu=6.76 f=28.84
11.	Sanjay Yadav [16]	Arc shape protrusions	1000-40,000	12-24	0.015-0.03	45-75	$\Delta T/G=0.02$
12.	Ting-Ting Zhu [11]	Flat micro-heat array	-	-	-	45	Thermal efficiency $\eta_{th}=70\%$
13.	Jie Deng [17]	Dust deposition	-	-	-	-	Thermal efficiency decrease from 10.7-21%
14.	Foued Chabane et al. [18]	Longitudinal fins	-	-	-	45	For, $m=0.016$, $\eta_{th}=51.50\%$
15.	S.S. Pawar et al. [19]	Diamond shape rib	3000-14000	10-25	0.023-0.028	-	Nusselt number found to be Nu=84.72
16.	Adisu Bekele et al.[20]	Delta-shaped obstacles	2100-30,000	3/2-11/2	0.25-0.75	Angle of incident 30°-90°	At this angle of incident, Delta shaped obstacles is found superior than any other SAH previously studied.
17.	Anil singh Yadav [21]	equilateral triangular sectioned rib	3800-18,000	7.14 - 35.71	0.021 - 0.042	-	The optimum value of thermo-hydraulic performance parameter has been found to be 2.11 for Reynolds number (Re) of 15,000

International Journal of Innovative Research in Science, Engineering and Technology

(An ISO 3297: 2007 Certified Organization)

Vol. 5, Issue 1, Januray 2016

IV. CONCLUSION

In this paper, the effort has been made to review the work carried out by researchers on the artificial roughness on the absorber plate in solar air heater. It is observed that, better performance is obtained for turbulence formation on roughened surfaces. In a nut shell, it is found that-

- a) With artificial roughness, thermal performance of absorber plate increases with minimum friction factor.
- b) All passive techniques used to improve thermal performance of solar air heater have better result 2 to 4 times that of smooth surface (conventional type of system).
- c) In general, Nusselt number increases with an increase of Reynolds number. The value of Nusselt number is substantially higher as compared to those for smooth absorber plate.

REFERENCES

- [1] Dharam Singh et al., "Heat transfer enhancement of solar air heater by using artificial roughness –a review," IJETT, vol. 4, no. 10, p. Volume 4 Issue 10, Oct 2013.
- [2] Brij bhushan et al., "A review on methodology of artificial roughness used in duct of solar air heater," Energy , vol. 35, pp. 202-212, 2010.
- [3] Vipin B. Gawande et al., "Effect of roughness geometries on heat transfer enhancement in solar thermal systems – A review," Renewable and sustainable energy reviews, pp. 347–378, 2014.
- [4] A. Dewan et al., "Review of passive heat transfer augmentation techniques," Proc. Instn. Mech. Engrs. Power and Energy, vol. 218.
- [5] Anil Kumar, "Analysis of heat transfer and fluid flow in different shaped roughness elements on the absorber plate solar air heater duct," in 2013 ISES Solar World Congress, 2014, pp. 2102-2111.
- [6] Wei Chang et al., "The theoretical and experimental research on thermal performance of solar air collector with finned absorber," in International conference on solar heating and cooling for buildings and industry, SHC 2014, 2015, pp. 13 – 22.
- [7] Mohammed O.A. Hamid et al., "Field synergy analysis for turbulent heat transfer on ribs roughened solar air heater," Renewable Energy, vol. 83, pp. 1007-1019, 2015.
- [8] Sami Kooli et al., "The effect of nocturnal shutter on insulated greenhouse using a solar air heater with latent storage energy," Solar Energy , vol. 115, pp. 217–228, 2015.
- [9] B. N. Prasad et al., "Plate temperature and heat transfer characteristics of artificially roughened solar air heater," Energy Procedia 62 , pp. 256 – 269, 2014.
- [10] Sukhmeet Singh et al., "Thermo-hydraulic performance due to relative roughness pitch in V-down rib with gap in solar air heater duct—comparison with similar rib roughness geometries," Renewable and sustainable energy reviews 43, pp. 1159–1166, 2015.
- [11] Ting-ting Zhu et al., "Experimental investigation on the performance of a novel solar air heater based on flat micro-heat pipe arrays (FMHPA)," in International Conference on Solar Heating and Cooling for Buildings and Industry, SHC 2014, 2015, pp. 146 – 154.
- [12] D.S. Rawat et al., "Performance evaluations of two pass solar air heater using 60° inclined v-shaped ribs on absorber plate," International journal of engineering science invention, vol. 3 , no. 8, pp. 2319 – 6726, August 2014.
- [13] Anil Kumar Patil et al., "Experimental investigation of enhanced heat transfer and pressure drop in a solar air heater with discretized broken V-rib roughness," ASME, vol. 137, pp. 021013-1, April 2015.
- [14] S. A. Nagalkar et al., "Heat transfer enhancement in solar air heater having multi-arc shape artificial Roughness with gap," in International conference on technologies for sustainable development (ICTSD-2015), Feb. 04 – 06, 2015, Mumbai, India, 2015.
- [15] Alam Tabish et al., "Effect of circularity of perforation holes in V-shaped blockages on heat transfer and friction characteristics of rectangular solar air heater duct," Energy Conversion and Management , vol. 86, pp. 952–963, 2014.
- [16] Maneesh Kaushal, Varun, Siddhartha Sanjay Yadav, "Exergetic performance evaluation of solar air heater having arc shape oriented protrusions as roughness element," Solar Energy, vol. 105, pp. 181-189, 2014.
- [17] Jie Deng et al., "Experimental study of a single-pass flat plate solar air collector with severe dust deposition on the transparent glass cover," in International conference on solar heating and cooling for buildings and industry, SHC 2014, 2015 , pp. 32 – 40.
- [18] Foued Chabane et al., "Experimental study of heat transfer and thermal performance with longitudinal fins of solar air heater," Journal of Advanced Research , vol. 5, pp. 183–192, 2014.
- [19] S. S. Pawar et al., "Experimental study of nusselt number and friction factor in solar air heater duct with diamond shaped rib roughness on absorber plate," AJER, pp. Volume-02, Issue-06, pp-60-68, 2013.
- [20] Adisu Bekele et al., "Performance characteristics of solar air heater with surface mounted obstacles," Energy Conversion and Management , vol. 85, pp. 603–611, 2014.
- [21] Anil Singh Yadav et al., "A CFD based thermo-hydraulic performance analysis of an artificially roughened solar air heater having equilateral triangular sectioned rib roughness on the absorber plate," International Journal of Heat and Mass Transfer 70, pp. 1016–1039, 2014.
- [22] A. Boulemtafesafes-boukodoum, "CFD based analysis of heat transfer enhancement in solar air heater provided with transverse rectangular rib," in The international conference of technologies and material for renewable energy, environmental and sustainability, TMREES14, 2014 , pp. 761 – 772.
- [23] Raheleh Nowzari et al., "Single and double pass solar air heaters with partially perforated cover and packed mesh," Energy, vol. 73, pp. 694-702, 2014.
- [24] D.S. Rawat et al., "Enhancement of heat transfer using artificial roughness in solar air heater," International journal of engineering science invention, vol. 3, no. 6, pp. 50-63, 2014.
- [25] Sanjay K. Sharma et al., "Thermo-hydraulic performance analysis of solar air heaters having artificial roughness –a review," renewable and sustainable energy review , vol. 41, pp. 413-435, 2015.