

International Journal of Innovative Research in Science, Engineering and Technology

(An ISO 3297: 2007 Certified Organization)

Vol. 5, Issue 1, January 2016

Thermodynamic Analysis of Rice-Husk Fired Cogeneration Plant

M. Dubey^{1*}, H. Chandra², A. Arora³

Associate Professor, Department of Mechanical Engineering, B. I. T. Durg, (C.G.), India¹

Associate Professor, Department of Mechanical Engineering, V. E. C., L. S. U. Ambikapur (C.G.) – India²

Professor, Department of Mechanical Engineering, B. I. T. Durg, (C.G.), India³

ABSTRACT: Rice husk is residue from rice milling process. Production of rice paddy is associated with the production two byproducts, rice husk and rice bran. In the majority of rice producing countries much of the husk produced from the processing of rice is either burnt for heat or dumped as a waste. India alone produces around 120 million tons of rice paddies per year, giving around 24 million tons of rice husks per year. Rice husk can be used in an economical way to meet the energy demand within the rice milling industry by using rice husk as fuel for heat and power production to supply the heat and electricity in the processes, and to produce surplus electricity for selling to the national grid. In this paper taking two cases for study first is thermal-match and second one is rice husk-match cogeneration. These are used as energy utilization and considered for economic evaluation of power plants to meet different demand categories. The rice husk-match cogeneration is more economically feasible than the thermal-match cogeneration obtained from result. The back pressure steam-fired boiler capacity is 18 tons/hour of steam at 25 bar (absolute) and 400°C. The rice husk-match cogeneration can generate power of 1,432 kW while the thermal-match cogeneration can produce power only 923 kW. The two cases of the study are based on 180 days/year of operation of rice mill cogeneration.

KEYWORDS: Energy, Exergy, Rice husk cogeneration, Steam turbine, Electricity generation.

I. INTRODUCTION

India is an agricultural-based country. It is one of the world's leading producers of paddy rice. Rice husk contains 75-90% organic matter such as cellulose, lignin, and rest mineral components such as silica, alkalis and trace elements Kumar, et al. [1]. This agro-residue has a large dry volume, and as a consequence, most rice husk can be made into pellets or briquettes to save storage space and transport the biowaste economically due to its low bulk density (90-150 kg/m³) Hwang, et al. [2]. Rice husk is defined as renewable energy resource which can be used to mitigate greenhouse gas emissions. Conversion of rice husk into heat, steam, gas or liquid fuels would benefit countries that have no traditional energy resources and have an abundant supply of this agro-residue. Promoting the use of rice husk for the energy sector would mitigate local environmental problems, e.g., rice husk dumping and open burning, and highlight the benefits of greenhouse gas reduction to the community and environment Pham, et al. [3]. Co-generation of heat and power has been used for decades in various industries such as food processing, wood, textiles, pulp and paper, chemical, petrochemical industries and others. An increasing trend is seen in the applications of co-generation in not only these conventional fields, but also in industrial estates and in buildings to cover the heat and/or cooling requirements. Direct combustion is also the most common way of producing heat and/or power from rice husk in both large and small scale applications Bergqvist & Wårdh [4]. In the direct combustion system, biomass is burned to generate hot flue gases, which is either used directly to provide heat or fed into a boiler to generate steam. But, the most promising and profitable use of this biomass is its use for the electrical energy generation in efficient way, besides this using rice husk in power generation adopting efficient equipment gives very valuable by product Fang et al. [5].

International Journal of Innovative Research in Science, Engineering and Technology

(An ISO 3297: 2007 Certified Organization)

Vol. 5, Issue 1, Januray 2016

II. METHODOLOGY

Analysis of power generation system is of scientific interest and also essential for the efficient utilization of energy resources. The most commonly used basis for analysis of energy conversion process is the first law of thermodynamics; the main performance criteria are commonly power output and thermal efficiency and the second law of thermodynamics, using such concepts as exergy and exergy destructions in order to evaluate the efficiency with the available energy. Exergy analysis provides the tool for the clear distinction between energy losses to the environment and internal irreversibility in the process. Exergy analysis is a methodology for evaluation of the performance of devices and processes, and involves examining the exergy at different points in a series of energy conversion steps. With this information, efficiencies can be evaluated, and the process steps having the largest losses can be identified. For these reasons, the modern method approach to process analysis uses the exergy analysis which provides a more realistic view of the process and a useful tool for engineering evaluation. The objective of this study is to analyze rice husk power plant from energy and exergy perspective. The system was simplified into control volumes with distinct exergy inflows and outflows from each volume representing the different process flows. The processes were approximated to steady or quasi steady- state flow conditions. The desired exergy output was compared to the necessary exergy input. A project layout was designed and schematic flow diagrams were drawn for the system and the subsystems. Equations for analysis of each subsystem were derived. By inputting the real operation and/or design parameters, the exergy balance and exergy performance evaluation were performed.

III. THEORY AND SYSTEM DESCRIPTION

The rice husk power plant has a total installed power capacity of 1.5 MW. The rice mill cogeneration has capacity of 576 tons paddy/day. The generated electricity is supplied to the heat processes in the mill, and the surplus electricity is exported to the grid. Two cases of the study: thermal-match and rice husk-match of different energy utilization are considered for an evaluation of power plants to meet different demand categories. The thermal match can produce electricity and thermal heat for the processes, has been designed based on the topping cycle cogeneration with back-pressure turbine, and as much as the rice husk fuel can be available, the rice husk match can produce surplus electricity. Results show that the rice husk-match cogeneration is more economically feasible than the thermal-match cogeneration. To drive the turbine at inlet pressure of 2.5 MPa and inlet temperature of 400⁰C, 18 ton/h superheated steam is produce through boiler. The turbine can generate electricity of 943 kW in thermal match case and 1,432 kW in rice husk match case. Results of the study also show that rice husk-match cogeneration is more profitable than the thermal match cogeneration. Figure 1 shows the schematic diagram of the rice husk power plants for the thermal match process. The thermal match process defined by the energy consumption is based on heating process requirement.

International Journal of Innovative Research in Science, Engineering and Technology

(An ISO 3297: 2007 Certified Organization)

Vol. 5, Issue 1, Januray 2016

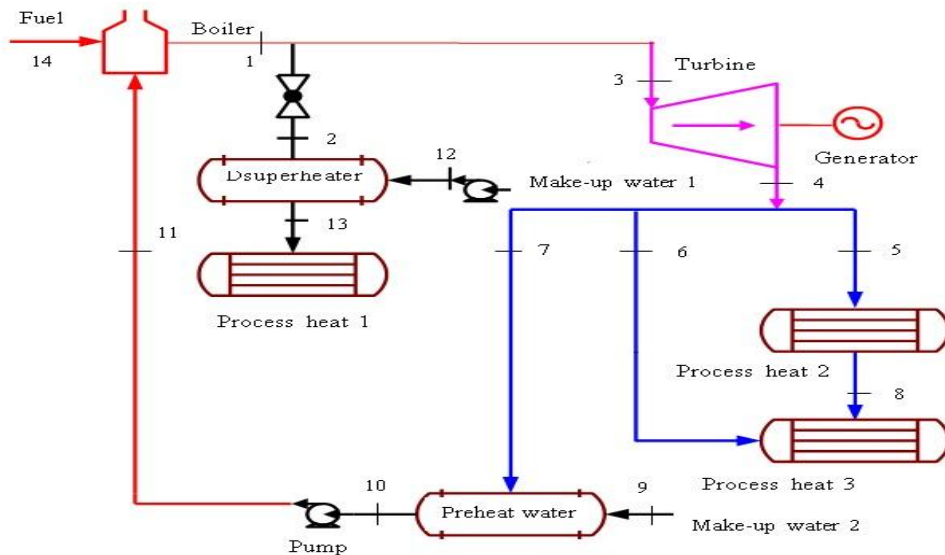

Figure 1 Schematic diagram of rice husk power plant based on the thermal match

Figure 2 shows the schematic diagram of the rice husk power plants for the rice husk match process. The rice husk match process defined by the electricity can be produced as much as the rice husk is available.

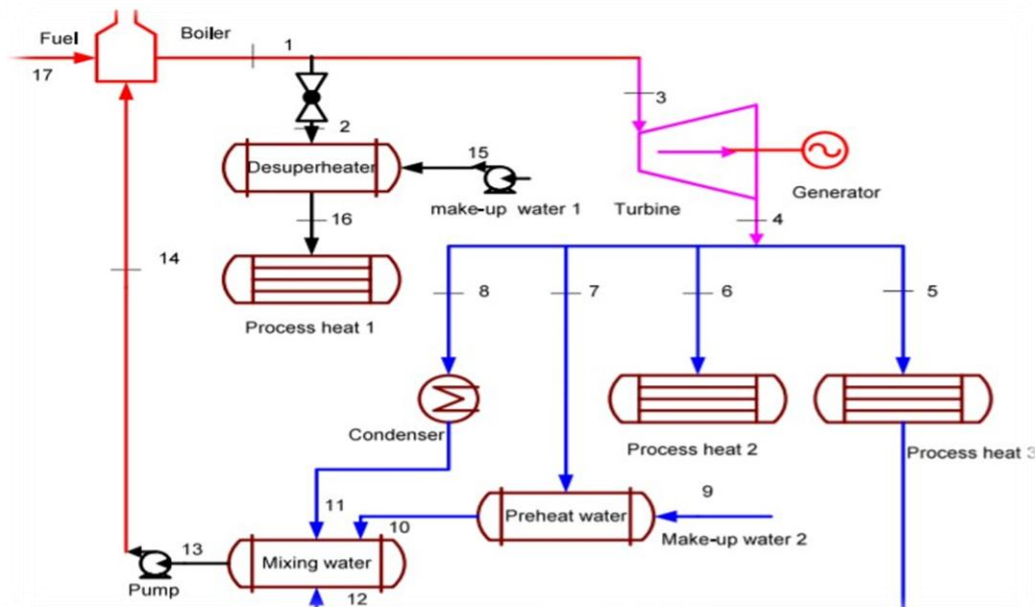

Figure 2 Schematic diagram of rice husk power plant based on rice husk match

Table 1 shows the operating conditions of rice husk cogeneration power plant.

International Journal of Innovative Research in Science, Engineering and Technology

(An ISO 3297: 2007 Certified Organization)

Vol. 5, Issue 1, Januray 2016

Table 1 Operating conditions of the rice husk power plant

Operating condition	Thermal match	Rice husk match
Mass flow rate of fuel (kg/s)	0.8722	1.2405
Steam flow rate (kg/s)	3.18	4.53
Steam temperature (⁰ C)	400	400
Steam pressure (MPa)	2.5	2.5
Max. Turbine capacity (MW)	1	1.5
Electrical power output (MW)	0.943	1.432

Source: Sanit Athasart [19]

Rice husk and coal properties based on proximate and ultimate analyses are compared in Table 2 and Table 3.

Table 2 Proximate analysis (%) of rice husk and compares with coal

Parameters	Rice husk	Bituminous coal
Fixed carbon	20.1	38.92
Volatile matter	55.6	32.20
Moisture	10.3	24.69
Ash	14.0	4.19

Table 3 Ultimate analysis (%) of rice husk and compares with coal

Parameters	Rice husk	Bituminous coal
C	38.0	52.71
H	4.55	3.04
O	32.4	13.08
N	0.69	1.11
S	0.06	1.18
Higher heating value (MJ/kg)	14.980	24.5
Lower heating value (MJ/kg)	12.340	-

Source: Therdyothin A. and Wibulswas P. [18]

IV. ENERGETIC AND EXERGETIC PERFORMANCE ANALYSIS

Energy performance analysis is based on the first law of thermodynamics; the main performance criteria are commonly power output and thermal efficiency [6,7]. The parameters are also decisive performance criteria in economic analysis of power plants [8, 9]. Exergy performance analysis is based on the second law of thermodynamics. Exergy destruction is the measure of irreversibility that is the source of performance loss. Therefore, an exergy analysis assessing the magnitude of exergy destruction identifies the location, the magnitude and the source of thermodynamic inefficiencies in a thermal system [10]. Mass, energy, and exergy balance for any control volume at steady state with negligible potential and kinetic energy changes can be expressed [11-15].

4.1 Energetic Performance Analysis: Energy performance analysis is based on the first law of thermodynamics the main performance criteria are commonly power output and thermal efficiency. From mass and energy balance equation of steady flow energy equation (SFEE), the power output of steam turbine is calculated.

$$\dot{W}_T = \sum \dot{m}_i h_i - \sum \dot{m}_e h_e \tag{1}$$

$$\sum \dot{m}_i = \sum \dot{m}_e \tag{2}$$

$$\dot{W}_T = \dot{m}_{in}(h_{in} - h_1) + (\dot{m}_{in} - \dot{m}_1)(h_1 - h_2) + (\dot{m}_{in} - \dot{m}_1 - \dots - \dot{m}_n)(h_n - h_{out}) \tag{3}$$

Where, the subscripts of 1, 2, ..., n represent the number of steam extractions in steam turbine.

International Journal of Innovative Research in Science, Engineering and Technology

(An ISO 3297: 2007 Certified Organization)

Vol. 5, Issue 1, Januray 2016

$$\dot{Q} - \dot{W} = \sum \dot{m}_e h_e - \sum \dot{m}_i h_i \quad (4)$$

As internal power consumption in the plants, the calculation of pump power can be simply given as following:

$$\dot{W}_P = \frac{\dot{m}(h_{out} - h_{in})}{\eta_p} \quad (5)$$

Here η_p is the efficiency of pump.

Net electrical power output is given by:

$$\dot{W}_{Net} = \sum \dot{W}_T - \sum \dot{W}_P \quad (6)$$

From energy balance at feed water heater:

$$(\dot{m}_s h_s)_{in} + (\dot{m}_{fw} h_{fw})_{in} = (\dot{m}_s h_s)_{out} + (\dot{m}_{fw} h_{fw})_{out} \quad (7)$$

Where, "s" and "fw" of the subscripts represent steam and feed water.

The total required heat energy in the boiler can be determined from:

$$\dot{Q}_B = \frac{[\dot{m}_{sh}(h_{sh,out} - h_{sh,in}) + \dot{m}_{rh}(h_{rh,out} - h_{rh,in})]}{\eta_B} \quad (8)$$

Where, η_B indicate the boiler efficiency and the subscripts "sh" and "rh" indicate superheated and reheat condition, respectively. " \dot{m}_f " is the mass flow rate of fuel (kg./s) and it can be calculated from:

$$\dot{m}_f = \frac{\dot{Q}_B}{LHV} \quad (9)$$

Where, "LHV" is lower heating value of fuel.

Thermal efficiency of the power plants can be calculated as follows:

$$\eta_{th} = \frac{\dot{W}_{Net}}{\dot{m}_f LHV} \quad (10)$$

4.2 Exergetic Performance Analyses: For control volume of any plant component at steady-state conditions, a general equation of exergy destruction rate derived from the exergy balance can be given as,

$$\dot{E}x_D = \sum (\dot{E}x)_{in} - \sum (\dot{E}x)_{out} + \left[\sum \dot{Q} \left(1 - \frac{T_0}{T}\right)_{in} - \sum \dot{Q} \left(1 - \frac{T_0}{T}\right)_{out} \right] \pm \dot{W} \quad (11)$$

Where, the first term $\sum (\dot{E}x)_{in}$ represent exergy of steam at entering and second term $\sum (\dot{E}x)_{out}$ represent exergy of steam at leaving in the control volume. The third term $\sum \dot{Q} \left(1 - \frac{T_0}{T}\right)_{in}$ and the fourth term $\sum \dot{Q} \left(1 - \frac{T_0}{T}\right)_{out}$ are represents exergy related to heat transfer at entering and leaving respectively. The " T_0 " is the ambient temperature of the systems and " \dot{Q} " represents heat transfer rate across the boundary of the system at a constant temperature "T", and

the last term \dot{W} is the work transfer to or from the control volume.

The exergy transfer by heat (\dot{X}_{out}) at temperature T is given by,

$$X_{heat} = \sum \dot{Q} \left(1 - \frac{T_0}{T}\right) \quad (12)$$

And the specific exergy is given by heat required,

$$\psi = (h - h_0) - T_0(s - s_0) \quad (13)$$

Then the total exergy rate associated with a fluid stream becomes,

$$\dot{E}x = \dot{X} = \dot{m}\psi = \dot{m}[(h - h_0) - T_0(s - s_0)] \quad (14)$$

Where, "h" and "s" represent specific enthalpy and entropy, respectively.

Total exergy destruction rate in the plant can be determined as sum of exergy rate of components:

$$\dot{E}x_{D,total} = \sum \dot{E}x_{D,i} = \dot{E}x_{D,B} + \dot{E}x_{D,T} + \dot{E}x_{D,C} + \dot{E}x_{D,P} + \dot{E}x_{D,H} \quad (15)$$

The exergy efficiency can be given for whole power plant as:

$$\eta_{Ex} = \frac{\dot{W}_{Net}}{\dot{m}_{fuel} ex_{fuel}} \quad (16)$$

International Journal of Innovative Research in Science, Engineering and Technology

(An ISO 3297: 2007 Certified Organization)

Vol. 5, Issue 1, Januray 2016

V. RESULT AND DISCUSSION

Table 4 Energy and Exergy analysis of rice husk cogeneration power plant for thermal match at $T_0=303.15\text{ K}$, $P_0=101.35\text{ kPa}$.

Point	T ($^{\circ}\text{C}$)	P (MPa)	Flow rate (kg/s)	h (kJ/kg)	s (kJ/kgK)	Energy (kW)	Exergy (kW)
0	30	0.101		125.9	0.437	-	-
1	400	2.5	3.18	3229	7.015	9867.86	3526.55
2	389	1.1	0.58	3229	7.384	1799.8	578.33
3	400	2.5	2.6	3229	7.015	8068.06	2883.35
4	182.8	0.2	2.6	2836	7.432	7046.26	1532.871
5	182.8	0.2	1.89	2836	7.432	5122.09	1114.26
6	182.8	0.2	0.34	2836	7.432	921.434	200.452
7	182.8	0.2	0.37	2836	7.432	1002.74	218.14
8	120	0.2	1.89	503.7	1.528	714.04	88.95
9	30	0.101	2.81	125.9	0.437	0	0
10	105	0.2	3.18	440.1	1.363	999.16	106.48
11	105	2.5	3.18	441.9	1.361	1004.884	114.13
12	30	2.2	0.084	127.8	0.436	0.16	0.185
13	184.1	1.1	0.667	2782	6.554	1763.65	532.35

The mass flow rate of rice husk fuel of the power plant shown in Figure 1 is 0.8722 kg/s. The energy balance in thermal match cogeneration is shown in Table 5.

Table 5 Energy balance of rice husk cogeneration on thermal match

Components	Heat loss (kW)	Percentage (%)
Boiler	1899.97	17.65
Net power output	943	8.76
Heat process 1	1763.65	16.39
Heat process 2	4408.05	41
Heat process 3	1635.474	15.2
Desuperheater	36.31	0.34
Preheat water	3.58	0.033
Pump (make up water 1)	0.16	0.002
Pump (water feed)	5.724	0.053
Turbine	67.03	0.6
Total	10,762.95	100

The values of Exergy destruction and Exergy efficiency of main components in thermal match cogeneration power plant are calculated in Table 6.

International Journal of Innovative Research in Science, Engineering and Technology

(An ISO 3297: 2007 Certified Organization)

Vol. 5, Issue 1, Januray 2016

Table 6 Exergy destruction and efficiency of rice husk cogeneration in thermal match

Components	Exergy destruction (kW)	Exergy destruction (%)	Exergy efficiency (%)
Boiler	7888.68	71.34	30.2
Turbine	328.68	2.97	75.66
Heat process 1	532.35	4.81	-
Heat process 2	1852.74	16.76	-
Heat process 3	289.4	2.62	-
Desuperheater	46.165	0.42	78.62
Preheat water	111.6	1.01	48.8
Pump (make up water 1)	0.185	0.002	76.34
Pump (water feed)	7.65	0.069	95.47
Total	11057.45	100.00	32.61

Table 7 Energy and Exergy analysis of rice husk cogeneration power plant for rice husk match at
 $T_0 = 303.15 \text{ K}$, $P_0 = 101.35 \text{ kPa}$.

Point	T ($^{\circ}\text{C}$)	P (MPa)	Flow rate (kg/s)	h (kJ/kg)	s	(kJ/kgK)	Energy (kW)	Exergy (kW)
0	30	0.101		125.9		0.437	-	-
1	400	2.5	4.53	3229		7.015	14057.04	5023.68
2	389	1.1	0.583	3229		7.384	1809.11	585.31
3	400	2.5	3.947	3229		7.015	12247.94	4377.14
4	182.8	0.2	3.947	2836		7.432	10696.77	2327.02
5	182.8	0.2	1.89	2836		7.432	5121.78	1114.28
6	182.8	0.2	1.58	2836		7.432	4281.7	931.52
7	182.8	0.2	0.1388	2836		7.432	376.14	81.83
8	182.8	0.2	0.338	2836		7.432	915.96	199.27
9	30	0.101	0.922	125.9		0.437	0	0
10	105	0.2	1.06	440.2		1.363	333.04	35.6
11	120	0.2	1.58	503.7		1.528	596.93	74.36
12	120	0.2	1.89	503.7		1.528	713.73	88.95
13	116.5	0.2	4.53	488.8		1.49	1643.7	198.91
14	116.5	2.5	4.53	490.5		1.488	1651.4	208.33
15	30	2.2	0.084	127.8		0.4362	0.16	0.18
16	184	1.1	0.667	2782		6.554	1771.62	534.75

The rice husk cogeneration was analyzed at ambient condition of 30°C and 0.101 MPa. The mass flow rate of rice husk fuel of the power plant shown in Figure 2 is 1.2405 kg/s. The energy balance in rice husk match cogeneration is shown in Table 8.

International Journal of Innovative Research in Science, Engineering and Technology

(An ISO 3297: 2007 Certified Organization)

Vol. 5, Issue 1, Januray 2016

Table 8 Energy balance of rice husk cogeneration on rice husk match

Components	Heat loss (kW)	Percentage (%)
Boiler	2902.13	18.96
Net power output	1432	9.35
Heat process 1	1771.62	11.57
Heat process 2	4281.7	27.97
Heat process 3	4408.05	28.8
Condenser	319.03	2.08
Desuperheater	37.65	0.25
Preheat water	43.3	0.28
Pump (make up water 1)	0.16	0.001
Pump (water feed)	7.7	0.05
Turbine	104.63	0.68
Total	15307.97	100

The values of Exergy destruction and Exergy efficiency of main components in rice husk match cogeneration power plant are calculated in Table 9.

Table 9 Exergy destruction and efficiency of rice husk cogeneration in rice husk match

Components	Exergy destruction (kW)	Exergy destruction (%)	Exergy efficiency (%)
Boiler	11104.73	77.51	30.25
Turbine	498.95	3.48	75.66
Heat process 1	534.755	3.73	-
Heat process 2	931.52	6.5	-
Heat process 3	1025.33	7.16	-
Condenser	124.91	0.87	27.53
Desuperheater	50.735	0.36	91.3
Preheat water	46.23	0.32	43.5
Pump (make up water 1)	0.18	.001	71.34
Pump (water feed)	9.42	0.066	96.47
Total	14326.76	100	26.42

The exergy losses are also shown in Figure 3 and Figure 4 of thermal match and rice husk match, respectively. It can be concluded that the process heat consumes most of energy in the rice husk cogeneration. It means that the cogeneration needs much thermal heat in the processes. Exergy destruction and exergy efficiencies are summarized in Table 6 and Table 9. For all components presented in the power plant of both cases of rice husk cogeneration, it was found that the exergy destruction in the boiler is dominant over all other irreversibility in the cycle. The exergy destruction in boiler is accounted for 71.34% of total system exergy destruction in thermal match and 77.51% in rice husk match. The exergy destruction in the condenser is only 0.87%. The real loss is primarily back to the boiler where entropy was produced. Contrary to the first law analysis, the second law analysis demonstrates that significant improvements exist in the boiler system rather than in the condenser. In order to quantify the exergy of the systems, both system and the surrounding must be specified. It is assumed that the environment does not significantly change in properties of the process. The dead state is the state of a system in which it is in

International Journal of Innovative Research in Science, Engineering and Technology

(An ISO 3297: 2007 Certified Organization)

Vol. 5, Issue 1, Januray 2016

equilibrium with its surroundings. The calculated exergy efficiency of power cycle in thermal match and rice husk match is 32.61% and 26.42 % respectively. It is relatively low in the case of rice husk match because the exergy loss and the exergy destruction in boiler are much more than in the thermal match cogeneration. The reference environment state is irrelevant to calculation of a change in thermodynamic properties by the first law analysis. However, it is expected that, in the second law analysis, the dead state has some effects on the results of exergy.

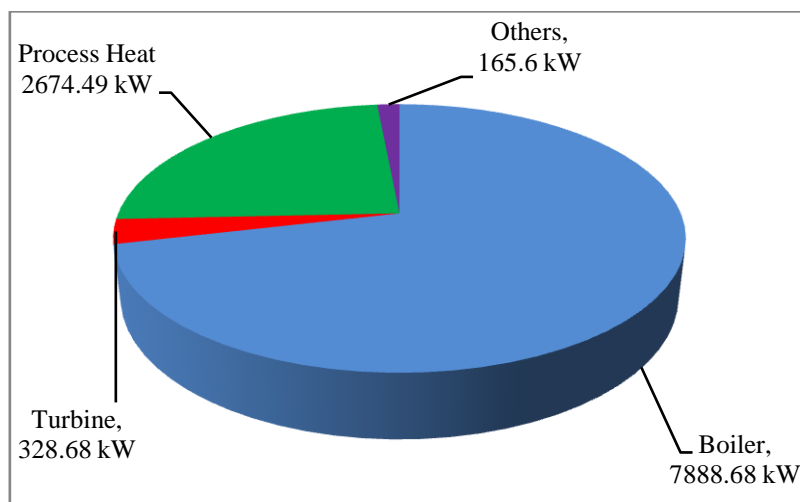

Figure 3 Exergy diagram of thermal match cogeneration

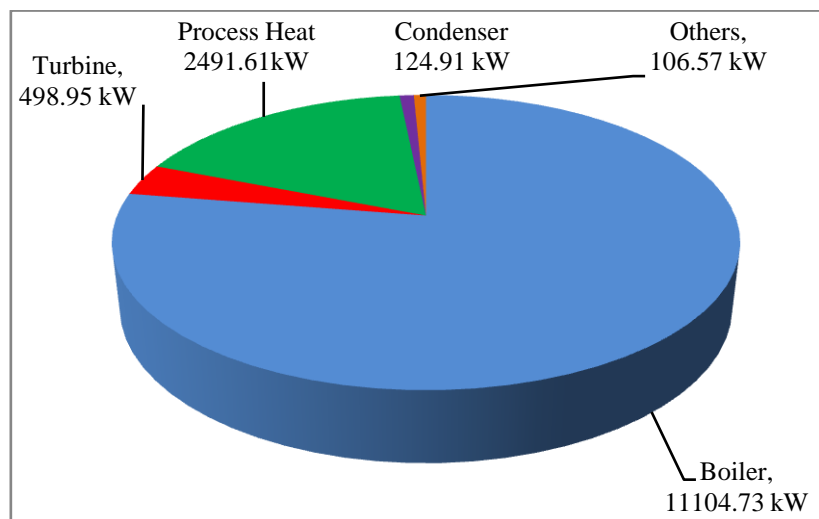

Figure 4 Exergy diagram of rice husk match cogeneration

VI. CONCLUSION

In this study, energy and exergy analyses as well as the effects of varying the reference ambient temperatures on the exergy analysis of an actual rice husk cogeneration are presented. In the considered power plant, exergy analysis of the rice husk cogeneration power plant shows that the exergy destruction in boiler is accounted for 71.34% of total system exergy destruction in thermal match and 77.51% in rice husk match. The exergy losses in turbine of both cases are around 3%. It can be concluded that the boiler is the major source of irreversibility in the rice husk

International Journal of Innovative Research in Science, Engineering and Technology

(An ISO 3297: 2007 Certified Organization)

Vol. 5, Issue 1, January 2016

cogeneration power plant. In thermal match case, the calculated exergy efficiency of cogeneration is 32.61% while in the rice husk match case, the exergy efficiency is 26.42%. Both are acceptable because this rice husk cogeneration plant not only generates electricity but also requires so much energy in its thermal processes, and the calculation of output exergy efficiency is based on both electricity and heat process output. In case of rice husk match, the exergy efficiency is relatively low because of the exergy destruction in boiler is much more than in the thermal match case and it gives the guideline for engineers on process improvement. It also means that its power to heat ratio is too low. Although the exergy efficiency of each component in the system changes with ambient temperature, the changes are found to be insignificant in this study.

REFERENCES

- [1] Kumar, A., Mohanta, K., Kumar, D. & Parkash, O., Properties and Industrial Applications of Rice husk: A review: International Journal of Emerging Technology and Advanced Engineering, 2(10), pp. 86-90, 2012.
- [2] Hwang, C.-L., Bui, L. A.-T. & Chen, C.-T., Effect of rice husk ash on the strength and durability characteristics of concrete. Construction and Building Materials, Volume 25, p. 3768–3772, 2011.
- [3] Pham, T. M., Kurisu, K. H. & Hanaki, K., Greenhouse gas emission mitigation potential of rice husks for An Giang province, Vietnam. Biomass and Bioenergy, Volume 35, pp. 3656-3666, 2011.
- [4] Bergqvist, M. & Wårdh, S., A Technical and Economic Assessment of the Potential of Utilising Rice Husk for Heat and Power Production in Vietnam. Gothenburg: Chalmers University of Technology, 2007.
- [5] Fang M. Yang L. Chen G. Shi Z. Luo Z. and Cen K., Experimental study on rice husk. UNEP, Converting Waste Agricultural Biomass into a Resource-Compendium of Technologies, Osaka/Shiga: UNEP DTIE - International Environmental Technology Centre (IETC), 2009.
- [6] Alonso Pippo W., Garzone P., Cornacchia G., Agro-industry sugarcane residues disposal: The trends of their conversion into energy carriers in Cuba. Waste management, 27, pp869-885, 2007.
- [7] A. K. Srivatsav, Selection of steam parameters for cogeneration, in: Process of Cogeneration in India 96, New Delhi, TERI, 1996, pp158–162, 1996.
- [8] Pallav Purohit, Axel Michaelowa, CDM potential of bagasse cogeneration in India, Energy policy, 35, pp4779-4798, 2007.
- [9] Subhes C. Bhattacharyya, Dang Ngoc Quoc Thang, Economic buy-back rates for electricity from cogeneration: Case of sugar industry in Vietnam, Energy, 29, pp10391051, 2004.
- [10] T.J. Kotas, The Exergy method of Thermal plant Analysis, Butterworth, London, 1985.
- [11] S.C. Kamate, P.B. Gangavati, Exergy analysis of cogeneration power plant in sugar industries, Applied Thermal Engineering, 2008.
- [12] J.Raghu Ram Ram, Rangan Banerjee, Energy and Cogeneration targeting for sugar factory, Applied Thermal Engineering, 23, pp1567-1575, 2003.
- [13] Mehmet Kanoglu, Ibrahim Dincer, Performance assessment of cogeneration plants, Energy Conversion and Management, 50, pp76-81, 2009.
- [14] Walfrido Alonso-Pippo, Sugarcane energy use: The Cuban case, Energy policy, 36, pp. 2163-2181, 2008.
- [15] P. C. Lobo, Economics of Alternative sugar cane milling option, Applied Thermal Engineering, 27, pp1405-1413, 2007.
- [16] Natarajan E., Nordin A., Roa A.N., Overview of combustion and gasification of rice husk in fluidized-bed reactors, Biomass Bioenergy, 14, pp533-546, 1998.
- [17] Nussbaumer T., Combustion and co-combustion of biomass: fundamental, technologies, and primary measure for emission reduction, Energy fuel, 17, pp1510-1521, 2003.
- [18] Therdyothin A. and Wibulsawas P., Feasibility of cogeneration using husk as fuel, Proceeding of international conference on energy resource and management, Beijing, pp451-460, 1998.
- [19] Sanit Athasart, "Cogeneration potential of parboiled rice mill in Thailand" A Master thesis of Engineering, Department of Energy Management Technology, King's Mongkut University of Technology, 2002.