

# Real Time Obstacle Detection and Automatic Headlight Dimmer for Automobiles

Farooque Abdullah<sup>1</sup>, Brindha<sup>2</sup>, Divya<sup>3</sup>, Anitha<sup>4</sup>, Nimisha<sup>5</sup>U.G. Student, Department of Electronics and Communication Engineering, Sri Eshwar Engineering College,  
Coimbatore, India<sup>1234</sup>Assistant Professor, Department of Electronics and Communication Engineering, Sri Eshwar Engineering College,  
Coimbatore, India<sup>5</sup>

**ABSTRACT:** The number of the accidents that occur in the world increases every year but the amount of fatalities has decreased due to new technology developed by the automobile industry. However the only way to save far more lives is to keep cars from smashing into each other in the first place. In this paper, a system is presented to avoid accidents caused by careless driving of the driver. This system warns the driver when it finds obstacles on its path which aids the driver in preventing accidents. A simple method is suggested, to improve the safety of the vehicle by using ultrasonic sensors for getting a picture of the obstacles in the path of the vehicle. Another method is suggested to automate the head lamps of the vehicle from high beam to low beam by sensing the intensity of light from opposite vehicle. These techniques increase the comfort and safety of night driving to a large extent.

**KEYWORDS:** Automobiles, Headlight dimmer, Ultrasonic sensor, Obstacles.

## I. INTRODUCTION

Microcontroller is the heart of the device which handles all the sub devices connected across it. We have used as microcontroller. It has flash type reprogrammable memory. It has some peripheral devices to play this project perform. It also provides sufficient power to inbuilt peripheral devices. We need not give individually to all devices. The peripheral devices also activates as low power operation mode. These are the advantages are appear here.

Present industry is increasingly shifting towards automation. Two principle components of today's industrial automations are programmable controllers and robots. In order to aid the tedious work and to serve the mankind, today there is a general tendency to develop an intelligent operation. PIC

## II. RELATED WORK

[1]. OBJECT detection and tracking are important in many computer vision applications. In this paper, we propose a purely vision based approach for real time obstacle detection for an automotive vehicle designed to provide automotive safety purpose. Our proposed system uses as input the video streams from a synchronized, forward-looking camera. To analyze this data, the system combines visual object detection and warning system. These systems consist of low cost USB camera, warning system device and computer system. USB camera is most suitable because of its low cost and ranging capability. According to the present invention, the object scene captured by low cost camera which is located at the head of an automotive vehicle. Camera captured the images as RGB images which is converted in to the grayscale images by some image processing algorithms. These grayscale images are used to process the object scene, for predicting that an obstacle is approaching the vehicle using MATLAB environment. As a result, Warning system connected to the microcontroller which in turn will be connected to the computer via serial port, provides an alert message and indication to the driver of the automotive vehicle on recognizing the object. According to this project the obstacle passing through the vehicles is surely and stably detected and avoid any traffic accident. In this work, the

# International Journal of Innovative Research in Science, Engineering and Technology

(An ISO 3297: 2007 Certified Organization)

Vol. 5, Issue 3, March 2016

computer program for image processing and for alerting, all are implemented in MATLAB environment. The purpose of this work is to reduce driver error by providing information about the task situation using obstacle detection.

[2]. The requirement of headlight is very common during night travel. The same headlight which assists the driver for better vision during night travel is also responsible for many accidents that are being caused. The driver has the control of the headlight which can be switched from high beam (bright) to low beam (dim). The headlight has to be adjusted according to the light requirement by the driver. During pitch black conditions where there are no other sources of light, high beam is used to. On all other cases, low beam is preferred. But in a two-way traffic, there are vehicles plying on both sides of the road. So when the bright light from the headlight of a vehicle coming from the opposite direction falls on a person, it glares him for a certain amount of time. This causes disorientation to that driver. This discomfort will result in involuntary closing of the driver's eyes momentarily. This fraction of distraction is the prime cause of many road accidents. The prototype that is has been designed, reduces this problem by actually dimming down the bright headlight of our vehicle to low beam automatically when it senses a vehicle at close proximity approaching from the other direction. The entire working of the dimmer is a simple electronic circuitry arrangement which senses and switches the headlight according to the conditions required.

### III. HEADLIGHT BEAMS AND ULTRASONIC SENSOR

The headlight of vehicles is fitted with two bulbs. One bulb is used for high beam and the other for the low beam. On an average, in India, the requirement of the headlight is essential from 6.00 pm till 5.00 am. It is most essential during late night travels. The headlight can be switched between the bright and dip modes by the driver using a switch. The bright mode is used when there are no other sources of light on the streets to aid with driving. Long highways, a pitch black street with no lights are the ideal locations where one would use a bright beam [5]. The dip or the low beam is less intense than the bright beam. It is used under normal night driving conditions. The dip beam is aimed low at the road and gives less range. The high beam has a longer range but very less field coverage. Hence, dip beam is less intense (700 lumens) and high beam has a higher brightness index (1200 lumens) when tested under a standard distance of 50 feet from the vehicle. The high beam since has a longer throw and a higher brightness index, will ultimately fall directly on the eyes of the driver coming on the other side of the traffic. The angle of spread of the dip beam and the high beam is 135 and 15 respectively. This again confirms on their range and spread. A human eye can withstand a brightness of around 1000 lumens when the source is at 20 feet. Hence it is very important to make sure that our vehicle's bright (high) beam does not affect the driver coming from the opposite direction. As it is not possible to reduce the intensity of our headlight, all we have to do is to switch down to the dip beam until the traffic has passed away. This will ensure a safe and a friendly driving on the road during the night.

**Ultrasonic sensors** (also known as **transceivers** when they both send and receive) work on a principle similar to radar or sonar which evaluate attributes of a target by interpreting the echoes from radio or sound waves respectively. Ultrasonic sensors generate high frequency sound waves and evaluate the echo which is received back by the sensor. Sensors calculate the time interval between sending the signal and receiving the echo to determine the distance to an object. This technology can be used for measuring: wind speed and direction (anemometer), fullness of a tank and speed through air or water. For measuring speed or direction a device uses multiple detectors and calculates the speed from the relative distances to particulates in the air or water. To measure the amount of liquid in a tank, the sensor measures the distance to the surface of the fluid. Further applications include: humidifiers, sonar, medical ultrasonography, burglar alarms and non-destructive testing. Systems typically use a transducer which generates sound waves in the ultrasonic range, above 20,000 hertz, by turning electrical energy into sound, then upon receiving the echo turn the sound waves into electrical energy which can be measured and displayed. The technology is limited by the shapes of surfaces and the density or consistency of the material. For example foam on the surface of a fluid in a tank could distort a reading.

# International Journal of Innovative Research in Science, Engineering and Technology

(An ISO 3297: 2007 Certified Organization)

Vol. 5, Issue 3, March 2016

## IV. BLOCK DIAGRAM

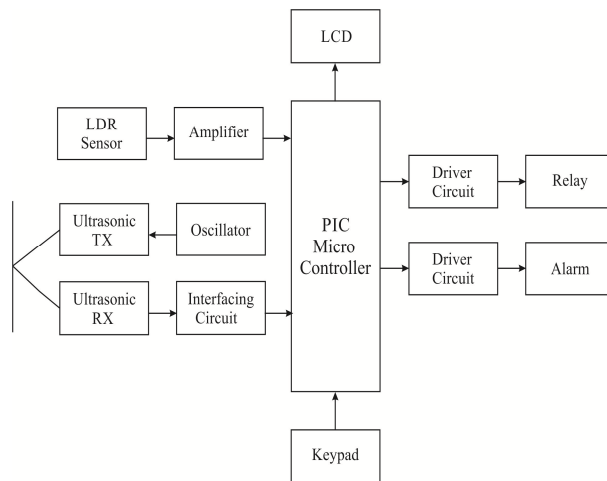

Microcontroller is a general purpose device, which integrates a number of the components of a microprocessor system on to single chip. Here all the components have been connected to the PIC controller. Generally when the system gets ON, the ultrasonic transmitter starts transmitting the waves, and the time value gets started increasing and when it detects any obstacles it gets reflected back and the reflected wave is received by the ultrasonic receiver. Both the values are processed and the buzzer gets ON by the relay. Also it displays the distance between the vehicle and the obstacle in the LCD display. When high beam falls on the LDR of our vehicle from the another vehicle coming in front of us it automatically switches to low beam and to high beam when the vehicle passes by, so that the illuminance can be reduced.

## V. EXPERIMENTAL RESULTS

[1] At normal driving conditions the high beam is switched on (during night time). That is when the system gets on the power supply of 12V and 5V is supplied by the step down transformer. Relay works on the supply of 12V and rest of all the components works of 5V. This figure describes that at normal driving conditions that is when no light from the other vehicle falls on the LDR, the resistance will be low and hence the high beam is switched ON.

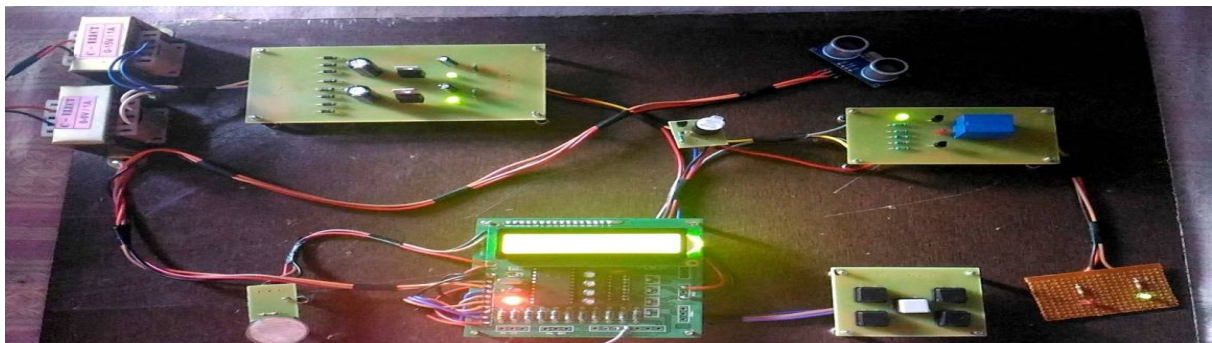

[2] When any vehicle approaches the beam automatically changes to low beam (during night time). That is when the system gets on the power supply of 12V and 5V is supplied by the step down transformer. Relay works on the

## International Journal of Innovative Research in Science, Engineering and Technology

(An ISO 3297: 2007 Certified Organization)

Vol. 5, Issue 3, March 2016

supply of 12V and rest of all the components works of 5V. This figure describes that when any vehicle comes in front of our vehicle the light falls on LDR and the resistance will be high, hence the low beam is switched ON and changes to high beam when the vehicle passes by.

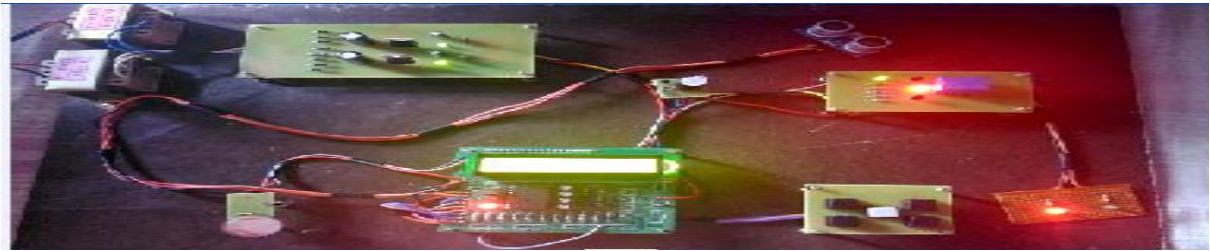

[3] When ultrasonic sensor detects any obstacle the alarm produces sound and the distance between the vehicle and the obstacle is displayed in the LCD display. This figure describes that the transmitter of ultrasonic sensor produces the waves simultaneously the time value starts counting in the controller and when the wave finds any obstacle it is reflected back and reaches to the receiver. And based on the time value the distance is calculated also will be displayed in the LCD display.



### VI. ACKNOWLEDGEMENTS



We thank Mrs. Nimisha, K.R, ME, our project guide for helping and guiding us throughout the entire project and also providing us information about the statistical reports.

### REFERENCES

- 1] Real Time Obstacle Detection For An Automotive Vehicle By Shivani Godha And Pradeep Jain.
- 2] Automatic Headlight Dimmer A Prototype For Vehicles By Muralikrishnan R.
- 3] Obstacle Avoidance With Ultrasonic Sensors By Johann Borenstein And Yoran Koren.
- 4] Automatic High Beam Controller For Vehicles By Mohammad Mahmudul Islam.
- 5] Obstacle Avoiding Robot – A Promising One By Rakesh Chandra Kumar.
- 6] Automatic Dimming Of Headlights Using Vehicle Speed By K. Ashiq Ahamed.

## International Journal of Innovative Research in Science, Engineering and Technology

(An ISO 3297: 2007 Certified Organization)

Vol. 5, Issue 3, March 2016

7]Ultrasonic Sensors In Air By Valentin Magori.

8]Distance Measurement Of An Object Or Obstacle By Ultrasound Sensors Using P89c51rd2 By A.Verma.

### BIOGRAPHY



**Farooque Abdullah.S** was born in Coimbatore,India on 30.09.1993 and completed his schooling in P.K.D.Matriculation Higher Secondary School,Pollachi in the year 2012.Currently pursuing the under graduate course,B.E (Electronics and Communication Engineering) in Sri Eshwar College of Engineering,Coimbatore,India.His areas of interests include Networking and Control systems.



**Brindha.C** was born in Theni,India on 26.03.1995 and completed her schooling from Nadar Saraswathi Higher Secondary School,Theni in the year 2012.Currently pursuing the under graduate course,B.E (Electronics and Communication Engineering) in Sri Eshwar College of Engineering,Coimbatore,India.Her areas of interests include Networking and Embedded systems.



**Divya.T.R** was born in Ooty,India on 10.09.1994 and completed her schooling from Shri Shanthi Vijay Girls Higher Secondary School,Ooty in the year 2012.Currently pursuing the under graduate course,B.E (Electronics and Communication Engineering) in Sri Eshwar College of Engineering,Coimbatore,India.Her areas of interests include Digital Signal Processing and Control systems.



**Anitha.C** was born in Coimbatore,India on 02.06.1995 and completed her schooling from Government Higher Secondary Schoo,Vadasithur,Kinathukadavu in the year 2012.Currently pursuing the under graduate course,B.E (Electronics and Communication Engineering) in Sri Eshwar College of Engineering,Coimbatore,India.Her areas of interests include Electronic circuits and Embedded systems.