

# Design and Analysis of Steel Concrete Composite Beams by using Shear Connectors

K.Sathish Kumar<sup>1</sup>, T. Tamizhazhagan<sup>2</sup>P.G. Student, Department of Civil Engineering, Prist University, Thanjavur, Tamilnadu, India<sup>1</sup>Assistant Professor, Department of Civil Engineering, Prist University, Thanjavur, Tamilnadu, India<sup>2</sup>

**ABSTRACT:** A simple computation procedure is developed to predict the general behaviour of composite beam with shear connector under bending. Different spacing of shear connector should be change cold form sheet considered. The experiments include four series of composite beams tested. The tests reported were used to ascertain the flexural strength of the beams and to validate the theoretical predictions. Companion specimens of concrete cylinders and cubes were tested for compressive strength and elastic modulus properties. The section was then exposed to bending, and the change in the behaviour was noticed. The effect of a wide range of important parameters was studied on composite beams accompanied by bending.

**KEYWORDS:** steel concrete, composite beam, shear connectors

## I. INTRODUCTION

Though Concrete is a versatile construction material having several advantages due to its compressive strength and mouldable shape, but it has its own tensional limitation and poor ductility. Ductility is an important characteristic of a structure to resist earthquake, impact and blast loading. Steel has excellent ductile property. Hence a judicious combination of structural steel and concrete utilizing the strength possessed by them and suppressing their weakness resulted in the composite construction. A structural member composed of two or more dissimilar materials joined together to act as a unit is referred as composite structure. Joining two dissimilar materials to form a composite member does not only combine the collective strengths of the two materials, forming a union between relevant materials actually enhances their physical characteristics and makes the composite stronger than the sum of their strengths. In order to design the structural member with maximum efficiency and minimum cost, steel-concrete composite construction is adopted. It is a powerful construction concept in which compressive strength of concrete and the tensile strength of steel are almost effectively used. Steel and the concrete have almost the same thermal expansion apart from an ideal combination of strength. Hence, these essential different materials are completely compatible and complementary to each other.

**Figure-1: CSCC Beam**



**Figure-2: Stud Shear Connector**

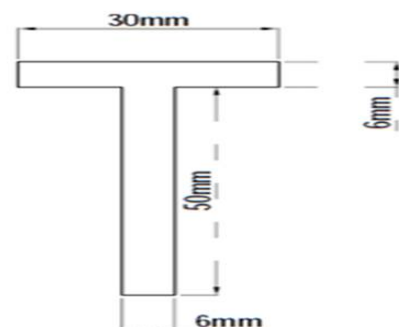

# International Journal of Innovative Research in Science, Engineering and Technology

(An ISO 3297: 2007 Certified Organization)

Vol. 5, Issue 3, March 2016

As a result of experimental investigation carried out in the past by many researchers with different ways of bonding between steel and concrete, an innovative study has been done in this project to understand the behaviour of concrete beam shuttered with cold formed steel sheet which acts as a composite beam by means of shear connectors and bracings viz. 'Confined Steel Concrete Composite Beam' (CSCC Beam). This is the new idea to the composite structure world. And this can be a replacement for hot rolled steel beams or RCC beams in small to medium sized building. The cold formed steel sheet is bonded to surface of concrete by means of shear connectors. Stud shear connectors are used to take up the bond between sheet and concrete. The passive confinement by the cold formed sheet in the sides and bottom influences the strength and ductility of the system. These beams are simple to fabricate and provides very good confinement of concrete. One of the most important parts of a composite beam is the fixing points of shear connectors between the two materials. The correct connection of the two parts of the composite allows the materials to act as a unit and gives the composite beam its inherent strength. A composite beam is constructed generally by casting a reinforced concrete slab on the top of the steel beam. Composite action between the steel and the concrete is achieved by means of mechanical connectors by the effective transfer of shear at the interface between concrete and sheet elements. These connectors are generally dubbed as 'shear connectors'.

Therefore in this study, the flexural and torsional behaviour and strength characteristics of composite beams, effects of combined bending & torsion on the strength characteristics of Composite beams and the mechanical properties of composite beam with shear connector were investigated.

## II. MATERIAL AND MIX PROPORTION

In view of the complex nature of the problem of studying the interaction between torsional and flexural strength of the composite beam, an approach is made to conduct the experiments to observe the behaviour of the beams under combined bending and torsion. Based on the observations from the experiments, equations are developed for the interaction and the validity is finally established by the comparison of experimental and theoretical results

- ⇒ Casting beam size 2300x150x230 mm.
- ⇒ More number of beams for composite beams specimens are planned to be cast
- ⇒ M30 grade of concrete will be adopted.
- ⇒ Spacing of shear connectors will be varied as 5cm, 7.5cm and 10cm
- ⇒ Percentage of conventional reinforcement will be provided in minimum quantity. i.e.(0% , 0.3%, 0.6% of the cross sectional area of beam)

In order to conduct the analysis of confined steel concrete composite beam (CSCC Beams) the knowledge about the material properties, mix adopted and compressive strength is essential. Hence experiments were conducted on materials, specimen of concrete cubes and cold formed sheet to understand the behaviour of materials under composite action. Cement: Cement conforming to IS 1489 (part-1):1991, Birla Plus, Premium composite 53 grade cement is considered for the concrete mix. Fine Aggregate: The fine aggregates used for the entire specimen were natural river sand complying with the requirements of IS 383:1970. Sieve analysis was conducted using 2.36mm and it was found that sand was conforming to zone-II grading. Coarse Aggregate: Coarse Aggregate used for making the concrete was as per Indian Standards specifications 20mm. Water: Potable water was used for mixing concrete and for the curing of cast specimens. Reinforcement Bars: Fe 415 bars are used at bottom to take care of temperature effects and their properties were tested in the computerized UTM of 100 tonnes capacity.

Mix Ratio as per IS method is adopted for the design mix. Plain concrete cubes, cylinders, plain beams of standard size were cast, cured and tested in UTM and the results are tabulated. The adopted concrete grade was M30.

## III. EXPERIMENT AND RESULTS

Ordinary Portland cement locally available crushed aggregates of 20 mm maximum size and river sand passing through 2.36mm were used in making the concrete. Within the standard moulds the concreting was done. After 24 hours from casting, the specimens were demoulded and cured for 28 days using curing tank.

## International Journal of Innovative Research in Science, Engineering and Technology

(An ISO 3297: 2007 Certified Organization)

Vol. 5, Issue 3, March 2016

Table-1: Compressive Strength of Plain Concrete Cubes					
S.No	Cube series	Mix ratio	W/C ratio	Load (KN)	$f_{ck}$ (N/mm <sup>2</sup> )
1	C1 to C8	1:1.6:2.8	0.45	564	25.07
2				603	26.8
3				630	28.04
4				631	28.08
5				650	28.89
6				656	29.16
7				657	29.24
8				674	29.96

The table-1 shows the compressive strength of the test results. And it was identified that the cube series c8 has the higher compressive value. There is a gradual increase in the compressive strength throughout the specimen series.

Table-2: Split Tensile strength of Cylinders					
S.No	Cylinder series	Mix ratio	W/C ratio	Load (KN)	$\sigma_{st}$ (N/mm <sup>2</sup> )
1	CY1 to CY8	1:1.6:2.8	0.45	171.7	2.43
2				178.8	2.53
3				180.9	2.56
4				182.3	2.58
5				185.9	2.63
6				188	2.66
7				192.9	2.73
8				197.9	2.8

From the table-2 the split tensile strength of the cylinder specimens were known. Similar to compressive strength the split tensile strength of the cylinder series 8 has the highest value. From the table-3 the flexural strength of the concrete beams were identified. Series 8 has the higher flexural strength value. When comparing the specimen results and it was found that the 8 achieves the best result. This is relatively in all the mechanical properties of the concrete.

## International Journal of Innovative Research in Science, Engineering and Technology

(An ISO 3297: 2007 Certified Organization)

Vol. 5, Issue 3, March 2016

Table-3: Flexural strength of Concrete Beams					
S. No	Beam series	Mix ratio	W/C ratio	Load (KN)	$f_{ck}$ (N/mm <sup>2</sup> )
1	B1 to B8	1:1.6:2.8	0.45	14.72	7.36
2				14.96	7.48
3				15.23	7.62
4				15.35	7.68
5				15.64	7.82
6				16	8
7				16.13	8.07
8				16.27	8.14

### IV. CONCLUSION

From the results of the above experimental investigation it was identified that the composite beams with shear connectors have achieved higher strength properties. Hence this study leads to try out many composite beams in structural beams to withstand the load properties. The other advantages in using steel-concrete composite section are:

- ⇒ Most effective utilization of materials like concrete in compression and steel in tension.
- ⇒ High ductility of steel leads to better seismic resistance of the composite section.
- ⇒ Steel component has the ability to absorb the energy released due to seismic forces.
- ⇒ Ability to cover large column free area.
- ⇒ Faster construction by utilizing rolled and/or prefabricated components.
- ⇒ Keeping span and loading unaltered, smaller sections are required compared to non-composite construction.
- ⇒ Minimum disturbance to traffic in bridge construction.

### REFERENCES

- [1] Ansurian, P. (1981), "Experiments on Continuous Composite Beams," Proc. Inst. Civ.Engg. Part 2, 71, 25-51.
- [2] ArivalaganSoundararajan , KandasamyShanmugasundaram. (2008),"Flexural Behavior of Steel Hollow Beams," J. Civil Engg. and Management, pp.107-114.
- [3] Baskar. K, Shanmugam N.E. (2003), " Steel Concrete Composite Plate Girder Subjected to Combined Shear and Bending," J. Constr. Steel Res., 59, pp.531-557.
- [4] Brian Uy and Mark Bradford (1995), "Ductility of Profiled Composite Beams Part.1 Experimental Study, Journal of Structural Engg, Vol.121,No.5, May 1995, pp. 876-882.
- [5] Chapman, J.C., Balakrishnan, S. (1964), "Experiments on Composite Beams," Struct. Eng., 42(11), 369-383.
- [6] Chapman.J.C.,Yam.L.C.P. (1968), "The inelastic behaviour of simply supported composite beams of steel and concrete" Proc.Inst.Civ.41 (651-683).
- [7] Carmel Navin, "studies on composite beam subjected to combined bending and torsion"Proc. of SEC-2008.
- [8] Derrick John Oehlers (1993), "Composite Profiled Beams," Journal of Structural Engg., Vol.119, No.4, April 1993, pp.1085-1100.
- [9] George Abdul Sayed (1982), "Composite Cold Formed Steel Concrete Beams," Journal of Structural Division, Vol.108, No.11, pp. 2609-2622.
- [10] Ghosh, B. and Mallik, S.K. (1979) "Strength of Steel Concrete Composite Beams under Combined Flexure and Torsion," The Indian Concrete Journal, 53, 48-53.
- [11] Hyung, J. Hyun Ryu, (2007), "Experimental Study on Flexural Strength of Modular Composite Profile Beams," J. Steel and Composite Structures, Vol-7, no.1, pp.71-85.
- [12] JianguoNie, Cai C.S. (2004), "Stiffness and Deflection of Steel Concrete Composite Beams under Negative Bending," Journal of Structural Engineering, Vol. 130, No. 11, November 2004, pp.1842-1851.
- [13] JianguoNie ,Cai., C.S (2009), "Performance of Steel-Concrete Composite Beams under Combined Bending and Torsion ," Journal of Structural Engineering, Vol. 135, No. 9, September 2009, pp.1048-1057.22. Johnson, R.P. (1975), "Composite Structures of Steel and Concrete," Volume-I-Blackwell Scientific Publication, London.
- [14] Khandeker m. Anwar Hossain (2003), "Experimental and Theoretical Behavior of Thin Walled Composite Filled Beams," eJSE, pp. 117-139.

## International Journal of Innovative Research in Science, Engineering and Technology

*(An ISO 3297: 2007 Certified Organization)*

**Vol. 5, Issue 3, March 2016**

- [15] Kottiswaran. N., Sundararajan. R., (2005), “ Behavior Thin Walled Cold Formed Steel Concrete Composite Beams,” Proc. of National Seminar REDECON 2005, pp 373-381.
- [16] Max, L. Porter. (1976), “Design Recommendation for Steel Deck Floor Slabs,” Journal of Structural Division, ASCE, Vol -102, No. 11, pp. 2121-2136.
- [17] Ray, M.B. and Mallik, S.K. (1980), “Interaction of Flexure and Torsion in Steel Concrete Composite Beams,” The Indian Concrete Journal, 54, 80-83.
- [18] Richard, P. Nguyen (1991), “Thin Walled Cold Formed Steel Composite Beams,” Journal of Structure Engg, Vol.117, No.10, October 1991, pp. 2936-2952.
- [19] Singh, R.K. and Mallik, S.K. (1977), “Experiments on Steel Concrete Composite beams subjected to Torsion and Combined Flexure and Torsion,” The Indian Concrete Journal , 51, 24-30.
- [20] IS 456 -2000, “Code of Practice for Plain and Reinforced Concrete,” Bureau of Indian Standards, New Delhi.
- [21] IS 11384-1985, “Composite Construction in Structural Steel and Concrete,” Bureau of Indian standards, New Delhi.
- [22] IS: 801 (2007), “Code of Practice for the Use in Cold Formed Light Gauge Steel Structural members in General Building Construction”, Bureau of Indian Standards, New Delhi.
- [23] IS 3935-1996, “Code of Practice for Composite Construction”, Bureau of Indian standards, New Delhi.
- [24] BS 5950-3.1: 1990, “Code of Practice for Design of Simple and Continuous Composite Beams”.