

# Fluid Structure Interaction of Liquid Lubricated Cylindrical Journal Bearing using CFD

K B S V D Prasad<sup>1</sup>, Dr.K.Balaji Reddy<sup>2</sup>, R Sam Sukumar<sup>3</sup>, Amruthaluri Sai Teja<sup>4</sup>, Vanamali Rambabu<sup>5</sup>,  
Gubbala Rajesh<sup>6</sup>, Ravi Wesley Moses<sup>7</sup>, Pilli Ashok Kumar<sup>8</sup>

Assistant Professor, Department of Mechanical Engineering, Swarnandhra Engineering College, Narasapuram, W.G  
Dist., A.P, India<sup>1</sup>

Principal & Professor in Department of Mechanical Engineering, Swarnandhra Engineering College, Narasapuram,  
W.G Dist., A.P, India<sup>2</sup>

Associate Professor, Department of Mechanical Engineering, Swarnandhra College of Engineering and Technology,  
Narasapuram, W.G Dist., A.P, India<sup>3</sup>

UG Students, Department of Mechanical Engineering, Swarnandhra Engineering College, Narasapuram,  
W.G Dist., A.P, India<sup>4-8</sup>

**ABSTRACT:** Computational methods were used to analyse the elastic-hydrodynamic lubrication of a complex rotor-bearing system. The methodology employed computational fluid dynamics (CFD), based on the Navier–Stokes equation and a fluid–structure interaction (FSI) technique. A series of models representing the system were built using the CFD–FSI methodology to investigate the interaction between the lubrication of the fluid film, and elastic dynamics of the rotor and journal bearing. Journal bearings have the longest history of scientific study of any class of fluid film bearings. In a fluid film bearing, the pressure in the oil film satisfies the Reynolds equation which is a function of film thickness. Hydrodynamic journal bearings are analysed by using Computational fluid dynamics (CFD) and fluid structure interaction (FSI) approach in order to find deformation of the bearing. The present work focuses on journal bearings for L/D ratio and different eccentricity ratios are modelled in 3D modelling software CATIA. The L/D ratio considered is 0.5 and eccentricity ratios considered are 0.2, 0.4, 0.6 and 0.8 and lubricants considered are SAE 20 & SAE 40 oils. Journal bearing models are developed for speed of 2000 rpm to study the interaction between the fluid and elastic behaviour of the bearing. The speed is the input for CFD analysis and the pressure obtained from the CFD analysis is taken as input for structural analysis. Computational fluid dynamics (CFD) and fluid structure interaction (FSI) is done in ANSYS.

**KEYWORDS:** L/D ratio, Eccentricity ratios, CFD Analysis, Fluid Structure Interaction (FSI) technique.

## I. INTRODUCTION

A plain bearing (sometimes called a solid bearing) is the simplest type of bearing, comprising just a surface and no rolling elements. Therefore the journal (i.e., the part of the shaft in contact with the bearing) slides over the bearing surface. The Simplest example of a plain bearing is a shaft rotating in a hole. A simple linear bearing can be a pair of flat surfaces designed to allow motion; e.g., a drawer and the slides it rests on or the ways on the bed of a lathe. Plain bearings, in general, are the least expensive type of bearing. They are also compact and lightweight, and they have a high load-carrying capacity[1-5].

# International Journal of Innovative Research in Science, Engineering and Technology

(An ISO 3297: 2007 Certified Organization)

Vol. 5, Issue 3, March 2016

**1.1 DESIGN:** The design of a plain bearing depends on the type of motion the bearing must provide

**1.2 JOURNAL (FRICTION, RADIAL OR ROTARY) BEARING:** This is the most common type of plain bearing; it is simply a shaft rotating in a bearing. In locomotive and railroad car applications a journal bearing specifically referred to the plain bearing once used at the ends of the axles of railroad wheel sets, enclosed by journal boxes (axle boxes). Axle box bearings today are no longer plain bearings but rather are rolling-element bearings.

**1.3 MATERIALS:** Plain bearings must be made from a material that is durable, low friction, low wear to the bearing and shaft, resistant to elevated temperatures, and corrosion resistant. Often the bearing is made up of at least two constituents, where one is soft and the other is hard. The hard constituent supports the load while the soft constituent supports the hard constituent. In general, the harder the surfaces in contact the lower the coefficient of friction and the greater the pressure required for the two to seize[6-8].

**1.4 BABBITT:** Babbitt is usually used in integral bearings. It is coated over the bore, usually to a thickness of 1 to 100 thou (0.025 to 2.540 mm), depending on the diameter. Babbitt bearings are designed to not damage the journal during direct contact and to collect any contaminants in the lubrication.

## II. PROBLEM STATEMENT

### 2.1 PROBLEM SOLVING METHODOLOGY

In this work journal bearings for L/D ratio and different eccentricity ratios are modelled in 3D modelling software CATIA. The L/D ratio considered is 0.5 and eccentricity ratios considered are 0.2, 0.4, 0.6 and 0.8.

Journal bearing models are developed for speed of 2000 rpm to study the interaction between the fluid and elastic behaviour of the bearing. The speed is the input for CFD analysis and the pressure obtained from the CFD analysis is taken as input for structural analysis.

### 2.2 JOURNAL BEARING MODEL CALCULATIONS

L=Length of journal=50 mm  
D=diameter of journal=100mm  
L/D ratio=0.5

### 2.3 ECCENTRICITY CALCULATIONS

$\epsilon$  =eccentricity ratio  
C= radial clearance=0.145mm  
e = eccentricity (mm)

**Table 1 Eccentricity Calculation at different eccentricity ratio**

Cases	$\epsilon$	C	$e = \epsilon \times C$
1	0.2	0.145	0.029
2	0.4	0.145	0.058
3	0.6	0.145	0.087
4	0.8	0.145	0.116

# International Journal of Innovative Research in Science, Engineering and Technology

(An ISO 3297: 2007 Certified Organization)

Vol. 5, Issue 3, March 2016

**Table 2 Models and 2D Drawings of Journal Bearing In CATIA**

L/D ratio	Eccentricity ratio			
0.5	0.2	0.4	0.6	0.8

## 2.4 THEORETICAL CALCULATIONS OF JOURNAL BEARING WITH L/D RATIO

### STRESS CALCULATIONS

F=force N

D=diameter of the journal bearing=100mm

μ =coefficient of friction

L=length of the journal bearing=50mm

N=speed=2000rpm

C=clearance=0.25mm

$$F = \frac{\pi^2 \times D^2 \times L \times N}{30 \times C} \times \mu$$

$$\sigma = \frac{F \cdot N}{A} / mm^2$$

**Table 3: Stress Calculation table**

Cases	L/D	F(N)	σ(N/mm <sup>2</sup> )
1	0.5	1314613.33	41.84

[Note: Calculate stress at L/D and ε.]

## 2.5 PRESSURE CALCULATIONS

F=shaft carrying load=8000N (taken from journal)

r =radius of journal bearing

l =length of the journal bearing

$$P = \frac{F}{2\pi r l}$$

**Table 4: Pressure Calculation table**

Cases	L/D	L	F	R	P(Pa)
1	0.5	50	8000	50	509554.1401

## III. MODELLING

### 3.1 INTRODUCTION TO CAD:

Computer-Aided Design (CAD), also known as Computer-Aided Design and Drafting (CADD), is the use of computer technology for the process of design and design-documentation. Computer Aided Drafting describes the process of drafting with a computer. CADD software, or environments, provides the user with input-tools for the purpose of streamlining design processes, drafting, documentation, and manufacturing processes. CADD output is often in the form of electronic files for print or machining operations. The development of CADD-based software is in direct correlation with the processes it seeks to economize; industry-based software (construction, manufacturing, etc.) typically uses vector-based (linear) environments whereas graphic-based software utilizes raster-based (pixelated) environments [9-10].

# International Journal of Innovative Research in Science, Engineering and Technology

(An ISO 3297: 2007 Certified Organization)

Vol. 5, Issue 3, March 2016

## 3.2 INTRODUCTION TO CATIA:

CATIA is a one of the world's leading high-end CAD/CAM/CAE software packages. CATIA (Computer Aided Three dimensional Interactive Application) is a multi-platform PLM/CAD/CAM/CAE commercial software suite developed by Dassault Systems and marketed world-wide by IBM. CATIA is written in the C++ programming language. CATIA provides open development architecture through the use of interfaces, which can be used to customize or develop applications. The application programming interfaces supported Visual Basic and C++ programming languages. Commonly referred to as 3D Product Lifecycle Management (PLM) software suite, CATIA supports multiple stages of product development. The stages range from conceptualization, through design (CAD) and manufacturing (CAM), until analysis (CAE). Each workbench of CATIA V5 refers an each stage of product development for different products. CATIA V5 features a parametric solid/surface-based package which uses NURBS as the core surface representation and has several workbenches that provide KBE (Knowledge Based Engineering) support.

**FEATURE-BASED MODELING:** In CATIA V5, solid models are created by integrating a number of building blocks called features.

**PARAMETRIC MODELING:** The parametric nature of a software package is defined as its ability to use the standard properties or parameters in defining the shape and size of a geometry.

**ASSOCIATIVELY:** Associatively ensures that if any modification is made in the model in any one of the workbenches of CATIA V5, it is automatically reflected in the other workbenches immediately.

**B-REP MODELING:** Most of the components Designed using CATIA V5 are based on B-Rep modeling technique i.e. models are created by extruding the boundary of the model in a specified direction.

**DIFFERENT MODULES IN CATIA:** Sketcher, Part Design, Assembly Design, Drafting, Sheet metal

## IV. DESIGN

### 4.1 DESIGN THE JOURNAL WITH L/D RATIO AND DIFFERENT ECCENTRICITY RATIOS:

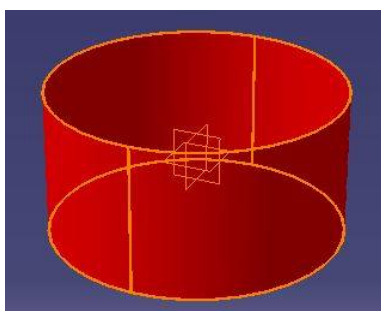

Fig 4.1 (a): Fluid

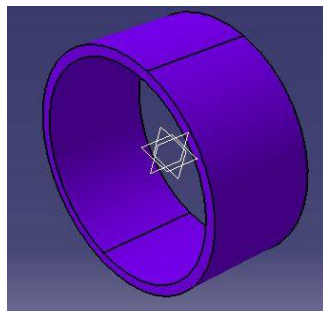

Fig 4.1 (b): Solid

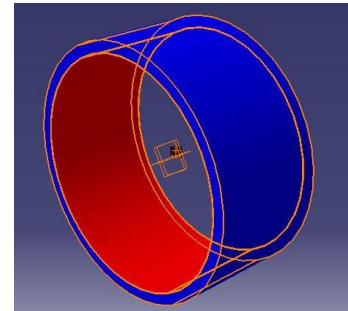

Fig 4.1 (c): Assembly

Fig 4.1(a), (b), (c) shows L/D ratios 0.5 and different eccentricity ratios (0.2, 0.4, 0.6 and 0.8) to draw the fluid object in 2D viewport then we converted into 3D dimensional viewport. Similarly to draw solid object into 2D viewport then we converted into 3D view ports and both layers are assembled. In this upper layer is solid and lower layer is fluid. The same process is repeated for different eccentricity ratios.

# International Journal of Innovative Research in Science, Engineering and Technology

(An ISO 3297: 2007 Certified Organization)

Vol. 5, Issue 3, March 2016

## V. CFD ANALYSIS

CFD, usually abbreviated as Computational fluid dynamics, is a branch of fluid mechanics that uses numerical methods and algorithms to solve and analyse problems that involve fluid flows. Computers are used to perform the calculations required to simulate the interaction of liquids and gases with surfaces defined by boundary conditions. With high-speed supercomputers, better solutions can be achieved. Ongoing research yields software that improves the accuracy and speed of complex simulation scenarios such as transonic or turbulent flows [11-16].

Initial experimental validation of such software is performed using a wind tunnel with the final validation coming in full-scale testing, e.g. flight tests.

### 5.1 METHODOLOGY FOR CFD

- In all of these approaches the same basic procedure is followed.
  - During pre-processing,
  - The geometry (physical bounds) of the problem is defined.
- The volume occupied by the fluid is divided into discrete cells (the mesh). The mesh may be uniform or non-uniform.
- The physical modelling is defined, for example, the equation of motion+ enthalpy+ radiation+ species conservation.
- Boundary conditions are defined. This involves specifying the fluid behaviour and properties at the boundaries of the problem. For transient problems, the initial conditions are also defined.
- The simulation is started and the equations are solved interactively as a study state or transient.
- Finally a post-processor is used for the analysis and visualization of the resulting solution

### 5.2 MATERIAL PROPERTIES

Table 5: Properties of fluid and solid materials

PROPERTIES	FLUID		SOLID
	SAE20	SAE40	BABBIT MATERIAL
Density (kg/m <sup>3</sup> )	872	887	0.000007272
Thermal conductivity (w/m-k)	0.136	0.136	Young's modulus = 50,000MPa
Specific heat C <sub>p</sub> (J/kg-k)	19252.96	1800	
Viscosity (kg/m-s)	0.0056	0.0143	Poisson's ratio=0.35
Velocity of flow (m/s)	10.45	10.45	

Open Ansys Workbench 14.5, It opens a project Schematic window with tool box graphical User Interface with some other important tools. Use import tool to import the geometry with IGES or STEP file format. After importing the geometry file, we do the Analysis. Now on our Analysis of Journal Bearing - FSI (Fluid Structure Interaction) done. Imported Model in the ANSYS work bench looks as shown below.

#### Case 1: When L/d ratio 0.5 & Eccentricity ratio 0.2:

Ansys → workbench → select analysis system → fluid flow fluent → double click → Select geometry....

**5.3 COMPUTATIONAL FLUID DYNAMICS ANALYSIS**

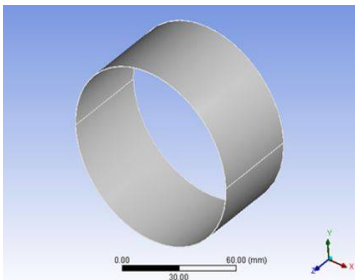

**Fig 5.1 Geometry model**

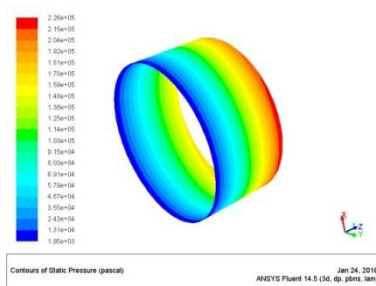

**Fig 5.2 Pressure Contours**

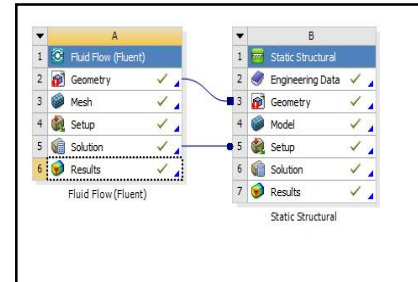

**Fig 5.3 Import CFD to Structural**

In CFD analysis process (Fig 5.1,5.2,5.3), to import fluid geometry we converted into finite element i.e., meshed model. To indicate inlet and outlet conditions for further process and finally pressure contour results. After completion we import CFD results into structural analysis as an input.

**5.4 STRUCTURAL ANALYSIS**

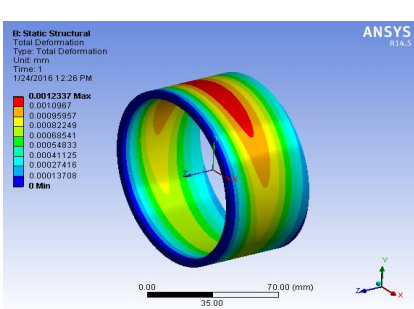

**Fig 5.4 TOTAL DEFORMATION**

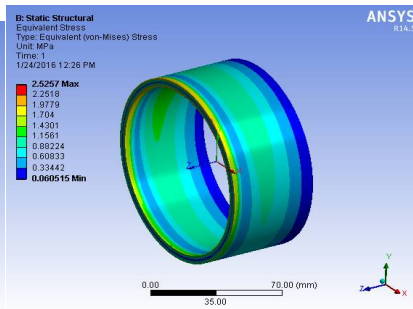

**Fig 5.5 EQUIVALENT STRESS**

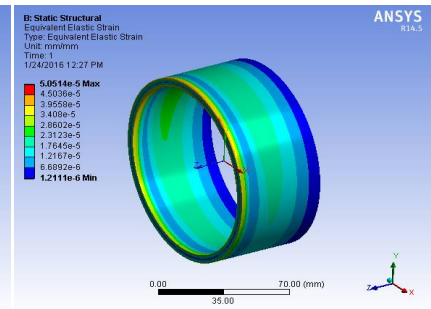

**Fig 5.6 EQUIVALENT STRAIN**

In fig 5.4 shows structural analysis the eccentricity ratios 0.2 and lubricant SAE 20 oil total deformation changes. In fig 5.5 shows structural analysis the eccentricity ratios 0.2 and lubricant SAE 20 oil equivalent stress changes. In fig 5.6 shows structural analysis the eccentricity ratios 0.2 and lubricant SAE 20 oil equivalent strain changes.

**VI. RESULTS AND DISCUSSIONS**

**6.1 FOR SAE-20-OIL**

The following table 6 shows the Pressure, Total Deformation, Stress and Strain values for various eccentricity ratios with SAE20 oil.

**Table 6: Results of SAE 20 oil with respect to eccentricity ratios at L/D ratio 0.5**

Eccentricity ratios	Pressure MPa	Total deformation in mm	Stress MPa	Strain
0.2	0.22225	0.0012337	2.5257	5.0514e-5
0.4	0.27502	0.0016267	2.9943	5.98922e-5
0.6	0.34984	0.0021927	3.8717	7.7442e-5
0.8	0.4595	0.002988	5.0492	0.000101

# International Journal of Innovative Research in Science, Engineering and Technology

(An ISO 3297: 2007 Certified Organization)

Vol. 5, Issue 3, March 2016

## 6.2 FOR SAE-40-OIL

The following table 7 shows the Pressure, Total Deformation, Stress and Strain values for various eccentricity ratios with SAE40 oil.

**Table 7: Results of SAE 40 oil with respect to eccentricity ratios at L/D ratio 0.5**

Eccentricity ratios	Pressure MPa	Total deformation in mm	Stress MPa	Strain
0.2	0.5648	0.0031421	6.4321	0.00019426
0.4	0.66617	0.0043143	7.6096	0.0001286
0.6	0.87597	0.0054917	9.7121	0.00019426
0.8	1.1379	0.0073887	12.49	0.00024984

## 6.3 COMPARISON OF RESULTS FOR DIFFERENT ECCENTRICITY RATIOS

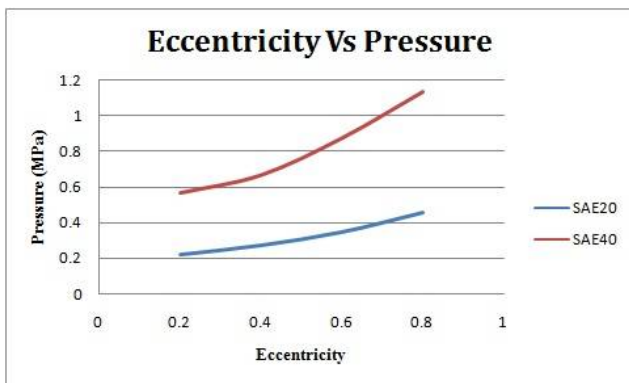

**Fig 6.1** Variation of maximum pressure for various eccentricity ratios

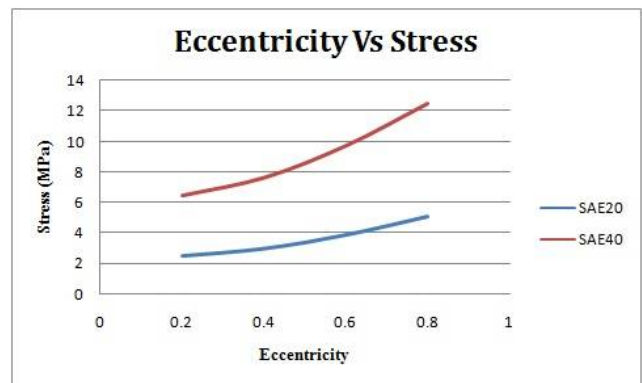

**Fig 6.2** Variation of maximum stress for various eccentricity ratios

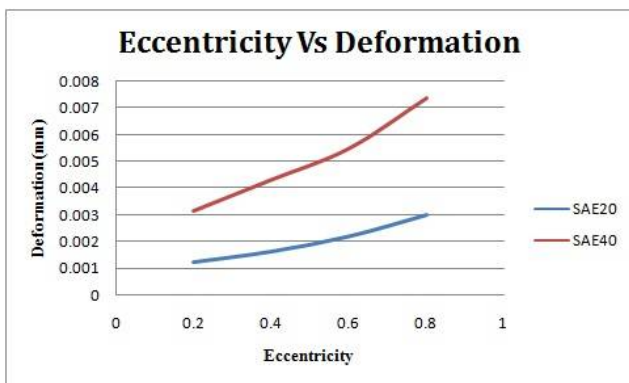

**Fig 6.3** Variation of maximum deformation for various eccentricity ratios

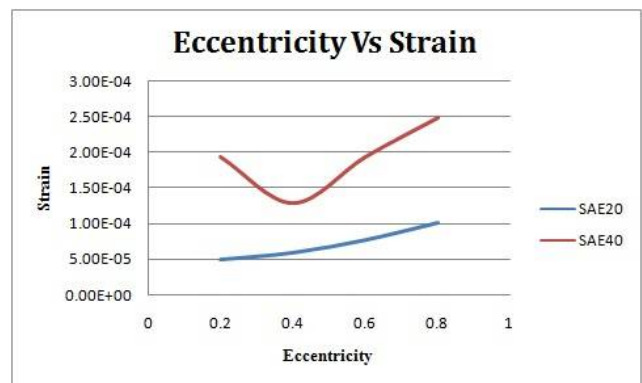

**Fig 6.4** Variation of maximum strain for various eccentricity ratios

In Fig 6.1 shows variation of maximum pressure for various eccentricity ratios and lubricants. In Fig 6.2 shows variation of equivalent stress for various eccentricity ratios and lubricants. In Fig 6.3 shows variation of total deformation for various eccentricity ratios and lubricants. In Fig 6.4 shows variation of equivalent strain for various eccentricity ratios and lubricants. All graphs shows that deformation, stress, strain and pressure varies linearly with eccentricity ratios for both SAE20 and SAE40.

# International Journal of Innovative Research in Science, Engineering and Technology

(An ISO 3297: 2007 Certified Organization)

Vol. 5, Issue 3, March 2016

## VII. CONCLUSION

In this paper, Hydrodynamic journal bearings are analysed by using Computational fluid dynamics (CFD) and fluid structure interaction (FSI) approach on different models by varying eccentricity ratios using Ansys in order to evaluate the fluid pressures, Stress distribution deformation and strain in journal bearing. Journal bearings for different eccentricity ratios and L/D ratio are modelled in 3D modelling software CATIA. The L/D ratio considered is 0.5 and eccentricity ratios considered are 0.2, 0.4, 0.6 and 0.8.

By observing the CFD analysis results, the pressure is increasing by increasing the eccentricity ratio thereby increasing the displacements stress and strain values. In strain values for SAE 40 oil decreases suddenly and increases gradually when comparing to SAE 20 oil.

From the Analysis, deformation, stresses and strain of the bearing due to action of hydrodynamic forces developed for accurate performance of the bearings operation under severe conditions can be evaluated. It is observed that there is substantial amount of deformation of the bearing. By comparing these results SAE 20 oil and Eccentricity ratio 0.2 is best suited for journal bearing.

## VIII. FEATURE SCOPE OF THE PROJECT

In this work, the lubricants used are liquid lubricants. For further assessment, gas lubricants can be analysed. Different L/D ratios and eccentricity ratios can also be considered for further work and for higher speeds.

## REFERENCES

- [1] MahenderJanagam, D. Prasuna Lilly Florence and Dr. P. H V SessaTalpaSai, Fluid Structure Interaction On Journal Bearings At Different L/D And Eccentricity Ratios, International Journal of Science, Engineering and Technology Research (IJSETR), Volume 4, Issue 11, November 2015.
- [2] B. S. Shenoy, R. S. Pai, D. S. Rao and R. Pai, Elasto-hydrodynamic lubrication analysis of full 360° journal bearing using CFD and FSI techniques, ISSN1746-7233, England,UK World Journal of Modelling and Simulation Vol. 5 (2009) No. 4, pp. 315-320.
- [3] B. S. Shenoy, R. S. Pai, D. S. Rao, R. Pai, Elasto-hydrodynamic lubrication analysis of full 360° journal bearing using CFD and FSI techniques, World Journal of Modeling and Simulation, ISSN 1 746-7233, Vol. 5 (2009) No. 4, pp. 315-320.
- [4] PriyankaTiwari, Veerendra Kumar, Analysis of Hydrodynamic Journal Bearing Using CFD and FSI Technique, www.ijert.org, Volume/Issue: Vol. 3 - Issue 7 (July - 2014), e-ISSN: 2278-0181.
- [5] Samuel A. McKee, Journal-Bearing Design As Related To Maximum Loads, Speeds, And Operating Temperatures, Part of Journal of Research of the National Bureau of Standards, Volume 19, October 1937.
- [6] S. Sharma, D. Hargreaves, W. Scott, Journal bearing performance and metrology issues, Journal of Achievements in Materials and Manufacturing Engineering
- [7] P.C. Mishra, Analysis of a Rough Elliptic Bore Journal Bearing using Expectancy Model of Roughness Characterization.
- [8] P. Allaire, J. Nicholas, E. Gunter. Systems of Finite Elements for finite bearings. ASME Journal of Lubrication, Technology, 1972, (99): 187–197.
- [9] P. Allaire, J. Nicholas, E. Gunter. Systems of Finite Elements for finite bearings. ASME Journal of Lubrication Technology, 1972, (99): 187–197.
- [10] P.Bhat,B.Shenoy,R.Pai. Elasto-hydrodynamicLubricationAnalysisofaRadiallyAdjustablePartialArcBearing Using Fluid Structure Interaction. in: Proc. of ASME/STLE International Joint Tribology Conference, San Diego, California, US, 2007, 1–3. IJTC'07, IJTC44479.
- [11] J. Booker, K. Huebner. Application of Finite Element Methods to Lubrication: an Engineering Approach. ASME Journal of Lubrication Technology, 1972, (94): 313–323.
- [12] P. Brajdic-Mitidieri, A. Gosman, et al. CFD Analysis of a Low Friction Pocketed Pad Bearing. ASME Journal of Tribology, 2005,127(4): 803–812.
- [13] P. Chen, E. Hahn. Use of Computational Fluid Dynamics in Hydrodynamic Lubrication. Proceedings of Institute of Mechanical Engineers: Part J, Journal of Engineering Tribology, 1998, (6): 427–435.
- [14] B. George, W. Fred. Analytical Derivation and Experimental Evaluation of Short Bearing Approximation for Full Journal Bearings. NACA TN, 1953, 1199–1230.
- [15] Z. Guo, H. Toshio, R. Gordon. Application of CFD Analysis for Rotating Machinery Part1: Hydrodynamic, Hydrostatic Bearings and Squeeze Film Damper. Journal of Engineering for Gas Turbines and Power, 2005, 127(2): 445–451.
- [16] M. Reddi. Finite-Element Solution of the Incompressible Lubrication Problem. ASME Journal of Lubrication Technology, 1969,91(3): 524–533