

A Study on Variable Frequency Drive and It's Applications

Yogita Y. Garud¹, Sayali R. Gole², Rutuja T. Jadhav³, Seema U. Deoghare⁴

U.G. Student, Department of E&Tc Engineering, PCCOE, Pune, India^{1,2,3}

Assistant Professor, Department of E&Tc Engineering, PCCOE, Pune, India⁴

ABSTRACT: A variable frequency drive (VFD) is a type of adjustable speed drive used in electro-mechanical drive systems to control AC motor speed and torque by varying motor input frequency and voltage. VFD helps to limit demand and electrical consumption of motors by reducing the amount of energy they consume. The features of VFD are smooth start of motor and energy conservation in different industrial applications. This paper is intended to provide a basic understanding of VFD operation and VFD benefits. In addition this paper will discuss some basic application of VFD in industry.

KEYWORDS: Variable frequency drive, Cement industry, Air conditioner, Irrigation system

I. INTRODUCTION

VFD is variable frequency drive. VFD can also refer as variable speed drive, adjustable speed drive, adjustable frequency drive, AC drive, micro drive and inverter. It is a system which gets used to control the speed of electric motor by controlling the frequency and voltage. Frequency is directly proportional to the speed of electric motor. By adjusting the frequency, speed can be varied according to requirements or applications. VFD makes the process reliable and output variable is easily controlled. Variable frequency drive have different types as Voltage source inversion (VSI), Current source inversion (CSI), Pulse width modulation (PWM). Mainly PWM based VFD used in industries as CSI required large inductor while constructing and VSI have poor power factor. VFD increases the life span of motor.

VFD gets used in many applications to save power. In this paper different applications where VFD can be used are explained. One of the applications of VFD is cement industry. In process of cement making at every stage VFD get used. In this paper need of VFD in cement industry is discussed. Variable speed drives are very important in conveyors to control torque and speed.

Our many home appliances also use VFD. In air conditioner system VFD is used to conserve energy. How energy get saved using VFD is explained in paper. VFD can be used in irrigation system. It is possible to control the flow of water according to the requirement using VFD. Pumping with multi flow is possible with VFD. There are many applications where VFD is suitable. As it saves lots of amount of energy; it is also used in many industries.

II. RELATED WORK

I] WORKING PRINCIPLE OF VARIABLE FREQUENCY DRIVE:

A variable frequency drive converts incoming 50 Hz power into DC, then converts to a variable voltage, variable frequency output. In [1] block diagram of variable frequency drive figure is mentioned.

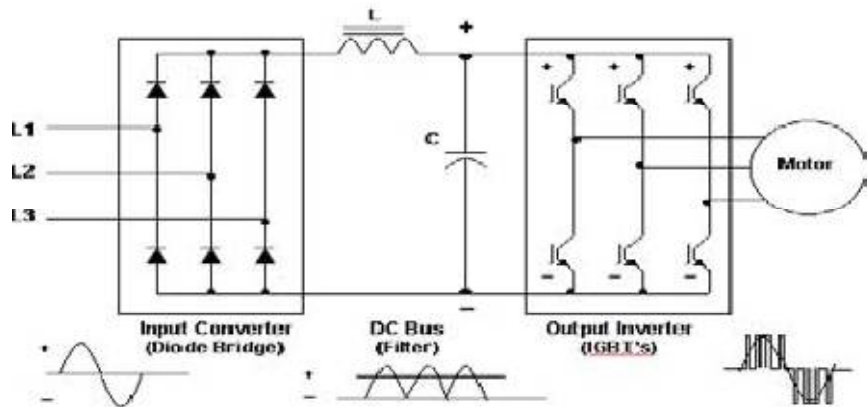

Fig.1 Block diagram of Variable Frequency Drive

Fig.1 shows the block diagram of variable frequency drive. Figure shows that VFD has three stages as input converter, DC bus, and Output inverter. Input converter is consisting of Diode Bridge. DC bus consists of inductor and capacitor. Output converter is consist IGBT. Output inverter is connected to motor.

The working of three stages of VFD is as follows:

Converter:

The first stage of motor controller or VFD is converter. Converter is made up of six diodes. Three phase voltage is directly supplied to the converter. Converter allows the current to flow only in one direction. If one of the phase voltages from L1, L2, L3 is greater than another two phase voltages then diode connected to that phase voltage get turn on and same principal get used at negative side of diode. At the output six current pulses occurs, so it is also called as 6 pulse VFD. 6 pulse VFD get used in building electrical system such as electronics ballast, uninterrupted power supply etc. VFD can be configured as 12 pulses VFD and 18 pulse VFD. As 6 pulse VFD has more harmonic distortion to avoid this drawback mostly 12 pulse VFD or 18 pulse VFD is used. The converter unit converts 3 phase incoming AC supply into DC. The commonly used configuration of converter is 3 phase full wave Diode Bridge.

DC bus:

The second stage of VFD is DC bus. The basic principal of DC bus is to remove ripples. The DC bus is the link between converter and inverter. At the output of rectifier circuit we get dc signal. The output of rectifiers contains large number of ripples so dc bus removes ripples from output. It also provides protection for the drive. At the output of DC bus ripple free Dc is present.

Inverter:

The last stage of VFD is inverter. Inverter is made up of transistors. Transistors work as switches. In industry IGBT that is insulated gate bipolar transistor get most commonly used. If one of switch from top get closed then phase of electric motor get connected to positive DC bus and voltage on that phase becomes positive. Same principal get used for the switches at bottom and for these bottom switches phase get negative DC bus and voltage on that phase become negative. By turning on switches in any order, the phase and the rotation of electric motor can be changed. So making phase voltage positive, negative or zero, variable frequency gets at the output. As frequency is directly proportional to the speed of motor and motor speed get varied according to requirement or applications. So Inverter is a unit where filtered DC supply is being converted to AC Supply which is supply to the electric motor connected to it.

SPEED CONTROL METHODS:

The methods used to control speed of electric motors are as follows:

- 1) V/F control

International Journal of Innovative Research in Science, Engineering and Technology

(An ISO 3297: 2007 Certified Organization)

Vol. 5, Issue 3, March 2016

In electric motor, voltage induced in the stator of electric motor is directly proportional to the frequency and air gap flux. If we reduce the frequency keeping voltage constant then there is increase in air gap flux. This is undesirable effect. So to vary speed we must keep V/F ratio constant. V/F method uses the technique in which several motors can be connected to the single VFD. V/F control techniques has advantages like low starting current and have wide range of speed. V/F control method does not used where precise speed regulation operator is required.

2) V/F with encoder

To have precise speed regulation V/F with encoder get used. Encoder provides high reference frequency. Thus speed regulation depends on the feedback provided by the encoder. But this method is costly so not get used in many applications.

3) Open loop V/F control

To have dynamic speed response open loop V/F control gets used in industries. In this method stator voltage and frequency both varied simultaneously. Air gap flux remains constant. As frequency and voltage varies at a time, V/f ratio remains constant.

4) Closed loop V/F control

In closed loop V/F control, feedback system gets used. The measured speed of electric motor and reference speed get compared. According to difference between both these speed , frequency and voltage get varied to remain V/F ratio constant. To measure the speed of electric motor sensor get used and to change the frequency controller get used. Mainly Proportional controller gets used.

All above control method uses the Pulse Width Modulation technique to change the speed by varying the width of fixed signal. By varying the width of fixed signal, frequency gets varied. PWM provides the firing angle to the transistors or switches used in inverter block. PWM generates firing angle by comparing the triangular wave with the reference signal. In industries mainly PWM based generator used as initial transients are less.

III. APPLICATIONS OF VARIABLE FREQUENCY DRIVE:

1] Variable frequency drive in cement industry

Primary elements of cement are limestone and clay. These materials are crushed into fine powder and then blended. In process of cement making at every stage VFD get used. VFD gets used to control the speed of fans, mills, conveyors etc. The control process through variable frequency drives leads to efficient speed control, low power losses, energy savings, low pollution and significant saving in economy.

Following figure shows the process of cement making:

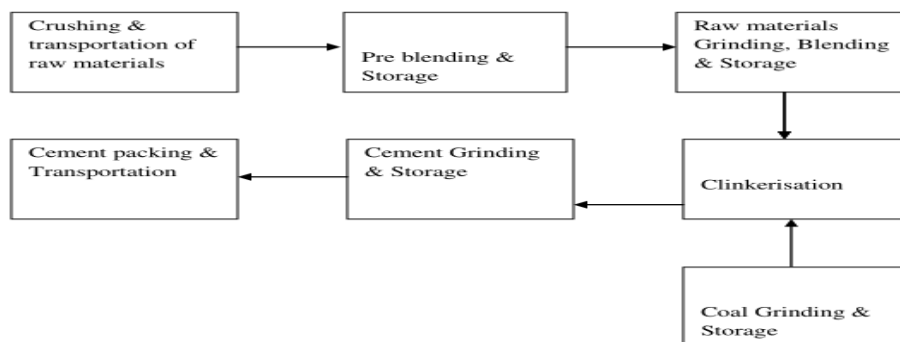

Fig.2 Block diagram of Cement making Process

International Journal of Innovative Research in Science, Engineering and Technology

(An ISO 3297: 2007 Certified Organization)

Vol. 5, Issue 3, March 2016

Fig.2 shows the block diagram of cement making process. Cement is made up of raw materials like clay, limestone. Cement making process have different steps involved as shown in figure. These steps are crushing, pre blending and grinding of raw materials. Clinkerisation is the process where cooling is done to avoid further chemical reactions. After clinkerisation, final grinding of cement is done. Last step of cement making process is transportation of cement.

The overall process of cement industry is divided into parts . Two parts as mentioned below:

1. Induced Draft Fan for Cement Kiln
2. Conveyors

1. Induced Draft Fan for Cement Kiln

It is required to control the process requirements throughout the operation. Previously dampers, vanes, variable slip clutches get used to control the speed. But they have disadvantages like high power consumption and maintenance is required. To overcome this drawback VFD get used. In [2] advantages of cement industry are mentioned.

- i} Maintenance of uniform working temperature, reduced fan noise and saving of valuable floor space in the plant.
- ii} The ID fan power can be several thousand hp and using a drive to control air flow can result in considerable energy savings
- ii} VFD optimizes the fan RPM in such a manner that it precisely matches the system operating conditions.

2. Conveyors

Conveyor is used to handle raw material and finished material. Conveyor gets used continuously in the cement making process therefore chances of braking conveyor get increased. It increases operational cost. To reduce operational costs, it is important to extend the belt lifetime and availability. Variable speed drives provide accurate torque and speed control of conveyors. This reduces the stress on mechanical equipment such as gearboxes, pulley and belts, especially during start-up and stopping, but also during operation and maintenance .With the use of VFD it is possible to control the speed of the conveyors to match the production capacity and as such reduce wear and save energy. For maintenance inspection, belt changes or repairs or avoidance of ice build-up it is possible to run the conveyor belt at slow speed [2].

2] Variable frequency drive in air conditioner

As the rapid development of economy and the improvement of people's standard of living, the central air-conditioning system has become popular in the hotels, office buildings, supermarkets, hospitals, factories, etc. The consumption of electricity by air conditioner is increasing day by day. If we adopt reasonable and intelligent technology, plus the best modern design using VFD, we can conserve energy. The air-conditioning system mainly consists of refrigeration compressor group, cooling (heat) medium circulating water system, cooling circulating water system, cooling tower fan and coil pipe fan. However, air-conditioning systems currently have a drawback that is it is hard to control their output temperature according to seasons.

From the theory of fluid mechanics, the output flow quantity of the centrifugal pump or fan is directly proportional to its speed, the output pressure is directly proportional to the square of the speed while the output power is directly proportional to the cube of the speed. From this, it is easy to draw a conclusion that we can adjust the output power of the pump and fan through controlling their speed.

Air conditioning system has Cooling water system Closed-loop control block. The standard required circulating water temperature for system is 12°C intake and 7°C outlet, with allowable temperature difference of 5°C. If the temperature difference between the intake and outlet is 3°C, it shows that the actual demand of the supply is $3^{\circ}\text{C}/5^{\circ}\text{C}=60\%$. By using VFD we can control speed of the pump to 60% of its rated speed which ultimately saves the energy.

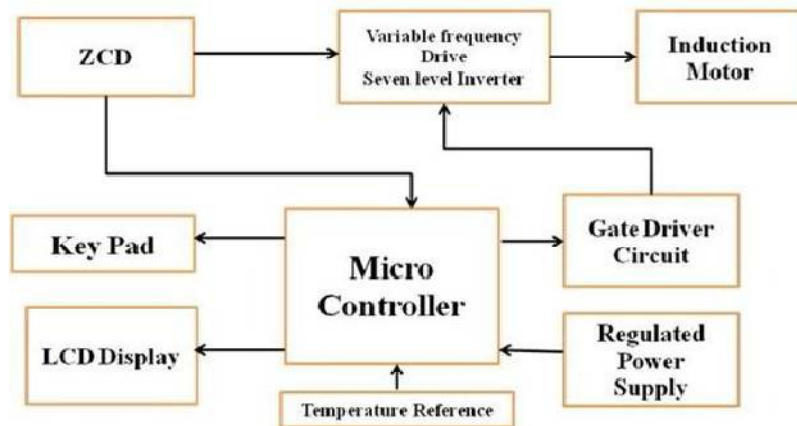

Fig.3 Block diagram of air conditioner system using VFD

Fig.3 shows the block diagram of air conditioner system using VFD. Block diagram consists of ZCD, VFD, LCD display, Microcontroller, Power supply, Temperature reference, Gate driver circuit, Induction motor and keypad.

There is way to save energy in air condition system using VFD (seven level inverters). Block diagram of that system is mentioned in [3]. It consists of 230V ac supply which is given to the rectifier circuit. The rectifier circuit converts ac into dc. This regulated dc voltage is given to the seven level inverter which produces pure sine wave and it is given to the induction motor. The microcontroller is used to produce the PWM sequences with references to the temperature given. In turn the PWM sequences only control the output of the phase controlled rectifier and Seven- level inverter. Gate driver circuit is used to efficiently drive the switches in the phase controlled rectifier and Seven-level inverter. LCD is used to display the current and set temperature [3].

3] Variable frequency drive in irrigation system

In irrigation application VFD helps farmers to control or vary the pressure of the flow according to the requirements. It is possible to manage various variations in flow.

1. Single pump with multi head duty points

VFD can be used to irrigate different areas having different requirements of water flow. VFD can be used in most of the different irrigation systems from micro/drip to sprinklers and centre pivots. In fixed block systems such as micro irrigation, the irrigated area can be divided into number of zones and each one can have a different pressure requirement. For example, if there are different zones requiring different pressure levels then VFD will change the pump speed at the requirement of the valves as they operate in their respective zones. Following figure shows single pump with multi head duty points.



Fig.4 Pump with multi head points

International Journal of Innovative Research in Science, Engineering and Technology

(An ISO 3297: 2007 Certified Organization)

Vol. 5, Issue 3, March 2016

Fig.4 shows the motor connected with the VFD to irrigate different areas having different water flow requirements. It is possible to adjust the flow of water using VFD. This method is widely used in irrigation purpose.

2 .Pumping with multi flow

In many applications if there is requirement of change in flow of water it can be possible by using the VFD. There are many applications which require more than two motors connected in same application but requires different speed .So in this case VFD helps to keep pressure constant. If there are two pumps in parallel, it is possible to use two variable frequency drives and allow them to cascade. This means when pump 1 exceeds its flow and the pressure condition can no longer be met as it is pumping too far to the right on the pump curve, the 2nd VFD can be called in and then the 2 pumps will balance out in flow and supply what is required at the determined pressure. As the flow increases or decreases, the pumps will ramp accordingly until the flow decreases and the 2nd pump is no longer needed and it will fall out and only pump number 1 will operate.

III. CONCLUSION

VFD helps to save energy in many applications. It is a power conversion device. It converts a basic fixed frequency to a variable frequency, variable voltage output. This fixed output voltage is used to control the speed of induction motors. Primary function of a VFD in a aquatic application is to provide energy savings. By controlling speed of a pump rather than controlling flow through use of throttling valves, energy savings can be substantial.

A VFD is used for control of process temperature, pressure or flow without use of a separate controller, Suitable sensors and electronics are used to interface driven equipment with it. Also maintenance costs can be lowered, since lower operating speeds result in longer life for bearings and motors.

REFERENCES

- [1] Tamal Aaditya, "Research to study variable frequency drive and it's energy savings", IJSR, ISSN :2319-7064, Vol. 2, Issue 6, pp.253-256, June 2013.
- [2] Amresh kumar Ray, Kaushal Prasad, Nitish Kumar, "The application of Variable frequency Drive as an efficient control element in cement industry", IJES, ISSN(e):2319-1813, ISSN(p):2319-1805, Vol.2, Issue 8, pp.50-56, 2013.
- [3] R.Charlet Priya, "Variable Frequency Drive Induction Motor in Air Conditioner Using seven-level inverter", IJAREEIE, ISSN(online):2278-8875, Vol. 3, Issue 4, pp.12-19, May 2014.
- [4] Devraj Jee, Nikhar Patel, " V/f Control of Induction Motor Drive", pp.1-47, May 2013.
- [5] Sayali T. Nadhe, Supriya N. Lakade, Ashwini S. Shinde, "Up gradation of overhead crane using VFD", IJAREEIE, ISSN(online) :2278-8875, Vol. 3, Issue 3, pp.7816-7822, March 2014.
- [6] Neetha John, Mohandas R, Suja C Rajappan, "Energy Saving Mechanism Using Variable Frequency Drives", IJETAE, ISSN 2250-2459, Vol. 3, Issue 3, pp.784-790, March 2013.
- [7] Mr. Ankur P. Desai, Mr Rakesh J. Motiyani, Dr. Ajitsinh R. Chudasama, "Energy conservation using Variable Frequency Drive in Pumping application", IJEDR, ISSN: 2321-9939, pp.121-126, January 2014.
- [8] <http://www.gozuk.com/blog/vfd-basics-864930.html>