

Study and Development of Prototype Continuity Checking System for the Readout Strips Panel of RPC Detector

N. Marimuthu¹, A. Kumar², M. K. Singh³, V. Singh⁴PhD Student, Department of Physics, Banaras Hindu University, Varanasi, Uttar Pradesh, India¹PhD Student, Department of Physics, Banaras Hindu University, Varanasi, Uttar Pradesh, India²PhD Student, Department of Physics, Banaras Hindu University, Varanasi, Uttar Pradesh, India³Assistant Professor, Department of Physics, Banaras Hindu University, Varanasi, Uttar Pradesh, India⁴

ABSTRACT: The India based Neutrino Observatory collaboration needs such an automatic device so that, using it we can check the continuity of readout strips panel with accuracy and in minimum time. We developed a prototype continuity checking system for the RPC detector readout strips panel. In which we make use of basic principle of continuity tester circuit to measure the resistance between two ends, and design and develop an automatic system. Studies about the quality of performance of the continuity checking system have been performed. In the present paper we will explain in detail the prototype system developed and results of its performance.

KEYWORDS: INO-ICAL, RPC Detector, Readout strips panel, Continuity check, Arduino-uno microcontroller.

I. INTRODUCTION

The India based Neutrino Observatory (a multi institutional collaboration of India) is going to build an underground laboratory, for doing basic science research especially in the field of neutrino physics [1]. This will use Iron Calorimeter detector of total weight 51 kton and about 30,000 number of Resistive Plate Chamber (RPC) as active Detectors. Each of these RPC detectors will need two readout strips panel; therefore there will be around 60,000 readout strip panels to be used in it [2]. We have prepared the 1 m × 1 m readout strips panel in our laboratory. In making of readout strips panel we have used a fire retarded dielectric material called as Silicon Fiber Sheet [2]. In readout panel the readout strips are made up of copper and the other side of it is used as ground surface made up of aluminium sheet. These metallic foils we have attached on Silicon Fiber Sheet using a very effective bluecoat 9000 adhesive [3] suitable for the experimental requirements. Of these readout strips panel, one end is terminated with 50 Ω resistances and from other end we take the signals induced on it by RPC gas chamber. Because if we want to avoid any signal which should not overlap with originally produced signal then that signal must be terminated and termination must be in such a way that there should not be any reflected back signal from other end of the readout strips panel. It is only possible if the readout strips will be terminated with their characteristic impedance value. For this purpose we have measured its characteristic impedance using the principle of termination and found that it is around 50 Ω [5]. This we also want, because INO will use the 50 Ω frontend electronics (for signal processing). Each of these readout strips panel having dimension 2 m × 2 m, has around 264 connections in terms of signal connectors, terminators and their ground connections. This means that there will be approximately 15.84 million connections that must be checked before the full phase of INO experiment's installation and running. Since, loose connections will lead to the improper working of readout strips and hence readout panels too. This will finally cause to the less number of neutrino events captured by the ICAL detectors.

II. RELATED WORK

Successful operation of any experiment requires that, its each and every connection must be properly connected and long lasting. But soldering on Aluminium surface is not easy. Therefore under the proper methodology we have used

International Journal of Innovative Research in Science, Engineering and Technology

(An ISO 3297: 2007 Certified Organization)

Vol. 5, Issue 3, March 2016

the Ansol Aluminium soldering flux, and we found that it works satisfactorily [4]. Checking the continuity of large number of connections in pickup panel by manually will consume much time and man power along with compromise with accuracy. Therefore, it will be better to check the continuity using a continuity tester with the help of suitable automated methods. Keeping the need and requirement of the experiment in mind we have designed and developed a suitable method. With the developed method one can measure the continuity of readout strips panels. This method is also useful in making storage of data and in showing the status of readout strips panel online. We developed a 35 cm × 62 cm prototype continuity checking system for doing the above discussed purpose. With the help of the prototype system we are able to check the continuity (or connectivity) of connections. In near future we will develop a full-fledged 2 m × 2 m automated continuity checking system [6].

III. OP-AMP BASED CONTINUITY TESTING CIRCUIT

Since, the readout strips panels are terminated with 50 Ω resistances therefore; the continuity checking circuit should be able to measure the resistances below the terminating resistance value. Hence, common multimeter will not be suitable for this purpose and this forced us to develop some other continuity checking circuit. In this trial, initially we have developed an OP-AMP circuit, which was able to produce such a continuity tester which can measure the low resistance (0.25 Ω to 4 Ω) values, which is required for the connectivity check of 50 Ω resistance terminated readout strips [7]. This OP-AMP's circuit uses IC-741 in differential mode which is able to provide large input impedance and amplified output with very low noise.

The design and developed continuity tester circuit as shown in figure 1, is of very low price and is able to check the continuity between the soldering points at a very fine level. From figure 1, one can see that there are two resistances one of 470 kΩ and another of 10 kΩ connected with the inverting and non-inverting terminals. If the inputs of OP-AMP can be made in such a way that they are ideally equal with the help of these two resistors then the circuit will be balanced. In balanced condition there will be zero output from the probes which cause to produce zero potential difference. If we use the circuit shown in figure 1 for continuity checking purpose in readout strips panel, the resistances 470 kΩ and 10 kΩ will produce a very less amount of potential difference which will be applied to the inputs of OP-AMP. Finally the amplified potential difference (output of OP-AMP) will leads the Light Emitting Diodes (LED) to glow.

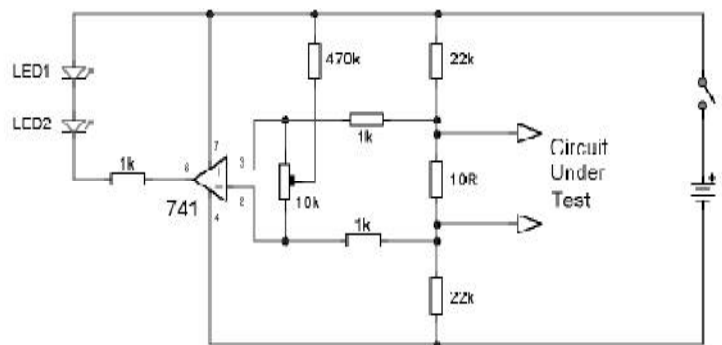

Fig.1 An IC-741 based OP-AMP continuity tester circuit [6].

During application of the proposed circuit, we observed some draw backs in using IC-741 based OP-AMP continuity tester circuit. First of all the proposed circuit is complicated and using such circuit is not convenient for every readout strips. The most severe drawback of this circuit is that it hangs frequently during operation may be due to the inverting and non inverting resistances sometimes can't provide a minimal potential difference to the inputs of OP-AMP therefore circuit will be unable to amplify this potential difference which does not lead the LED to glow and hence it failed. Therefore, we discarded the circuit design as shown in figure 1.

International Journal of Innovative Research in Science, Engineering and Technology

(An ISO 3297: 2007 Certified Organization)

Vol. 5, Issue 3, March 2016

IV. GENERAL MULTIMETER BASED CONTINUITY CIRCUIT

Measurement of continuity can be easily done by using the general audible multimeter. But there are some difficulties in using the general multimeter for current purpose. Because, the resistance between two probes of general multimeter are greater than 100 Ω, so it is unable to check the continuity of readout strips panel which is terminated with 50 Ω. Also the general multimeter is not cost effective, larger in size and one of the most important disadvantages of using general multimeter for current purpose is that we need large number of them because one multimeter will be required for each strip and there are sixty six strips in a readout panel. Another disadvantage of using general multimeter is that they are unable to store the continuity data for further analysis.

Therefore to solve these problems for our case, we have designed a multimeter based continuity tester circuit, which is able to measure the relatively less resistant continuity circuit. This continuity circuit has only one job to measure the continuity between two ends. This continuity circuit as shown in figure 2 is taken out from the general multimeter and therefore we can use it also at large scales for every strip.

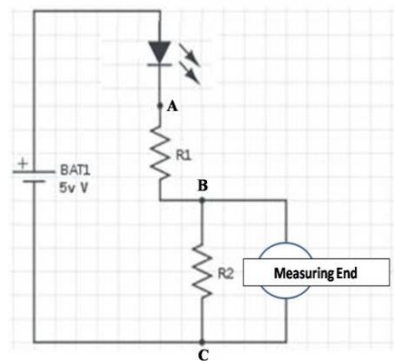

Fig. 2 A simple continuity circuit [6].

This circuit is commonly used in multimeter for the measurement of resistance, current, voltage and continuity. For the resistance measurement, the basic principle involved is to keep R_1 value at a fixed minimum value ($\sim 0.1 \Omega$) and the R_2 value is unknown. According to the Ohm's law [8], in any circuit current (I) is

$$I = \frac{V_{\text{Known}}}{R_{1 \text{ Known}}} \dots\dots\dots (1)$$

$$R_{2 \text{ Unknown}} = \frac{V_{\text{Known}}}{I_{\text{Known}}} \dots\dots\dots (2)$$

From equation 2 we can easily know the $R_{2 \text{ Unknown}}$ value. In the same circuit, if R_2 resistance is not connected properly with R_1 then the circuit will be open and therefore it will not give any output current due to the value of $R_{2 \text{ Unknown}}$ will be infinite and correspondingly the LED (Light emitting diode) will not glow, which indicates that there is no continuity in the circuit. This is the basic principle of resistance measurement and continuity checking by using the design circuit as shown in figure 2. But our main motive is to check continuity of each readout strips at a time. In figure 2 point B is considered as the Copper strip and point C is considered as the ground of readout strip which is made up of Aluminium sheet. Therefore the circuit will be open if terminator is not properly connected in between points B and C. In case of readout strips panel, the value of $R_2 = 50 \Omega$ (terminator resistance value connected with readout strips). So, if it is connected properly between readout strip and ground (GND) then LED will glow otherwise not. Therefore by simply looking at the glow of LED we can determine which strip is not properly terminated.

International Journal of Innovative Research in Science, Engineering and Technology

(An ISO 3297: 2007 Certified Organization)

Vol. 5, Issue 3, March 2016



Fig. 3 Continuity checking of readout strips [9].

The designed and discussed circuit is developed on breadboard (just as initiative) as shown in figure 3. We tested the circuit for its functionality for good enough number of times. It observed that the designed circuit is working satisfactorily. For the said purpose we used just a single strip and since it is working well in checking continuity therefore we have preceded with it in making the prototype of the dimension 35 cm × 62 cm for checking the continuity of readout strips panel.

V. CONSTRUCTION OF PROTOTYPE AND ITS WORKING METHOD

Since general multimeter based continuity checking circuit operation is satisfactory, therefore, we have moved forward in making prototype that may check continuity of eight strips at a time using the principle as discussed in section III. In making prototype as shown in figure 4, we used Aluminium frame with a wooden rod fixed on its right side. On the top of the rod, there are adjustable plastic clips to fit the readout pickup strips panel properly according to the distance of soldering point from the edge of the pickup readout panel. The tips of the clip have been made of metal. The readout strips have pitch of 30 mm i.e. 28 mm Copper strip's width and 2 mm spacing. The spacing between the clips is in such a way that each clip is covering each strip.

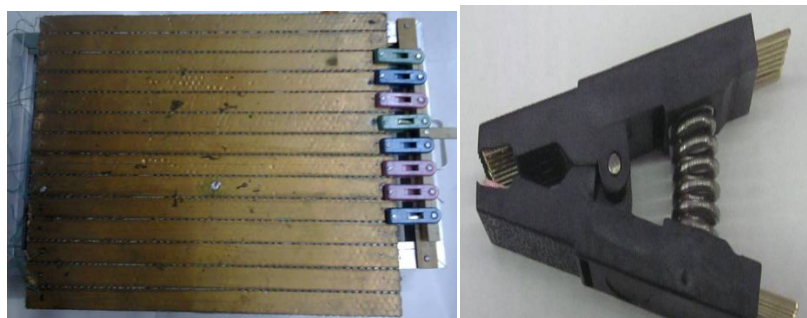

Fig. 4 Prototype of size 50 cm × 50 cm and a plastic clip with metallic tip [10] [11].

For terminating the signals at one end of readout strips panel we use 50 Ω resistances, since we have measured and found that the characteristic impedance of readout strips panel is 49.7 Ω [5]. Figure 4 shows the image of prototype continuity tester and the plastic clip with metallic tips. The plastic honeycomb based readout pickup strip panel is placed in the developed continuity tester in figure 4 and the tester setup is placed on the Aluminium frame. In future the aluminium frame will be converted into a big plate form of dimension 2.25 m × 2.25 m well equipped with conveyer-belt attached with electric motors so that full flagged readout pickup strips panel (2 m × 2 m) of RPC detector for INO-ICAL experiment will accommodate properly.

The continuity circuit will be connected to the one end of these clips and the other end (top side of each clip) will be connected to the LED for getting visual information of connectivity. For checking the continuity of any readout strips panel, we place it in the jaw of these adjustable clips. Each clip will connect with each strip of the panel. Therefore if

the continuity between Copper (readout strips) and Aluminium (GND of readout strips) is good then the LED will glow otherwise not. But some time LED glows in short time due to some unwanted connections. Therefore we need a constant output, which can confirm the continuity of readout strips. For this purpose we add the output of readout strips with TTL logic 7415 through LED; because, the TTL will provide the output constantly if the input is more than 2 V.

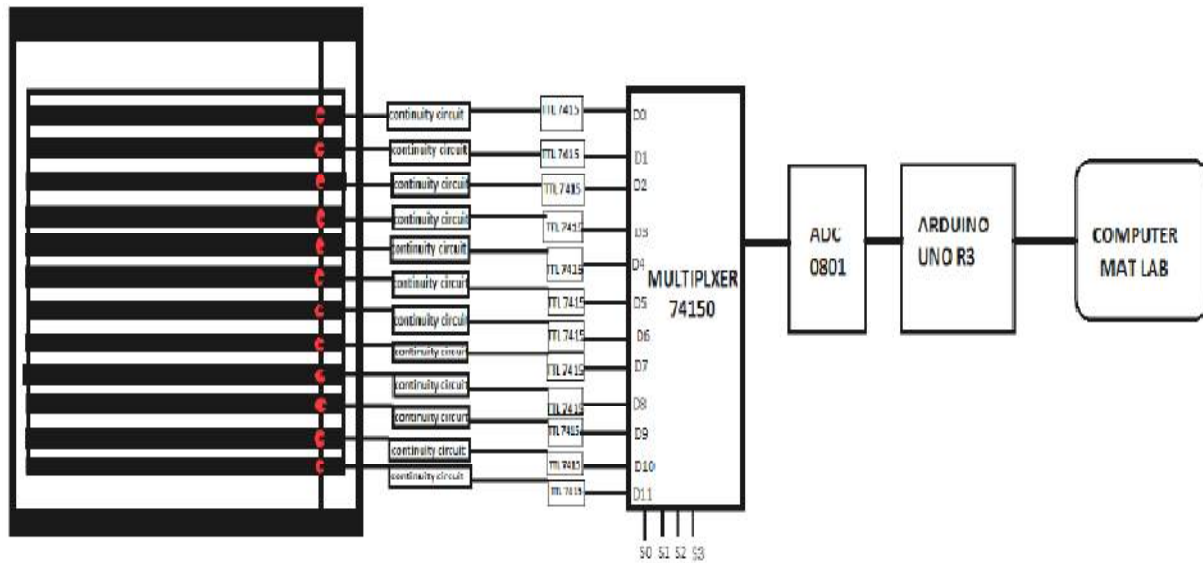

Fig. 5 Schematic block diagram of continuity checking system for each strip [6].

Schematic block diagram of continuity checking system of present prototype is shown in figure 5. The output of the TTL (7415) is connected with a multiplexer SN74150, which has single output for sixteen inputs. The output of it is connected with an analog to digital converter-0801; the digitized signal is further connected with a microcontroller circuit (Arduino-uno) for making interface with the personal computer. With the help of Matlab software it can easily store the information about the continuity of readout strips in the computer.

VI. CONCLUSION

Using the above mentioned prototype continuity method we are able to get the information about whether the strips are properly connected with the 50 Ω resistances or not. In this measurement process we observed that, this method takes very less time, which we want. This method provides the continuity information at a very low cost which means our developed method is cost effective. Most important achievement of this method is that, by using this method we are able to avoid the unwanted fluctuations in voltage through TTL logic gates. By our developed method we are able to display the continuity status of readout strips panel on the personal computer. Therefore, we conclude that our developed method is working satisfactorily and India based Neutrino Observatory can make use of it in checking the continuity of such a huge number of readout strips at very less price and in very less time.

ACKNOWLEDGEMENT

Authors are grateful to the Department of Science and Technology (DST), New Delhi for providing financial support and India-based Neutrino Observatory (INO) Collaboration for their continuous support and fruitful discussions. Author N. Marimuthu is very much thankful to Prof. Satyanarayana Bheeste (TIFR, Mumbai) and Dr. Vivek Singh (Department of Physics, BHU) for giving proper, continuous and fruitful suggestions which makes our work successful.

International Journal of Innovative Research in Science, Engineering and Technology

(An ISO 3297: 2007 Certified Organization)

Vol. 5, Issue 3, March 2016

REFERENCES

- [1] The ICAL Collaboration: Shakeel Ahmed, M. Sajjad Athar, Rashid Hasan, Mohammad Salim, S. K. Singh et al., "Physics potential of the ICAL Detector at the India based Neutrino Observatory", arXiv: 1505.07380 [physics.ins-det].
- [2] M. K. Singh, A. Kumar, N. Marimuthu, V. Singh, V. S. Subrahmanyam, "Characterization of Silicon Fiber Sheet for making the readout strips Panel", IJRSET, Vol. 4, No. 10, pp. 10035-10042, October 2015.
- [3] A. Kumar, M. K. Singh, N. Marimuthu, V. Singh, V. S. Subrahmanyam, "Search of Suitable Adhesive for attachment of metallic foils in making the readout strips panel of RPC Detector.", IJRSET, Vol. 5, No. 1, pp. 1101-1106, January 2016.
- [4] A. Kumar, M. K. Singh, N. Marimuthu, V. Singh, V. S. Subrahmanyam, "Development of suitable method in connecting wires for Resistive Plate Chambers", IJRSET, Vol. 4, No. 11, pp. 10766-10773, November 2015.
- [5] M. K. Singh, A. Kumar, N. Marimuthu, V. Singh, V. S. Subrahmanyam, "Measurement of characteristic impedance of Silicon fiber sheet (Ceramic foam) based read out strips panel", Proceedings of DAE Symposium on Nuclear Physics, vol. 60, pp. 948-949, December 2015.
- [6] N. M. Muthu, A. Kumar, S. Shree, M. K. Singh, D. Grover et al. "An automated scheme for continuity checks of the 50 Ω terminated end of RPC Pickup panels", Proceedings of the DAE Symposium on Nuclear Physics, vol. 59, pp. 938-939, December 2014.
- [7] www.zen22142.zen.co.uk/Circuits/Testgear/connectiontester.htm
- [8] R. D. Knight, Physics for Scientists and Engineers: A Strategic Approach (With Modern Physics), 3rd edition (2012), See section 30.5, Pearson Education.
- [9] N. M. Muthu, A. Kumar, M. K. Singh, V. Singh, V. S. Subrahmanyam; "Automatic system for continuity checks of the RPC detector's Pickup panels", Poster presented in International Conference on Contemporary Advances of Science & Technologies (IC-CAST), August 07-09, 2015, Banaras Hindu University, Varanasi-221005, India.
- [10] N. M. Muthu, A. Kumar, M. K. Singh, V. Singh, V. S. Subrahmanyam; "Automatic method for continuity checks of the RPC detector's Pickup panels", Poster presented in National Conference on Recent Trends in Nuclear Physics, February 15-16, 2016, at Department of Physics, Aligarh Muslim University, Aligarh- 202002, India.
- [11] <http://www.aliexpress.com>, Programmer Testing Clip Sop16 Soic 16 Dip 16 Pin Ic Test Clamp.

BIOGRAPHY



[1]

[2]

[3]

[4]

[1]: N. Marimuthu, [2]: Abhishek Kumar, [3]: Manoj Kumar Singh, [4]: Dr. Venkatesh Singh [Corresponding Author, Email Id: venkaz@yahoo.com].

Authors N. Marimuthu, Abhishek Kumar and Manoj Kumar Singh and are pursuing their PhD in Experimental High Energy Physics, from Department of Physics, Banaras Hindu University, Varanasi 221005, INDIA.