

# Active Power Factor Correction for DC-DC Converter

Arpit D. Patel<sup>1</sup>, Hardik Pandya<sup>2</sup>

P.G. Student, Department of Electrical Engineering, SCET, Surat, Gujarat, India<sup>1</sup>

Associate Professor, Department of Electrical Engineering, SCET, Surat, Gujarat, India<sup>2</sup>

**ABSTRACT:** Clear view of need of power factor correction is explained here. Bridgeless single phase DC-DC active power factor correction rectifier based CUK topology is described. It is also discussed the conventional types of power factor correction methods employed by the use of power electronic converters. This topology is operating into continuous (CCM) or discontinuous (DCM). By doing the power factor correction we get power factor nearer to unity and input current with low harmonics. Here we use CUK converter for power factor correction due to some advantages. Power supplies with power factor correction (PFC) is becoming necessary form many industrial purpose to meet harmonic regulation and good power quality.

**KEYWORDS:** DC-DC Converters, Power Factor Correction Techniques, THD, MATLAB

## I. INTRODUCTION

In recent years Switch Mode Power Supply technologies (SMPS) are developed rapidly. In different application SMPS supplies are used as AC to DC sources for electronics products. But main disadvantages of this off line SMPS is that it draws a pulsating current so it has low power factor and high RMS line current. So, due to increasing demand of high power factor and good power quality Power Factor Correction is important part. Active Power Factor Correction (APFC) for DC-DC converters is economical and efficient.

In [1] they discussed the different DC-DC converters topologies and their advantages and disadvantages. As these DC-DC converters are worked as a non-linear load so it is important to effect of non-linear load [2] and about harmonics and need of improving power factor. When DC-DC converters are operated in discontinuous conduction mode they have a self-power factor correction property which is described in the [3]. Method of improving power factor is active power factor correction which has different types with their own advantages and disadvantages [4]. The problem of low power factor can be improved by the power factor correction techniques. There are different power factor correction techniques here this paper discussed peak current control method [5].

Power converter with PFC works with high frequency and it draws a sinusoidal AC current which is in phase with AC input voltage. This APFC method is interposed between AC main and DC load. And non-linear load is appearing as a linear load for the AC line.

The main objective of this paper is the Power Factor Correction for CUK converter. If power factor of the system is poor then large amount of current is drawn from the supply. So, the power factor correction is essential in power system to achieving good power.

Advantages of CUK converter over other DC-DC converters are that output of Buck converter is always less than input and it requires an additional passive filter and output of buck converter is discontinuous and input current does not follow line voltage at zero crossing.

When Boost and SEPIC converters are operated the output of both converters are discontinuous with high ripple.

The drawback of Buck-Boost converter is when it operated there is high current stress on semiconductor devices and discontinuous input current which increase the THD.

Compare to other converters cuk converter gives continuous input and output current with low current ripple and due to these advantages CUK converter is best candidate for the power factor correction.

Over this advantages cuk converter it has some disadvantages that output of CUK converter is negative so it required extra inverse amplifier circuit and Conduction losses are increase because it is a four quadrant converter and more components are comes to the operation when current flow from input to output side.

# International Journal of Innovative Research in Science, Engineering and Technology

(An ISO 3297: 2007 Certified Organization)

Vol. 5, Issue 3, March 2016

## II. RELATED WORK

Due to the non-linear relationship of voltage and current all types of converters are producing harmonics. This harmonic distortion in current waveform will lead to poor power factor. Poor power factor increase the value RMS current, but the power delivered is small. So it is important task to improve power factor and reduce harmonics distortion to achieve good quality power. The parameter of cuk converter is given in Table 1. And Waveform obtain from this parameters are as shown in figure 2 and figure 3.

Simulation Parameters	Values
Input Voltage	40 V
Frequency	50 Hz
Inductor L1	3 mH
Inductor L2	3 mH
Capacitor C1	2 $\mu$ F
Capacitor C2	1000 $\mu$ F
Load	100 $\Omega$
Switching Frequency	20 KHz
Duty Cycle	70%
Output Voltage	100 V
Output Current	1 A

Table 1.Simulation Parameters

. Power factor can be calculated by the equation:

$$P.F. = \frac{1}{\sqrt{1+THD^2}} * \cos \alpha$$

Where  $\alpha$  is displacement factor at fundamental frequency and THD is Total Harmonic Distortion in input current.

So to improve the power factor power factor correction method is used.

Power factor correction method is to improve power factor by suitable devices. The objective of power factor correction circuit is to make input power supply behave like purely resistive load.

There are two methods of Power factor correction methods:

Passive Power Factor Correction Method

Active Power Factor Correction Method

Passive Power Factor Correction Method is used to improve the power factor for non-linear load. In this method we use only passive elements like capacitors and inductors to improve the nature of line current. But the size of passive elements will increase as the level of voltage is increase. And this method is used to improve power factor only up to 0.9. To 0.9, this is not used for industrial application.

Another important method to improve power factor is Active Power Factor Correction Method (APFC). This method is based on switch mode converter technique and is designed to compensate for distortion as well as displacement of input current waveform. Main advantages of this method is that we can improve power factor up to 0.99 by using this method and automatic correction of AC input voltage can be obtained.

There are four different methods of APFC as bellow:

- (1) Peak current control method.
- (2) Hysteresis current control method.
- (3) Average current control method.
- (4) Border line current control method.

In this paper we discussed Peak current control method of APFC for improving the power factor for DC-DC cuk converter.

In this method switch is turned on at constant frequency which is controlled by a clock signal, when the positive ramp of inductor current and external ramp reaches to the reference current the switch becomes turned off. Reference signal is sinusoidal current which is obtained by the multiplying replica of rectified line voltage time the output of the voltage error amplifier. This reference signal is the condition to obtain unity power factor.

Advantages of Peak current control method:

- (1) Constant switching frequency.
- (2) No need of compensation ramp.
- (3) Only switch current must be sensed and this can be accomplished by a current transformer.

Disadvantages of Peak current control method:

- (1) Need of compensation ramp.
- (2) Input current distortion increase at high line voltage and light load is distorted by a compensation ramp.
- (3) Control is more sensitive to commutation noise.

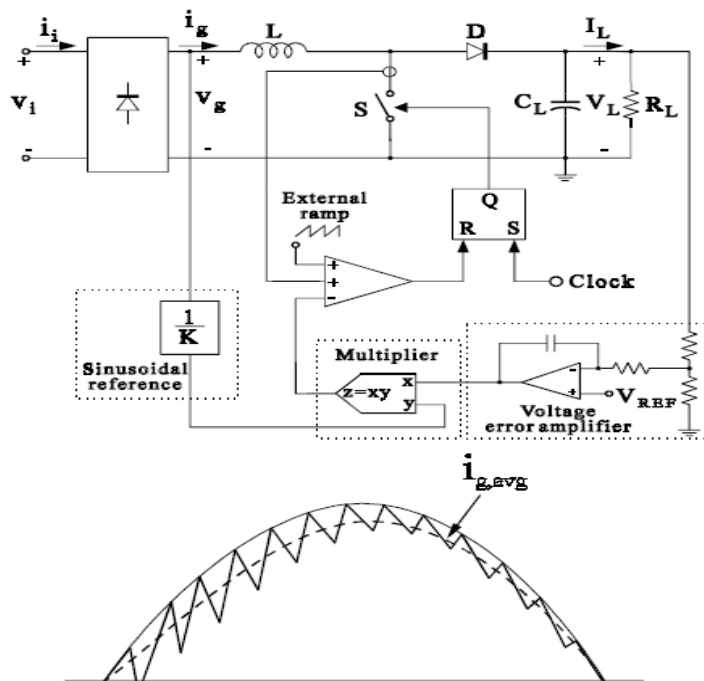

Fig.1 Peak current control

### III. SIMULATION MODEL

From parameters which are given in Table we got output voltage is as shown in Figure 2.

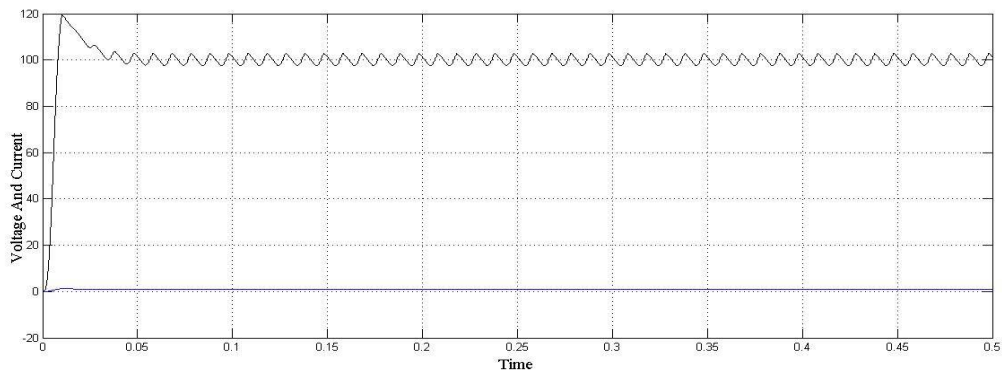

Fig. 2 Output Voltage and current of cuk Converter

## International Journal of Innovative Research in Science, Engineering and Technology

(An ISO 3297: 2007 Certified Organization)

Vol. 5, Issue 3, March 2016

When the cuk converter is operated without power factor correction it draws high input current with high ripple. And input line current and voltage is also not in phase and it has low power factor which is undesirable for industrial application. The THD analysis for input current is given in Figure 3.

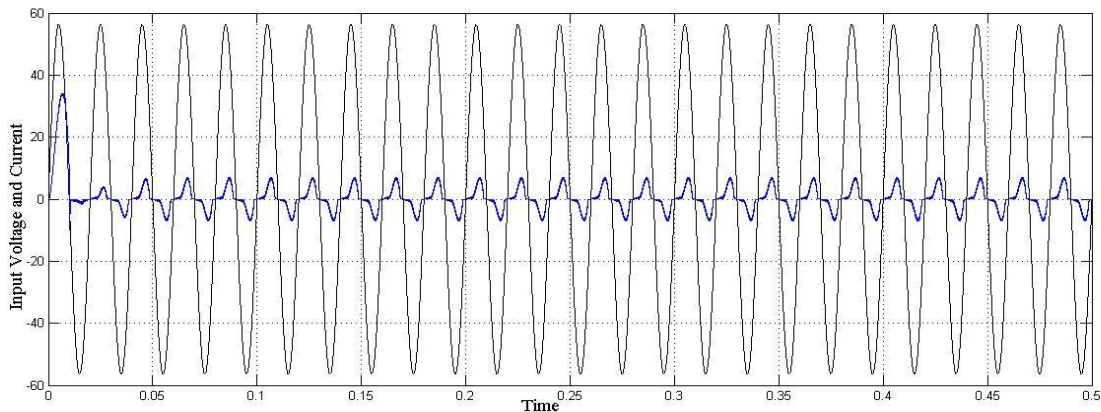

Fig.3 Input Current and Voltage Waveform

We can see that the without power factor correction there is a high harmonics in input current up to 55.21%. And power factor is also not unity. From Equation we can calculate the power factor which is 0.8128 which is not unity.

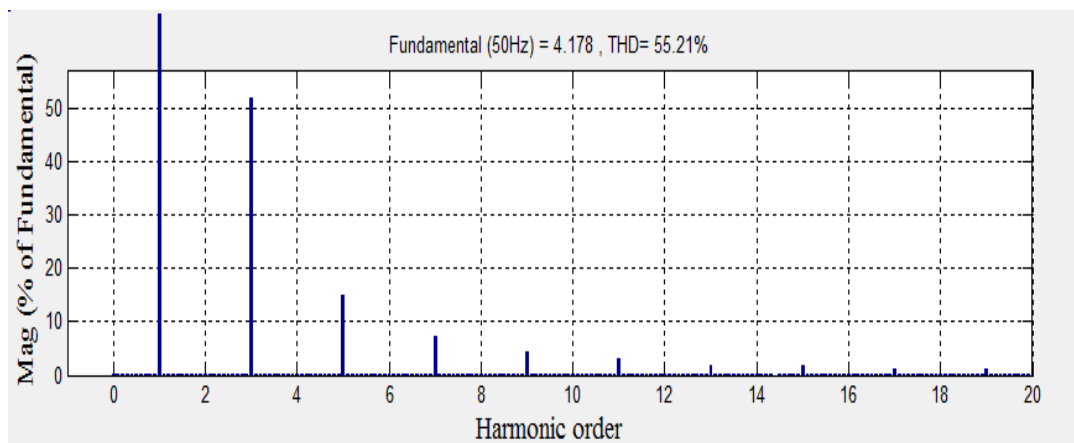

Fig.4 THD analysis in cuk Converter

In MATLAB/SIMULINK, the model of cuk converter with peak current control is built and all parameters for converter are same as given in Table 1. In figure 5 the cuk converter with peak current control method is built in closed loop. Clock is used to give constant switching frequency by using we can turn on the switch. PID controller is used for the close loon to measure the error. In this model output voltage is 100 V and Current is 1 A. By the simulation result we can see that harmonics in line current is reduced and the input line current and voltage is in phase with each other so the power factor is also increased. Waveform for the line current and voltage is shown in figure 6.

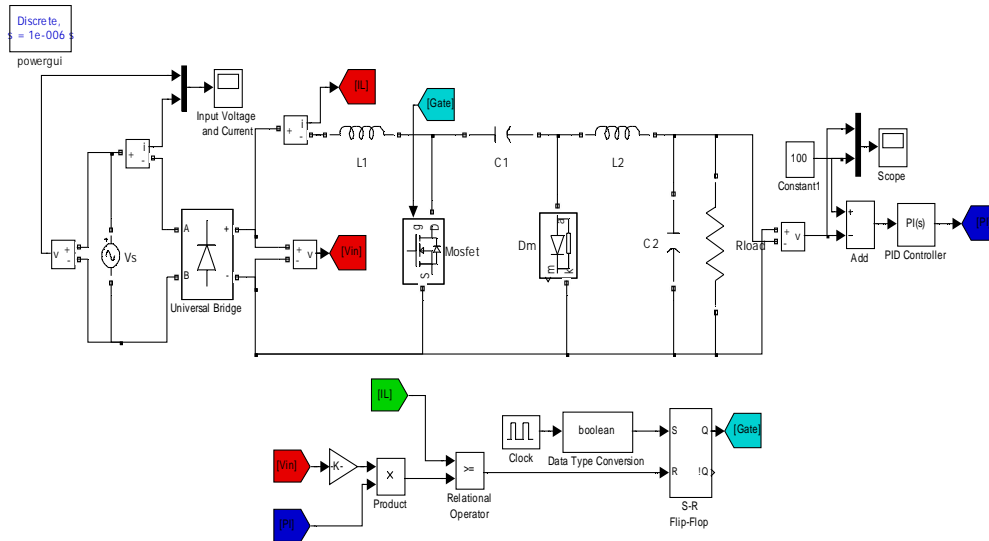

Fig. 5 Simulation of cuk converter with peak current control method

Input voltage and current is shown in figure 6. As shown in figure both voltage and current waveform is in phase with each other. By using this method the harmonics are also reduced from line current.

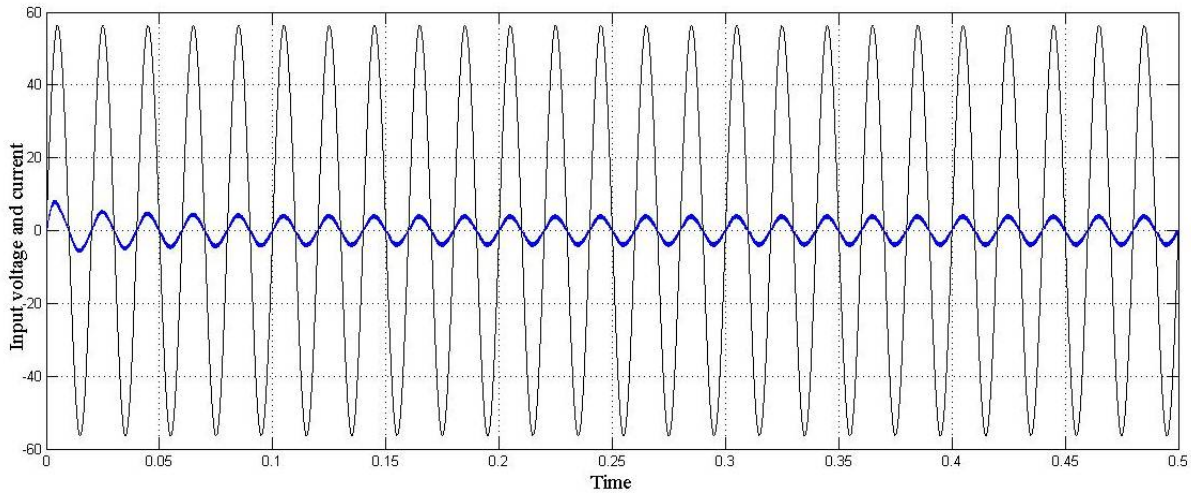

Fig. 6 Input voltage and current waveform for cuk converter with peak current control

THD analysis is given in Figure 7. As shown in figure 8 only 5.79% harmonics are introduced in line current which is less than the harmonics of line current of cuk converter without PFC. and if the power factor is calculated from equation it is 0.99807 which is nearer to unity.

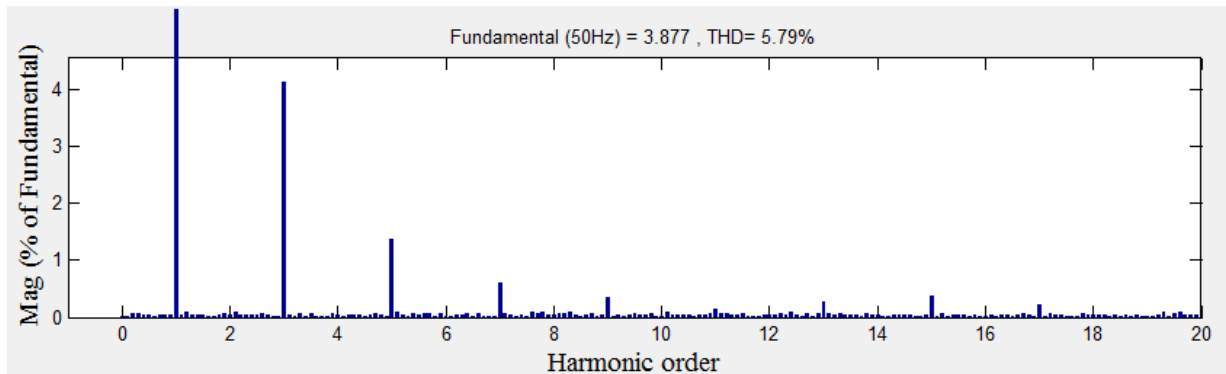

Fig. 7 Input current THD for Open-loop configuration

#### IV. CONCLUSION

This paper discussed the detailed study about the harmonics and effect of non-linear load (DC-DC converter) on input line current and on power factor. Due to low power factor input line current has high harmonics and it is not in phase with the input line voltage so power factor is poor and it will draw pulsating line current. To overcome this problem power factor techniques are used which is also discussed in this paper. By using peak current control technique the input line current follows the input line voltage and unity power factor theoretically which is showed in MATLAB simulation in this paper.

#### REFERENCES

1. H.T.Yang, H.W.Chiang, C.Y.Chen," Implementation of Bridgeless Cuk Power Factor Corrector with Positive Output Voltage," IEEE conference Power electronics, pp.2100-2107, May 2014.
2. D.Reddy, K.Pavankumar Goud, Pradeepkumar Reddy," Analysis Of Different Topologies For Active Power Factor Correction Using DC-DC Converters," IJATER, vol.4, Jan.2014.
3. H.Wei, I.Batarseh,"Comparison Of Basic Converter Topologies For Power Factor Correction," IEEE conference, pp.348-353,1998.
4. L.Rossetto, G.Spiazzi, P.Tenti," Control Techniques For Power Factor Correction Converters," Proc. PEMC'94- 9, 1994.
5. M. Subbarao, Dr.Ch.Sai Babu, Dr.S.Satyanarayana, S.L.V SRAVAN KUMAR," Analysis and Design of Peak Current Controlled IBFC For High Power factor andTight Voltage Regulation,"IEEE conference, page 1-4, DOI: 10.1109/ICAEE.2014.6838487