

International Journal of Innovative Research in Science, Engineering and Technology

(An ISO 3297: 2007 Certified Organization)

Vol. 5, Special Issue 8, May 2016

Effect of Springback in Tube Bending Process and Application of ANN for Overbend Angle Determination - A Review

S.Manoj

Assistant Professor, Department of Mechanical Engineering, TRP Engineering college, Trichy, India

ABSTRACT: Tubes which are hollow cylinders are widely used in various fields nowadays. Minimization of materials and reduction in self weight are the major factors which makes the engineers to turn their way towards hollow cylinders. In automobiles solid components are being replaced by hollow components. Hollow components are generally bent to obtain the desired shape. So the geometry of bent tubes plays a vital role. Hence we go for analysis of tube bending to obtain precision components. Springback is the major issue in the bending of tubes. Presently trial and error methods are followed in the production of components for compensating the springback problem. This takes an ample amount of time and money for the industries. More quantity of components gets rejected due to this problem. So this makes the companies to go for a solution to this problem. In this paper the springback analysis of hollow cylindrical tubes are carried out. The materials are steel, aluminium and copper, since these materials are widely used in various applications. In this paper artificial neural network is proposed in which initial parameters are fixed to get desired final shape. An experimental method of bending the tubes can be done to obtain the initial parameters. ANN can be used for determining overbend angle.

KEYWORDS: Springback, ANN, Bending, Tubes, Easy-NN plus software.

I. INTRODUCTION

Today, the hollow structural members are widely used instead of the solid ones in manufacturing industry, and have a good developing trend in future. In the report of American Iron and Steel Institute (AISI), the proportion of light hollow members in the typical autos made in North America has been raised to 16% from 10% in the past fifteen years. Now, General Motor Corporation (GM) has made many light hollow members, including the engine cradle, the radiator cradle, the underbeam, the shed cover joist, the inner support, and so on. The hollow members have a high performance/mass ratio, have a special advantage regarding the stiffness and bearing capacity due to strain hardening effect. The further improvement of the stiffness and intensity of the hollow member would be required to economize material and develop the technology. During the 10th Five-Year Plan period in China, the investment on the railroad industry reached to 350 billion Yuan, and the rails of more than 900000 tons including the replacing rails of about 600000 tons will be used up for repair. The replacement of the rails by the hollow members will be significant to sustainable development. Hollow components are mostly produced by cold working process. Among various methods we will discuss about the bending process in detail. Because bending process is the major concern in this project. The bending is one of the most important cold forming operations applied to the metallic tubes. Looking closer at bending process, it can be observed that the process is confronted with several problems regarding the quality of obtained parts, problems that in condition of continuous growth of beneficiary's requirements must be eliminated. In order to estimate the quality of parts obtained by bent tubes, the below mentioned parameters are considered:

- Cross-section ovality;
- Bend angle error, caused by spring-back phenomenon;
- Wall thickness.

International Journal of Innovative Research in Science, Engineering and Technology

(An ISO 3297: 2007 Certified Organization)

Vol. 5, Special Issue 8, May 2016

II. SPRINGBACK

After the bending process is complete and the tooling have been withdrawn the bent tube springbacks due to the elastic nature of the tube material. This is called springback or the elastic recovery of the tube. During the bending process internal stresses are developed in the tube and upon unloading the internal stresses do not vanish. After bending the extrados is subjected to residual tensile stress and the intrados is subjected to residual compressive stress. These residual stresses produce a net internal bending moment which causes springback. The tube continues to springback until the internal bending moment drops to zero. The springback angle depends on the bend angle, tube material, tube size, mandrel, machine and tooling. In actual practice the amount of springback is calculated and the tube is over bent by that amount. Fig. 1 shows springback after the tooling has been removed.

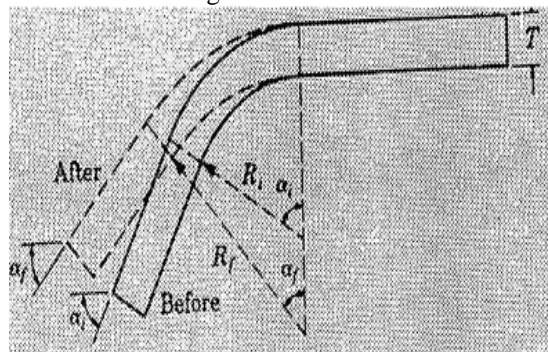

Fig. 1 Springback effect

III. LITERATURE SURVEY

There are several methods available for cold-bending or hot-bending hollow cylinders. But the most popular method is cold bending of hollow cylinders around a mandrel on special tube-bending machines.

Luk'yanov and Zubkov, in their paper investigates bending of tubes in a tube bending machine. Here the work 1 is fitted onto the mandrel 3 and inserted into the groove of the bending roll 5. A clamp is fixed on the bending roll and held down by a guide plate 2 which remains stationary during the tube bending operation.

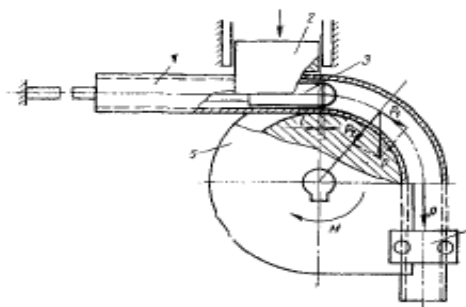

Fig. 2 Tube bending machine using mandrel

The use of mandrel and pressure guide plate in tube bending on a tube-bending machine greatly increases the required bending torque. The reason is that, not only the resistance to purely plastic flow bending of the tube must be overcome in the bending operation, but also the resistance of frictional forces generated at points where the mandrel and pressure plate contact the surface of the work to be bent. Experiments were conducted by using lubricants in the mandrel and removing scales. They also conclude that production of bent tubes with minimized out-of-roundness in the bend zone requires lubrication of the mandrel and guide plate, cleaning of the tube surfaces to remove scale, and setting the mandrel at a 2-3 mm lead relative to the area of deformation

International Journal of Innovative Research in Science, Engineering and Technology

(An ISO 3297: 2007 Certified Organization)

Vol. 5, Special Issue 8, May 2016

Strano (2005) in his paper has suggested a computer-based methodology, called Tube ProDes, for process design of the rotary draw bending of tubes. The minimum tool requirements for the rotary draw bending of tubes are the bend die, the clamp die and the pressure die. When, due to the tube geometry, bending is more difficult, the use of a mandrel and a wiper die might be necessary. Especially when bending long tubes, subsequently assembled into complex parts, trial and error is often required for calculating over bending and to reduce or eliminate the risk of defects (wrinkling, excessive thinning and flattening).

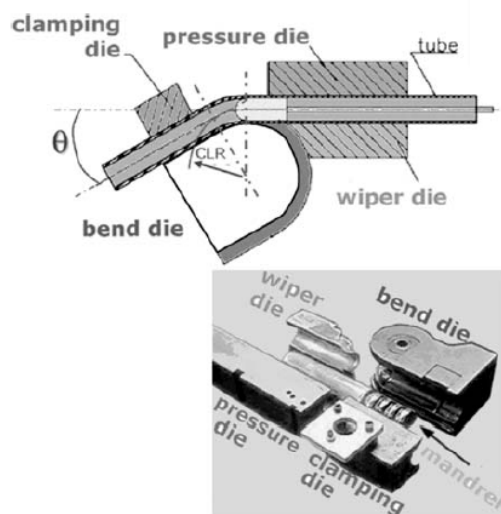

Fig. 3 Rotary draw bending

Therefore, process planning is a critical and experience-based activity that requires the selection of several variables. A comprehensive process design system has been developed by the Università di Cassino, and it is able to automatically perform process design.

The defects occurring while bending are mainly focused since it affects the quality and performance of the part. Various defects which occurs while bending of tubes can be clearly understood from the paper of rohit agarwal (2004). From his paper we understand that during the bending process the tube undergoes considerable in-plane distortion. The limitations in the tube bending process are distortion of cross-section, wrinkling, variation in wall thickness, springback and fracture.

During the bending process the bending moment induces axial forces in the inner and outer fibers. The inner and outer fibers are subjected to compressive and tensile stresses respectively. This results in thinning of the tube wall at the outer section (extrados) and thickening of the tube wall at the inner section (intrados). The wall thickness variation is shown in Fig. 4.

International Journal of Innovative Research in Science, Engineering and Technology

(An ISO 3297: 2007 Certified Organization)

Vol. 5, Special Issue 8, May 2016

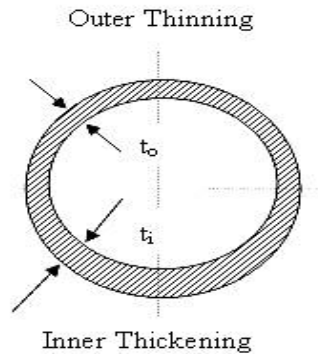

Fig. 4 Variation in wall thickness of the tube

The fibers at the extrados are subjected to tensile stress. When the tensile stress induced in the tube due to the bending moment at the extrados exceeds the ultimate yield strength of the material, the tube fractures at the extrados. As the tube is bent, the inner surface of the tube, the intrados is subjected to compressive stress. When the tube is bent into a tight radius, it is subjected to high compressive stress in the intrados which leads to Bifurcation instability or buckling of the tube.

Wrinkles are wavy types of surface distortions. As tubes are used as parts in many applications where tight dimensional tolerances are desired, wrinkles are unacceptable and should be eliminated. Furthermore, wrinkles spoil the aesthetic appearance of the tube.

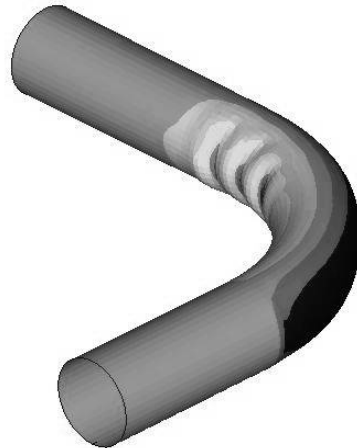

Fig. 5 Tube wrinkling

As described above the outer fibers of the tube are subjected to tensile stress whereas inner fibers of the tube are subjected to compressive stress. There is a tendency of fibers at both the ends to move towards the neutral axis. The outer fiber of the tube tends to move towards the neutral plane to reduce the tensile elongation. This results in the cross section of the tube being no longer circular, instead becoming oval. The common practice in industry is to provide support to the tube from inside to prevent flattening or distortion of cross section; usually a filler material or mandrel is used for that. Fig. 6 shows the cross section distortion of tube.

International Journal of Innovative Research in Science, Engineering and Technology

(An ISO 3297: 2007 Certified Organization)

Vol. 5, Special Issue 8, May 2016

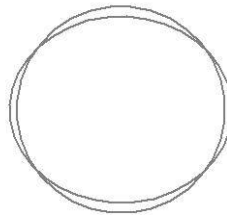

Fig. 6 Cross section distortion

After the bending process is complete and the tooling have been withdrawn the bent tube springbacks due to the elastic nature of the tube material. This is called springback or the elastic recovery of the tube. During the bending process internal stresses are developed in the tube and upon unloading the internal stresses do not vanish. After bending the extrados is subjected to residual tensile stress and the intrados is subjected to residual compressive stress. These residual stresses produce a net internal bending moment which causes springback. The tube continues to springback until the internal bending moment drops to zero. The springback angle depends on the bend angle, tube material, tube size, mandrel, machine and tooling. In actual practice the amount of springback is calculated and the tube is over bent by that amount.

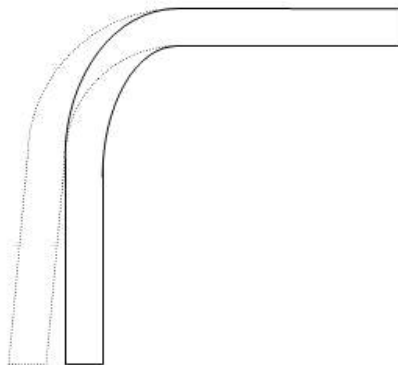

Fig. 7 Springback

Springback effect is the major problem in the forming of components, especially in bending. Various authors have presented papers on springback effect. Mei Zhan et al (2006) in their paper presented a numerical formulation method for compensating springback. In their paper they explain that springback inevitably occurs when the load is released due to the elastic property of the material. This leads to an increase in the radius of curvature and a reduction in the bending angle of the bent tube, as shown in Fig. 8 and further leads to the decrease in the geometric accuracy of the tube part and makes it difficult to fit the tube with others. To improve the quality of the bent tube parts, springback prediction has become an urgent problem to be resolved in the research and development of the process.

International Journal of Innovative Research in Science, Engineering and Technology

(An ISO 3297: 2007 Certified Organization)

Vol. 5, Special Issue 8, May 2016

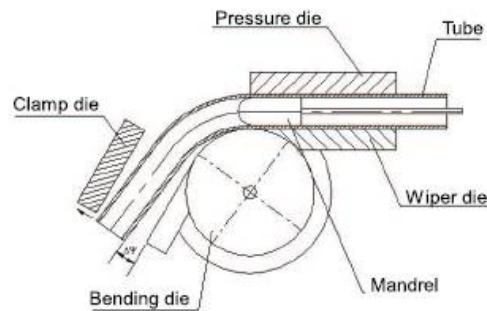

Fig. 8 Springback of a bent tube upon unloading

The mechanism of springback gives an equation for finding the amount of springback. Fig 9 shows the stress-strain characteristics of a linearly strain hardened material. When the material is unloaded from the point A, the path of unloading is given by the line AB, as shown. The amount of recovered strain obviously is

$$\epsilon_{rec} = BC = \sigma_A / E$$

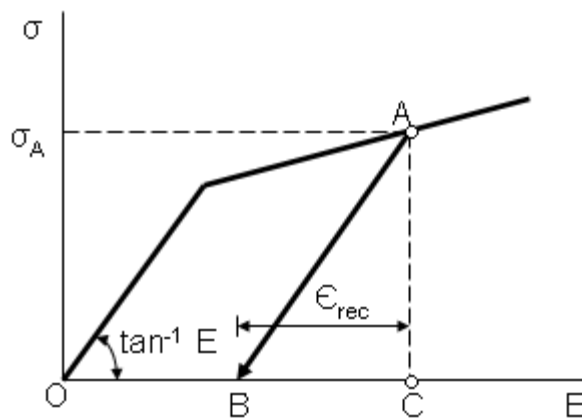

Fig 9 Stress-strain diagram

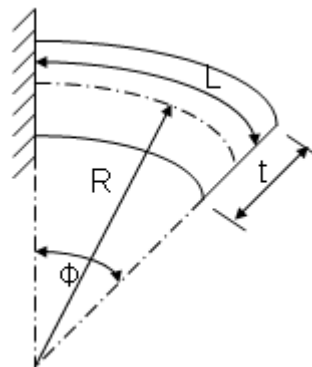

Fig 10 Geometric details

International Journal of Innovative Research in Science, Engineering and Technology

(An ISO 3297: 2007 Certified Organization)

Vol. 5, Special Issue 8, May 2016

So, the amount of bending strain recovered is given by the elastic bending strain resulting from a bending moment M which is removed when the operation is over. The elastic strain of a beam due to a bending moment M results in an included angle Φ (as shown in fig 10) such that (when the curvature effect is neglected)

$$M/I = E/R = E\Phi / L,$$

Where I and R are the second moment of area of the beam cross-section and the radius of curvature, respectively, and L is the length of the neutral plane. Thus

$$\Phi = ML / (EI)$$

Which is nothing but the amount of springback required.

The formulation for the springback model can be done both by numerical and analytical method. Various works are carried out in this area for sheet metal forming. A notable work is done by Mei Zhan et al (2006).

Mei Zhan et al (2006) in their paper proposed a numerical-analytic method for springback angle prediction of the process.

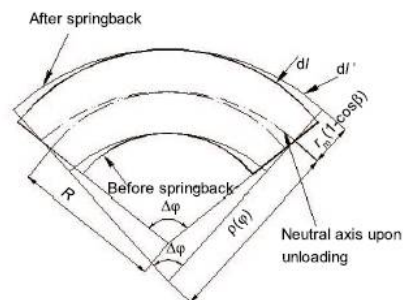

Fig. 11 Springback model of bending portion

The method is based on springback angle model derived using analytic method and simulation results from three-dimensional (3D) rigid-plastic finite element method (FEM). The method is validated through comparison with experimental results. The features of the method are as follows: (1) The method is high in efficiency because it combines advantages of rigid-plastic FEM and analytic method. (2) The method is satisfactory in accuracy, since the field variables used in the model is resulting from 3D rigid-plastic FEM solution, and the effects both of axial force and strain neutral axis shift have been included. (3) Research on multi-factor effects can be carried out using the method due to its advantage inheriting from rigid-plastic FEM.

The various factors that affect springback are

- Mechanical properties
- Bend radius
- Speed at which bending occur
- Grain direction of the cylinder to bend
- Lubrication
- Thickness of the wall

These factors play a vital role in the springback analysis. Various works have been carried out for the study of these properties in bending.

Yang Jialing, Reid (1997), in their paper proposed an approximate method for the evaluation of the plastic hardening softening behavior i.e., the relationship between the bending moment and the curvature of pipes subjected to pure bending. Theoretical predictions from the simple analytical expressions suggested in this paper give results of the critical curvature, the critical strain, the maximum bending moment and the maximum change of the pipe diameter, which are in good agreement with the experimental ones during uniform ovalization. Based on observations of four-point bending

International Journal of Innovative Research in Science, Engineering and Technology

(An ISO 3297: 2007 Certified Organization)

Vol. 5, Special Issue 8, May 2016

tests, a local collapse model following the end of uniform ovalization stage is proposed to describe the softening behavior of purely bended pipes.

Lakirev et al (1997), in their paper New Technologies of cold bending, proposes some methods for reducing bending stresses. They have listed various methods for reducing bending errors. But they have specifically concentrated on reducing bending stresses. Bending stresses can be reduced by heating and creating complexly stressed state. Among this two the authors prefer the latter since heating requires more power and also complex and costly equipments are required. Creating complexly stressed state follows Tresca-saint venant's plasticity principle. This is achieved without vibration by creating internal hydraulic pressure, expansion of pipe diameter by pushing through horn shaped core and expansion of pipe by stretching. Using this experiments were conducted and bending moment was found to be diminishing. The desired efficiency is also obtained.

IV. CONCLUSIONS

The springback problem is mainly affected by mechanical properties, bend radius, grain distortion, and lubrication and so on. Out of these geometrical parameters and material properties play a vital role in springback as we see from the literature review. So required materials can be chosen and bending of tubes using this materials can be analyzed and a process control chart can be formed. Experimental set up for tube bending can be done using methods studied in literature review. An artificial neural network model of the problem can be created using software EasyNN-plus software. The parameters which affect springback can be taken as input parameters and the angle of springback can be taken as output parameter. Neurons can be formed between this with hidden layer in between. Initial set of readings can be taken from the experimental method and it can be given as input to the ANN for learning part, and then generalization can be done to obtain the required result.

REFERENCES

- [1] Arunvenkatesh.T, PROF Deivasigamani.R. (2006) "Analysis of springback in deep drawing Process", MOSIM.
- [2] Inamdarl.M, Dattel.P.P, Narasimhan.K, Maiti1.S.K and Singh.U.P. (2000) "Development of an Artificial Neural Network to Predict Springback in Air Vee Bending", International Journal for Advanced Manufacturing Technology.
- [3] Jun Zeng, Zhaoheng Liu, Henri Champlaud. (2 0 0 8) "FEM dynamic simulation and analysis of the roll-bending process for forming a conical tube", journal of materials processing technology 1 9 8 pp 330–343.
- [4] Kunal Indravadan patel. (2006) "Evaluation of springback prediction capability using uniform pure bending". Thesis for Bachelor of engineering.
- [5] Lakirev. S.G., Ya.M.Khii, Kevich, A.V.Kozlov, and A.V. Bobylev. (1997) "New technology of cold bending of pipes, chemical and petroleum engineering, vol. 33. no 6.
- [6] Lin.S.Y. (1998) "Spring Back Phenomenon Exhibited in the Process of Hollow Cylinder Upsetting", International Journal for Advanced Manufacturing Technology.
- [7] Lucian lăzărescu, Gheorghe achimaș, Diana ognean and Florica groze. (2005) "Prediction of quality parameters in the tube bending process using artificial neural networks", Universitatea Tehnică "Gh. Asachi"
- [8] Luk'yanov.V.P. and Zubkov A.I. (1968) "Investigation of tube bending on a tube-bending machine with mandrel", UDC 621.774.63006
- [9] Mei zhan, He yangy and Liang huang. (2006) "A numerical-analytic method for quickly predicting springback of numerical control bending of thin-walled tube", Journal of material science and technology, vol.22 no.5.
- [10] Mikhail sorine (2007) "Formability of advanced high strength steel tubes in tube bending and hydroforming". Thesis for Master of science.
- [11] Rohit agarwal (2004) "Tube bending with axial pull and internal pressure". Thesis for master of science.
- [12] Song yuquan, Guan zhiping, Nie yuqin & Guan xiaofang. (2006) "The analysis of the bending stiffness and intensity of cylindrical tubes," science in china series
- [13] Strano M. (2005) "Automatic tooling design for rotary draw bending of tubes", International journal of advanced manufacturing technology.
- [14] Xi wang, Jian cao (2001) "Wrinkling limit in tube bending", vol. 123
- [15] Xie daji, Feng shengbo, Zhao rufa, Hu degui, Gu shouren, Wang zengmei.(1998) "New development of the magnetic method for residual stress testing", Acta mechanica solida sinica, vol. 11, no. 2.
- [16] Yang Jialing, S.R.Reid. (1997) "Approximate estimation of hardening-softening behaviour of circular pipes subjected to pure bending", Acta mechanica sinica (english series),vol.13, no.3.