

International Journal of Innovative Research in Science, Engineering and Technology

(An ISO 3297: 2007 Certified Organization)

Vol. 6, Special Issue 9, May 2017

MATLAB based Modeling and Simulation of Various Power Quality Disturbances in a Distributed Power Network

Harshit Srivastava*, Stuti Shukla Datta*

*Department of Electrical & Electronics Engineering, Amity University, Lucknow, India

ABSTRACT: The aim of this paper is to study and model the various causes which are responsible for the emergence of power quality disturbances in a distributed power network. Today emerging electric power network can be conceived as a medium which facilitates exchange of energy among its customers where customers of the network are not solely the end users of electricity. Since the exchange of energy takes place through voltages and currents, these parameters should strictly be observed the constraints on their deviations from the nominal value. New advancements like integration of distributed generation to the network system and advancement in converter based loads have given rise to several disturbances that cause interference in smooth exchange of energy among the network users. Moreover, electric power quality has become an important issue in the deregulated power systems. It is one of the differentiating factors among competitive suppliers. Thus there is a need to address the causes that are behind these disturbances. In this paper MATLAB based modeling and simulation of various Power quality disturbances is carried out. Four commonly encountered disturbances namely Sag, Swell, harmonic, Transient are studied and modeled.

KEYWORDS: Power Quality, Modeling, Simulation, PQ events, Harmonics, Sag, Swell, Transient

I. INTRODUCTION

Due to the proliferation of semiconductor based loads, reliability of the supply has become major focus area for the power engineers today. Not only they are highly sensitive to disturbances but also sometimes are the causes of these disturbances. Most of the study and literatures are dedicated towards finding the suitable techniques that can easily characterize their events [1]. Many signal processing techniques are being employed for this purpose. Among these Fourier transform [3] is commonly used in practice to extract harmonic information present in a voltage or current signal. However, many disturbances are non stationary and may occur for a short duration of time like transient or spike. Thus more sophisticated and robust methodology should be employed. Researches have come up with promising results with Short time Fourier Transform and Wavelet Transform. However STFT suffers from fixed window problem and in wavelet information extraction is an issue due to overlapping levels. However, researches are coming up with many robust and other efficient techniques for power quality event characterization [2-6]. For power quality analysis, it is imperative to have disturbed or distorted signal database. However, due to the non availability or limited availability of the data, it becomes difficult to study any efficient techniques. Thus this paper studies the commonly encountered power quality events in the distribution network. The paper also discusses the modeling and simulation of various power quality events using MATLAB/ Simulink platform. The events such voltage sag, voltage swell, harmonics and transients are considered in this work. The paper gives the models developed for such events along with their simulated results. The paper is organized into five section. Section one discusses the need for power quality event characterization and techniques employed in the researches for the same. Section two discusses the events to be modeled in discusses and their probable causes. Section three discusses the modeling and simulation of various power quality events. Section four discusses the results and in Section five conclusion of the paper is given.

II. POWER QUALITY EVENTS AND CAUSES

Electric Power Network is a huge interconnected system of several loads, transmission feeders, and generator units. Any disturbance or violation in the current or voltage levels affects the entire connected system. Moreover, new

International Journal of Innovative Research in Science, Engineering and Technology

(An ISO 3297: 2007 Certified Organization)

Vol. 6, Special Issue 9, May 2017

advancements like integration of distributed generation to the network system and advancement in converter based loads have given rise to several disturbances that cause interference in smooth exchange of energy among the network users. Moreover, electric power quality has become an important issue in the deregulated power systems. It is one of the differentiating factors among competitive suppliers. Thus power engineers are more focus towards ensuring the overall health of the system.

There are several events that occur in the system which affects the system reliability. Out of these some commonly encountered events are voltage sag, voltage swell, harmonics and transient. For the convenience of the reader, brief descriptions of the events are given here [7].

Voltage Sag: A decrease of the normal voltage level between 10% and 90% of the nominal rms voltage at the power frequency, for durations of 0 to 5 cycle or 1 minute is known as voltage sag. The major causes are faults on the transmission or distribution network, faults in consumer's installation and connection of heavy loads and start-up of large motors. The consequences of voltage sag are the malfunction of information technology equipment, namely microprocessor-based control systems (PCs, PLCs) that may lead to a process stoppage, tripping of contactors and electromechanical relays, disconnection and loss of efficiency in electric rotating machines.

Voltage Swell: The momentary increase of the voltage, at the power frequency, outside the normal tolerances, with duration of more than one cycle and typically less than a few seconds, is known as voltage swell. The major causes are start/stop of heavy loads, badly dimensioned power sources, badly regulated transformers (mainly during off-peak hours). Voltage swell leads to data loss, flickering of lighting and screens, stoppage or damage of sensitive equipment, if the voltage values are too high.

Harmonic Distortion: During harmonic distortion, voltage or current waveforms assume non-sinusoidal shape. The waveform corresponds to the sum of different sine-waves with different magnitude and phase, having frequencies that are multiples of power-system frequency. There are two causes of harmonic distortion namely: *Classic sources:* electric machines working above the knee of the magnetization curve (magnetic saturation), arc furnaces, welding machines, rectifiers, and DC brush motors. *Modern sources:* all non-linear loads, such as power electronics equipment including ASDs, switched mode power supplies, data processing equipment, high efficiency lighting. Harmonic Distortion causes increased probability in occurrence of resonance, neutral overload in 3-phase systems, overheating of all cables and equipment, loss of efficiency in electric machines, electromagnetic interference with communication systems, errors in measures when using average reading meters and nuisance tripping of thermal protections.

Transient: Transient can be defined as a very brief (<0.5 cycle) fluctuation in the magnitude of voltage. The primary causes of transients are switching events and lightning, either direct strike or induced current. Depending on their severity (magnitude and/or energy), these events may cause equipment damage.

MATLAB/Simulink is one of the powerful simulation tools for modelling and analysing the real-time systems in an efficient manner. In this paper, a comprehensive model of real-time power distribution system is created by using SimPower System toolboxes. Next section gives the modelling and simulation of various power quality events.

III. MODELLING AND SIMULATION OF PQ EVENTS

This section deals with electrical system models for obtaining disturbance waveforms.

Out of many scenarios only one scenario for each class is given here.

Voltage Sag: Fig. 1 depicts the simulation of voltage sag. Here a three phase fault is created at the end of pi section line and voltage waveforms at supply side are observed. Simulated waveform is depicted in Fig. 2

Voltage Swell: Fig. 3 depicts the simulation of voltage swell. Swell is created by removing a heavy load from the system for few second. Simulated waveform is depicted in Fig. 4

Harmonic Distortions: Fig. 5 depicts the simulation of harmonics. Here two non linear loads (diode) are incorporated in the system. Simulated waveform is depicted in Fig. 6

Transient: Fig. 7 depicts the simulation of transient. Here transients are simulated by switching on heavy capacitor bank on the supply side. Simulated waveform is depicted in Fig. 8

International Journal of Innovative Research in Science, Engineering and Technology

(An ISO 3297: 2007 Certified Organization)

Vol. 6, Special Issue 9, May 2017

IV. RESULTS AND DISCUSSION

In this work the Simulink models for various events that are responsible for voltage and current distortions are developed. Here the sampling time for all the events is taken as .0003125sec. Here all the models are simulated at discrete mode. Voltage sag due to fault is successfully simulated. Voltage swell due to temporary removal of heavy load is simulated successfully. Harmonics are simulated using nonlinear diode loads and Transient is simulated by switching on heavy capacitor bank.

V. CONCLUSION

The paper studies the causes of various power quality events and develops electrical system models for these disturbances. To ensure reliable supply, to prevent malfunctioning of protection system and to increase life of electrical equipment, it is imperative that power quality assessment is properly and timely performed. Efficiency of several techniques is evaluated on the databases having various voltages and current data values. However, due to non availability of the practical data it becomes imperative to create one's own database for the assessment of techniques. Thus this paper aims to develop electrical system models for various events which further can be employed in analysing suitable power quality assessment technique.

REFERENCES

- [1] F. Jurado, N. Acero, and B. Ogayar, "Application of signal processing tools for power quality analysis," in *Proc. of Canadian Conf. Electrical and Computer Engineering*, May 2002, vol. 1, pp. 82–87.
- [2] O. Poisson, P. Rioual, and M. Meunier, "Detection and measurement of power quality disturbances using wavelet transform," *IEEE Trans. Power Del.*, vol. 15, no. 3, pp. 1039–1044, Jul. 2000.
- [3] S. Santoso, W. M. Grady, E. J. Powers, J. Lamoree, and S. C. Bhatt, "Characterization of distribution power quality events with Fourier and wavelet transforms," *IEEE Trans. Power Del.*, vol. 15, no. 1, pp. 247–254, Jan. 2000.
- [4] A. M. Gaouda, S. H. Kanoun, M. M. A. Salama, and A. Y. Chikhani, "Pattern recognition applications for power system disturbance classification," *IEEE Trans. Power Del.*, vol. 17, no. 3, pp. 677–683, Jul. 2002.
- [5] Z.-L. Gaing, "Wavelet-based neural network for power disturbance recognition and classification," *IEEE Trans. Power Del.*, vol. 19, no. 4, pp. 1560–1568.
- [6] S. Santoso, E. J. Powers, W. M. Grady, and A. C. Parsons, "Power quality disturbance waveform recognition using wavelet-based neural classifier- part I: Theoretical foundation," *IEEE Trans. Power Del.*, vol. 15, no. 1, pp. 222–228, Oct. 2004.
- [7] M.H.J. Bollen, "What is Power Quality", *Electric Power Systems Research*, vol.66, pp.5-14, July 2003.

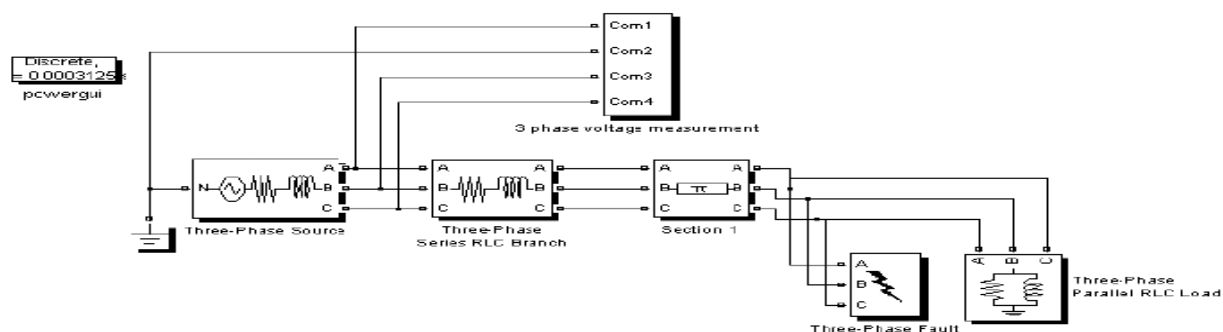

Fig. 1 Simulation of voltage sag

International Journal of Innovative Research in Science, Engineering and Technology

(An ISO 3297: 2007 Certified Organization)

Vol. 6, Special Issue 9, May 2017

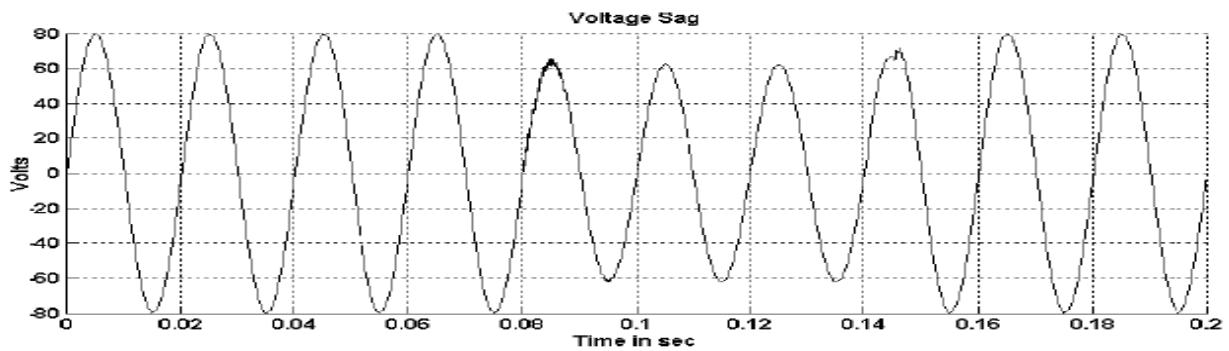

Fig. 2 Waveform depicting voltage sag

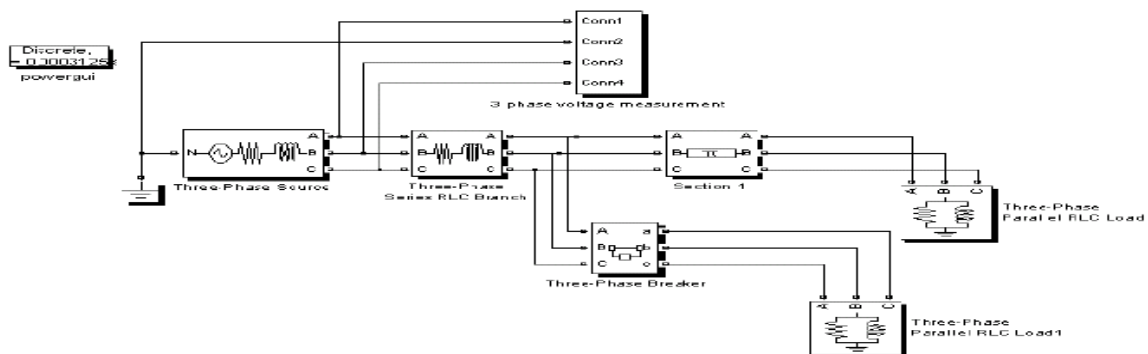

Fig. 3 Simulation of voltage swell

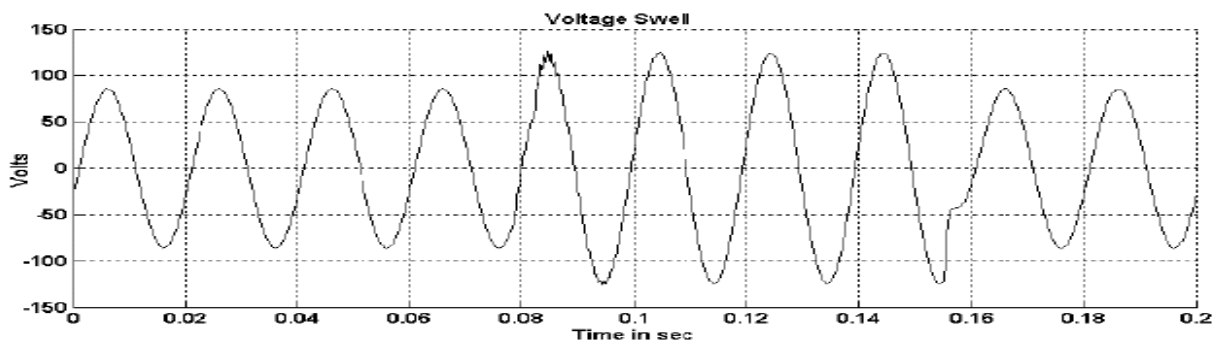

Fig. 4 Waveform depicting voltage swell

International Journal of Innovative Research in Science, Engineering and Technology

(An ISO 3297: 2007 Certified Organization)

Vol. 6, Special Issue 9, May 2017

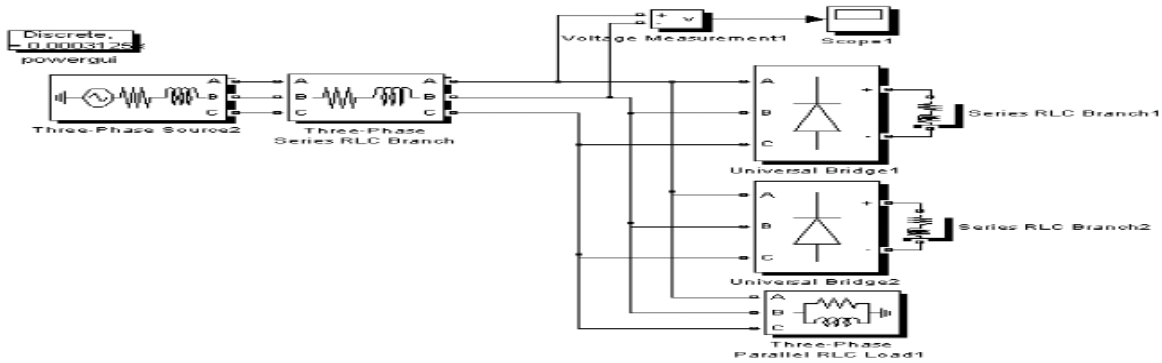

Fig. 5 Simulation of harmonics

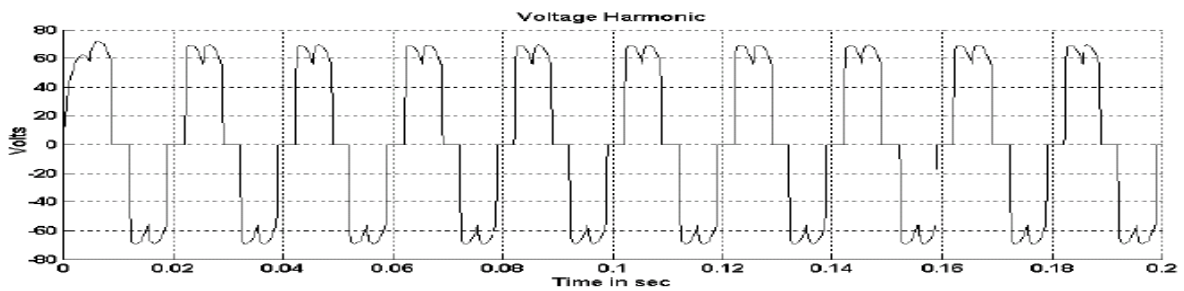

Fig. 6 Waveform depicting harmonics

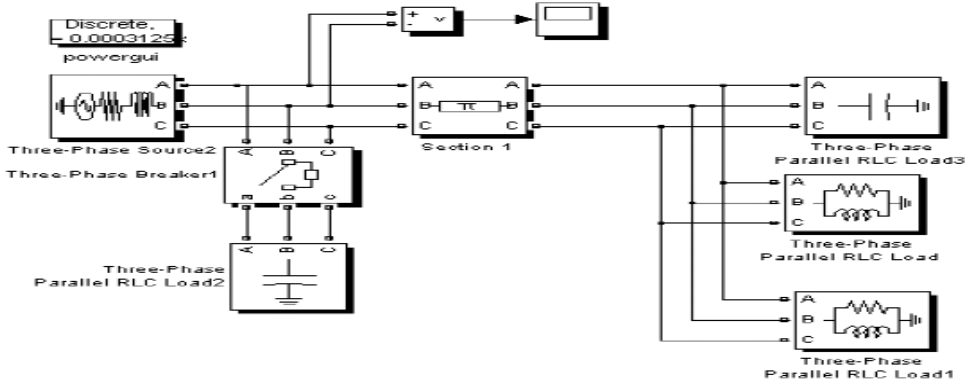

Fig. 7 Simulation of transient

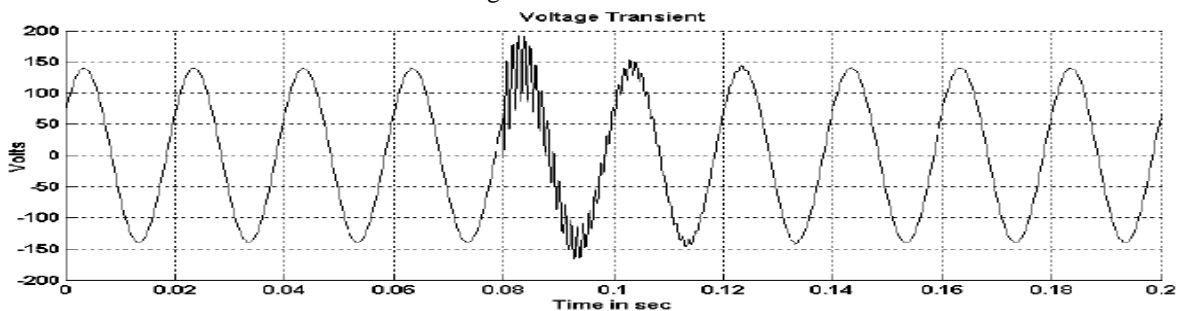

Fig. 8 Waveform depicting transient