

WSN based Smart Grid Applications: Study on Link Reliability and Node Lifetime Evaluations in Power Distribution Systems

Vaibav Sharma, Satish Kumar

Amity School of Engineering & Technology, Amity University Uttar Pradesh, Lucknow Campus, India

ABSTRACT: Recent advances in embedded systems and wireless sensor networks (WSNs) have made it possible to realize low-cost monitoring and automation systems for smart grids. This paper presents opportunities and design challenges of WSNs for smart grid applications. In addition some WSN standards and communication protocols have also been discussed. Existing power distribution networks suffer from the lack of effective fault diagnostics, monitoring, automation, and communications. Importantly, node lifetime and link reliability in wireless sensor networking for smart grid applications have been evaluated in electric power system environments.

KEYWORDS: wireless sensor network, analytical modelling, monitoring, efficiency, reliability.

I. INTRODUCTION

Smart grid has the potential to provide reliable, efficient and safe energy automation service. It would involve two-way communication. Employing the capabilities of wireless sensor network, it can record and analyze data related to give an idea of the typical power usage, delivery and utilization. It finds wide application in wireless automatic meter reading (WAMR) system. Smart grids are modern electric power grid infrastructures, which provide smooth incorporation of alternative and renewable energy sources through modern communication and sensing technologies and automated control [3, 4].

The potential benefits of smart grids are numerous and they can be outlined as follows [5]:

- (i) increased energy consumption information available to consumers,
- (ii) improved physical and operational security and resilience against attacks or disasters,
- (iii) increased energy efficiency,
- (iv) improved reliability and safety,
- (v) the integration of a higher percentage of renewable energy sources,
- (vi) easy integration of plug-in electric vehicles.

Different from the existing power grids, in smart grid, online and reliable information is the main factor for the reliable delivery of energy from the generation units to the users. Generally, a smart grid network consists of the following three segments.

- (1) *Home area networks (HANs)* connect smart meters with on premise appliances, distributed renewable sources, and electrical vehicles.
- (2) *Neighborhood area networks (NANs)* carry information between customer premises and aggregation points.
- (3) *Wide area networks (WANs)* serve as the backbone for communication between the utility data center and aggregation points.

Recent advances in embedded systems and wireless sensor networking made it possible to execute low-cost monitoring and diagnostic systems for smart grids [7]. These systems receive information from wireless sensor nodes, which monitor crucial smart grid equipment and are used to monitor and respond to the changing conditions in a proactive

International Journal of Innovative Research in Science, Engineering and Technology

(An ISO 3297: 2007 Certified Organization)

Vol. 6, Special Issue 9, May 2017

manner. Hence, WSNs are seen as a promising and complementary technology for various smart grid applications [1, 8, 9]. Some of the existing and envisaged applications of WSNs in smart grids include load management and control, wireless automatic meter reading (WAMR), equipment fault diagnostics, remote monitoring, electric fault detection, and distribution automation. However, harsh and complex propagation environments, very common in electric power distribution networks, cause wireless communication challenges in terms of reliability and delay and require specific attention during installation in smart grid applications. Also, guaranteeing a specific quality of service (QoS) is a challenging issue in WSNs due to the inherent properties of WSNs, such as unstable topology, unpredictable nature of wireless links, and resource constraints [10]. In addition, in bandwidth-limited and battery operated WSNs, there is a tradeoff between node lifetime, which requires sensor nodes to follow sleeping schedules with longer periods, and link reliability, which requires sensor nodes to be active in most of their operations in smart grid. Therefore, the relationship between node lifetime and link reliability in smart grid environments needs to be surveyed.

II. WSN-BASED SMART GRID APPLICATIONS

Generally, WSN-based smart grid applications are divided into three groups: consumer side, transmission and distribution (T&D) side, and generation side WSN-based smart grid applications [17].

(i) *Consumer Side WSN-Based Smart Grid Applications*: Consumer side WSN-based smart grid applications have a direct relationship with different types of customers. Consumer side applications include advanced metering infrastructure, residential energy management, automated panels management, building automation, demand-side load management, process control monitoring, and equipment management and control monitoring.

(ii) *Transmission and Distribution (T&D) Side WSN Based Smart Grid Applications*: T&D side covers overhead powerlines, underground powerlines, and substations, and the applications designed for this side play a key role in smart grid, since these systems are responsible for successful power transmission. Some of the transmission and distribution side WSN based smart grid applications are overhead transmission line monitoring, outage detection, conductor temperature rating systems, underground cable system monitoring, fault diagnostics, overhead and underground fault circuit indicators, cable, conductor and lattice theft, fault detection, and location.

(iii) *Generation Side WSN-Based Smart Grid Applications*: These applications are generally based on monitoring task. Some of them are real-time generation monitoring, remote monitoring of wind farms, remote monitoring of solar farms, power quality monitoring, and distributed generation.

III. DESIGN CHALLENGES OF WSNs IN SMART GRIDS

The major technical challenges for realization of WSN-based smart grid applications can be outlined as follows.

(1) **Resource Limitations of Sensor Nodes**. The design and implementation of a WSN is constrained by the hardware resources of sensor nodes due to limited physical size, such as energy, memory, and processing.

(2) **Harsh Environmental Conditions and Dynamic Topologies**. In power distribution environments, the connectivity and topology of the network may vary due to varying wireless link characteristics and node failures[1].In addition, sensor nodes may be subject to different environmental conditions which may cause sensor nodes to malfunction[7,19].

(3) **QoS Requirements of Smart Grid Applications**. Different QoS requirements and specifications in terms of reliability, throughput, and latency are required for different types of existing and envisaged smart grid applications as seen in Table 1. (4) **Packet Errors and Variable-Link Capacity**. In electric power system environments, due to noisy environment and obstructions, the bandwidth of wireless links depend on the interference level perceived at receivers, and high bit error rates are observed in communication[1].Therefore, it is very hard to meet QoS requirements in smart grid applications due to the varying characteristics of wireless links[1,19,20].

(5) **Security**. Security is an essential feature in the design of WSN-based smart grid applications in order to provide safe communication by preventing intrusion and denial of service (DoS) attacks [20].

International Journal of Innovative Research in Science, Engineering and Technology

(An ISO 3297: 2007 Certified Organization)

Vol. 6, Special Issue 9, May 2017

IV. LINK RELIABILITY ANALYSIS

In this section, the results of our reliability analysis are given for different smart grid environments, including indoor power control room, outdoor 500k V substation, and underground network transformer vault.

Experimentally determined log normal channel parameters for different power system environments in non-line of sight (NLOS) are given in Table 2 [1]. In this case study, we have modelled the wireless channel by the use of a log-normal shadowing path-loss model through a combination of empirical measurements and analytical techniques. Experimental studies show that modelling the wireless channel using a log-normal shadowing path loss model provides more accurate multipath channel models compared to the Nakagami and Rayleigh models [1, 12].

In this study, packet reception rate (PRR), the ratio between the number of successful packets and the total number of transmitted packets, is used to evaluate the reliability of wireless links in three different smart grid environments, such as outdoor substation, underground transformer vault, and indoor main power room. For this analysis, an evaluation environment has been developed using ANRG [13]. Experimentally determined log-normal wireless channel parameters for different power system environments are given in Table 2. Using this channel model, we have obtained PRR versus distance in a network, including multiple sensor nodes located in different locations.

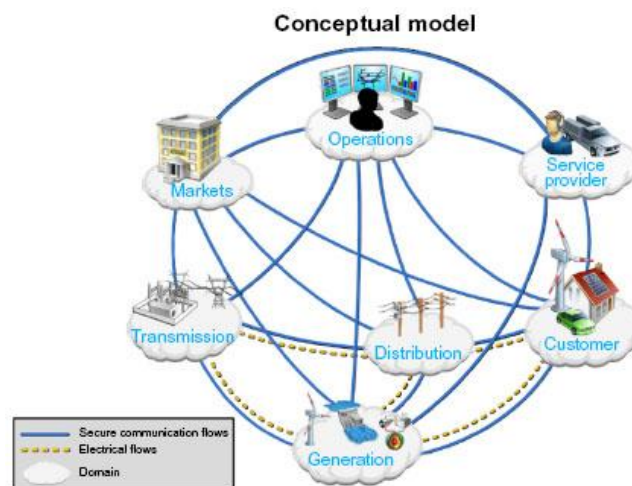

Smart Grid Framework^[4]

V. POWER UTILIZATION

Wireless sensor network can be used in home area networks (HANs). As mentioned, ZigBee is a suitable choice for HANs. It provides the reliable wide area coverage and predictable latencies that are expected for smart grid. A typical application of WSN for smart grid is wireless automatic meter reading (WAMR) systems, which can determine real-time energy consumption of the customers as customers can download their archives and take it to meter reading through a mobile device. WAMR can also improve business performance and technical reliability for power utility operations, as utility companies can identify more valuable customers by comparing the data between the distributed generation sources and overall power consumption [4].

VI. POWER DELIVERY

Wireless sensor networks can also be used in electric power system operations and substation automation. For example, sensors could be installed to monitor the delivery systems and power use in the system, and sensors can be further classified according to their location. Substations could also be monitored as circuit currents, power usage and station apparatus are checked here [9]. WSNs can also provide a feasible and cost-effective sensing and communication

International Journal of Innovative Research in Science, Engineering and Technology

(An ISO 3297: 2007 Certified Organization)

Vol. 6, Special Issue 9, May 2017

solution for remote system monitoring systems. The conditions of different smart grid operation process, (e.g., generation units, transformers, transmission lines, and motors), can be monitored by the large-scale deployment of smart sensor nodes in a remote, and these nodes can be installed on the critical equipment of smart grid. Therefore, a single system contingency in the power grid can be detected and isolated before it causes cascading effects [10]. Besides, measuring voltages and currents associated with transformers, circuit breakers, and switches in a substation or a distribution station, power quality sensors, transformer temperature sensors, and breaker position indicators may also be monitored [9].

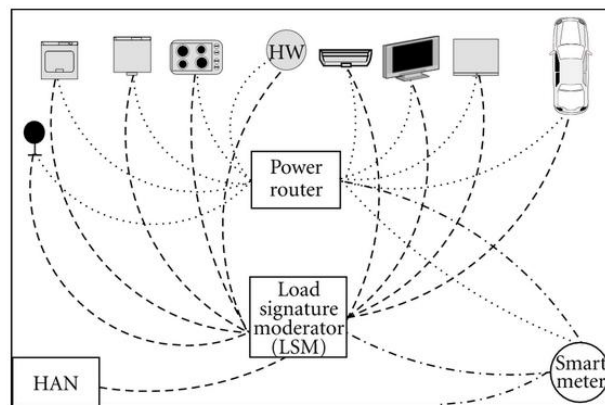

Home Area Networks (HANs) example^[2]

VII. POWER GENERATION

A bulk generation plant may have several generation units, and several hundred actuators may control fuel, air, and water flows to optimize heat rate (efficiency of the generator) control emissions, and make adjustments to generator output within each unit [9]. Wireless sensors could be installed to assess the generation systems in power plants, and WirelessHART or ISA100.11a could be used to deploy sensors here. Sensors that use IEEE 802.15.4-based radio transceivers can work for several years in harsh environments without requiring any external power (e.g., WirelessHART can route around not only single but also multiple node failures) [9]. Besides, sensors can be easily relocated and supplementary sensors can be used within a short notice. Therefore, each generation unit may measure parameters such as steam temperature and air, water, or fuel flow rates based on these sensors.

VIII. CONCLUSIONS

This paper presents major opportunities and design challenges of WSNs for smart grid applications. WSN-based smart grid applications are introduced, and main WSN standards and communication protocols have been discussed for smart grid applications. Importantly, power generation, distribution and delivery in wireless sensor networking for smart grid applications have been evaluated through case studies. Overall, this paper explains research challenges resulting from inherent properties of WSNs and smart grid propagation environments. In addition, our experimental studies show that network designers planning to use WSNs for smart grid applications need to take into consideration, important sensor node parameters including transmission power, range, and channel parameters. Future work includes the development of cross layer communication protocols to check link-quality variations in smart grid environments, QoS provisioning, and coordinated network management for different application types of smart grids. In addition, in order to prove the advantages of energy harvesting techniques for WSN-based smart grid applications, a set of experiments will be performed and statistical evaluations will be done. A group of field tests will be conducted in a main power room and near a substation. In the same locations, another group of field tests will be performed to examine the relation between link reliability and node lifetime.

International Journal of Innovative Research in Science, Engineering and Technology

(An ISO 3297: 2007 Certified Organization)

Vol. 6, Special Issue 9, May 2017

REFERENCES

- [1] V. C. Gungor, L. Bin, and G. P. Hancke, "Opportunities and challenges of wireless sensor networks in smart grid," IEEE Transactions on Industrial Electronics, vol. 57, no. 10, pp. 3557–3564, 2010.
- [2] T. Sauter and M. Lobashov, "End-to-end communication architecture for smart grids," IEEE Transactions on Industrial Electronics, vol. 58, no. 4, pp. 1218–1228, 2011.
- [3] A. R. Metke and R. L. Ekl, "Security technology for smart grid networks," IEEE Transactions on Smart Grid, vol. 1, no. 1, pp. 99–107, 2010. [2] P. Sakarindr and N. Ansari, "Security services in group communications over wireless infrastructure mobile ad hoc, and wireless sensor networks," IEEE Wireless Communications, vol. 14, no. 5, pp. 8–20, 2007.
- [4] S. S. S. R. Depuru, L. Wang, and V. Devabhaktuni, "Smart meters for power grid: challenges, issues, advantages and status," Renewable and Sustainable Energy Reviews, vol. 15, no. 6, pp. 2736–2742, 2011.
- [5] U.S. NIST, "NIST framework and roadmap for smart grid interoperability standards, release 1. 0," NIST Special Publication 1108, 2010, <http://www.nist.gov/publicaffairs/releases/upload/smartgridinteroperabilityfinal.pdf>.
- [6] A draft version of this publication by NIST, <http://www.nist.gov/publicaffairs/releases/upload/smartgrid092409fr.pdf>.
- [7] G. Kalogridis, C. Efthymiou, S.Z. Denic, T. A. Lewis, and R. Cepeda, "Privacy for smart meters: towards undetectable appliance load signatures," in Proceedings of the 1st IEEE International Conference on Smart Grid Communications, pp. 232–237, Gaithersburg, Md, USA, October 2010.
- [8] J. D. Howard and T. A. Longstaff, "A common language for computer security incidents," Sandia National Laboratories, Sandia Representative, SAND98-8867, 1998.
- [9] B. A. Akyol, H. Kirkham, S. L. Clements, and M. D. Hadley, "A survey of wireless communications for the electric power system," U.S. Department of Energy, 2010.
- [10] V. C. Gungor, B. Lu, and G. P. Hancke, "Opportunities and challenges of wireless sensor networks in smart grid," IEEE Transactions on Industrial Electronics, vol. 57, no. 10,
- [11] V. Raghunathan, A. Kansal, J. Hsu, J. Friedman, and M. Srivastava, "Design considerations for solar energy harvesting wireless embedded systems," in Proceedings of the 4th International Symposium on Information Processing in Sensor Networks (IPSN'05), pp. 457–462, April 2005.
- [12] Z. G. Wan, Y. K. Tan, and C. Yuen, "Review on energy harvesting and energy management for sustainable wireless sensor networks,"
- [13] B. H. Calhoun, D. C. Daly, N. Verma et al., "Design considerations for ultra-low energy wireless micro sensor nodes," IEEE Transactions on Computers, vol. 54, no. 6, pp. 727–740, 2005.
- [14] R. J. M. Vullers, R. V. Schaijk, H. J. Visser, J. Penders, and C. V. Hoof, "Energy harvesting for autonomous wireless sensor networks," IEEE Solid-State Circuits Magazine, vol. 2, no. 2, pp. 29–38, 2010.
- [15] Y. K. Tan and S. K. Panda, "Self-autonomous wireless sensor nodes with wind energy harvesting for remote sensing of wind driven wildfire spread," and Measurement, vol. 60, no. 4, pp. 1367–1377, 2011.
- [16] B. E. Logan, B. Hamelers, R. Rozendal et al., "Microbial fuel cells: methodology and technology," Environmental Science and Technology, vol. 40, no. 17, pp. 5181–5192, 2006.
- [17] V. C. Gungor, D. Sahin, T. Kocaketal., "A survey on smart grid potential applications and communication requirements," IEEE Transactions on Industrial Informatics, vol. 9, no. 1, pp. 28–42, 2013.
- [18] Alcatel-Lucent, "Smart choices for the smart grid," White Paper, Alcatel-Lucent, Murray Hill, NJ, USA, 2010.
- [19] V. C. Gungor and G. Hancke, "Industrial wireless sensor networks: challenges, design principles, and technical approaches," IEEE Transactions on Industrial Electronics, vol. 56
- [20] S. Sudevalayam and P. Kulkarni, "Energy harvesting sensor nodes: survey and implications," IEEE Communications Surveys & Tutorials, vol. 13, no. 3, pp. 443–461, 2