

International Journal of Innovative Research in Science, Engineering and Technology

(A High Impact Factor, Monthly, Peer Reviewed Journal)

Visit: www.ijirset.com

Vol. 6, Issue 12, December 2017

Cost and Design Analysis of Steel and Bamboo Reinforcement

Swapnil Dange, Smita V. Pataskar

M. E Student, Department of Civil Engineering, D.Y Patil College of Engineering Akurdi Pune, India

Professor, Department of Civil Engineering, D.Y Patil College of Engineering Akurdi Pune, India

ABSTRACT: To study the effect of replacement of steel reinforcement by bamboo reinforcement, designs have been conducted on one way slab of size 3000 x 7000 sq-mm with providing beam of 7000 mm length and 250 x 250 sq-mm. In this paper the designs are done on the basis of shearing and bending. Based on this study of cost vs strength provided results have been discussed in the paper. Housing shortage in Urban India due to the rising unaffordability makes it logical to consider alternative technologies for their application. The intention of the research is, to evolve a design using bamboo as one of the chief structural materials, for a safe and durable house, affordable by the urban poor. In this project we will work on to design manually g+1 residential building by replacing steel reinforcement with bamboo reinforcement. Which should be checked or verified by structural designer then we calculate cost of that building and to show the difference between steel reinforcement building and bamboo reinforcement building as well as 1 life period of structure It is targeted at those Urban Poor living close to bamboo growing regions. The design thus evolved shall clearly indicate the cost reduction, of the superstructure where steel reinforced concrete, is replaced by bamboo reinforced concrete, in key structural elements. A higher cost reduction ratio could help in creating affordable housing markets in most growing cities in India. Proven technologies from all over the world have been examined closely to arrive at the one that would minimize the consumption of steel, which constitutes a large share of the cost of a dwelling unit. This Paper shall project some breakthrough findings on which the overall research has based itself.

KEYWORDS: Bamboo, Flexural Strength, Cost Estimation, Economical.

I. INTRODUCTION

The world timber demand is increasing at a rapid rate but the timber supply is depleting. It's been found through research that bamboo can suitably replace timber and other materials in construction and other works. Industrially treated bamboo has shown great potential for production of composite materials and components which are cost-effective and can be successfully utilized for structural and non-structural applications in construction. Bamboo is one of the oldest traditional building materials used by mankind.

The bamboo culm, or stem, has been made into an extended diversity of products ranging from domestic household products to industrial applications. Bamboo is quite common for bridges, scaffolding and housing, but it is usually used as a temporary exterior structural material. In many overly populated regions of the tropics, certain bamboos supply the one suitable material that is sufficiently cheap and plentiful to meet the extensive need for economical housing.

With the advancement of science and technology and the tight supply of timber, new methods are needed for the processing of bamboo to make it more durable and more usable in terms of building materials. Studies have been carried out on the basic properties and on processing of bamboo into various kinds of composite products. Bamboo has several unique advantages like ability to grow fast with a high yield and also it matures quickly. Additionally bamboo can be grown abundantly and that too at a lower cost which makes it more economical.

International Journal of Innovative Research in Science, Engineering and Technology

(A High Impact Factor, Monthly, Peer Reviewed Journal)

Visit: www.ijirset.com

Vol. 6, Issue 12, December 2017

II. BAMBOO AS CONSTRUCTION MATERIAL

Through research it has been found that some species of bamboo have ultimate tensile strength same as that of mild steel at yield point. Experimentally it has been found that the ultimate tensile strength of some species of bamboo is comparable to that of mild steel and it varies from 140N/mm²- 280N/mm². Bamboo is a versatile material because of its high strength-to-weight ratio, easy workability and availability. Bamboo needs to be chemically treated due to their low natural durability. It can be used as Bamboo Trusses, Bamboo Roofs Skeleton, Bamboo walling/ceiling, Bamboo Doors and Windows, Bamboo Flooring, Reed Boards, Scaffolding. It has also been found that bamboo acts very well in buckling but due to low stresses than compared to steel and due to it not being straight it may not be very good. Further, it has been established that in seismic zones the failure of bamboo is very less as the maximum absorption of the energy is at the joints. Cellulose is the main component present in bamboo which is the main source of mechanical properties of bamboo.

Some specific properties of Bamboo are as given below:

1. Specific gravity - 0.575 to 0.655
2. Average weight - 0.625kg/m
3. Modulus of rupture - 610 to 1600kg/cm²
4. Modulus of Elasticity - 1.5 to 2.0 x10⁵kg/cm²
5. Ultimate compressive stress- 794 to 864kg/cm²
6. Safe working stress in compression - 105kg/cm²

Safe working stress in tension It has also been found that bamboo acts very well in buckling but due to low stresses than compared to steel and due to it not being straight it may not be very good.

Further, it has been established that in seismic zones the failure of bamboo is very less as the maximum absorption of the energy is at the joints. Cellulose is the main component present in bamboo which is the main source of mechanical properties of bamboo.

Some specific properties of Bamboo are as given below:

1. Specific gravity - 0.575 to 0.655
2. Average weight - 0.625kg/m
3. Modulus of rupture - 610 to 1600kg/cm²
4. Modulus of Elasticity - 1.5 to 2.0 x10⁵kg/cm²
5. Ultimate compressive stress- 794 to 864kg/cm²
6. Safe working stress in compression - 105kg/cm²
7. Safe working stress in tension - 160 to 350 kg/cm²
8. Safe working stress in shear- 115 to 180 kg/cm²
9. Bond stress - 5.6kg/cm²

III. SELECTION AND PREPARATION OF BAMBOO SELECTION

The following factors should be considered in the selection of bamboo culms (whole plants) for use as reinforcement in concrete structures:

1. Use only bamboo showing a pronounced brown colour. This will insure that the plant is at least three years old.
2. Select the longest large diameter culms available.
3. Do not use whole culms of green, unseasoned bamboo.

International Journal of Innovative Research in Science, Engineering and Technology

(A High Impact Factor, Monthly, Peer Reviewed Journal)

Visit: www.ijirset.com

Vol. 6, Issue 12, December 2017

4. Avoid bamboo cut in spring or early summer. These culms are generally weaker due to increased fibre moisture content.

Preparation

1. **Sizing-** Splints are generally more desirable than whole culms as reinforcement. Larger culms should be split into splints approximately 3/4 inch wide. Whole culms less than 3/4 inch in diameter can be used without splitting.
3. Splitting the bamboo can be done by separating the base with a sharp knife and then pulling a dulled blade through the stem. The dull blade will force the stem to split open; this is more desirable than cutting the bamboo since splitting will result in continuous fibres and a nearly straight section
4. **Seasoning-** When possible, the bamboo should be cut and allowed to dry and season for three to four weeks before using. The culms must be supported at regular spacing's to reduce warping.
5. **Waterproof Coatings-** When seasoned bamboo, either split or whole is used as reinforcement; it should receive a waterproof coating to reduce swelling when in contact with concrete. Without some type of coating, bamboo will swell before the concrete has developed sufficient strength to prevent cracking and the member may be damaged, especially if more than 4 percent bamboo is used.

IV. CONSTRUCTION PRINCIPLES

In general, techniques used in conventional reinforced concrete construction need not be changed when bamboo is to be used for reinforcement.

Concrete Mix Proportions - The same mix designs can be used as would normally be used with steel reinforced concrete. Concrete slump should be as low as workability will allow. Excess water causes swelling of the bamboo. High early-strength cement is preferred to minimize cracks caused by swelling of bamboo when seasoned bamboo cannot be waterproofed.

Placement of bamboo- Bamboo reinforcement should not be placed less than 1.5 inches from the face of the concrete surface. When using whole culms, the top and bottom of the stems should be alternated in every row and the nodes or collars, should be staggered. This will insure a fairly uniform cross section of the bamboo. Throughout the length of the member, and the wedging effect obtained at the nodes will materially increase the bond between concrete and bamboo. The clear spacing between bamboo rods or splints should not be less than the maximum size aggregate plus 1/4 inch. Reinforcement should be evenly spaced and lashed together on short sticks placed at right angles to the main reinforcement. When more than one layer is required, the layers should also be tied together. Ties should preferably be made with wire in important members. For secondary members, ties can be made with vegetation strips.

Bamboo must be securely tied down before placing the concrete. It should be fixed at regular intervals of 3 to 4 feet to prevent it from floating up in the concrete during placement and vibration. In flexural members continuous, one-half to two-thirds of the bottom longitudinal reinforcement should be bent up near the supports. This is especially recommended in members continuous over several supports.

International Journal of Innovative Research in Science, Engineering and Technology

(A High Impact Factor, Monthly, Peer Reviewed Journal)

Visit: www.ijirset.com

Vol. 6, Issue 12, December 2017

V. TABLES & GRAPHS

a. Properties of bamboo and steel reinforcing bars Bamboo

Whole Culms	
Diameter (in.)	Area (sq. in.)
3/8	0.008
1/2	0.136
5/8	0.239
3/4	0.322
1	0.548
2	1.92

3/4 Inch Wide Splints	
Thickness (in.)	Area (sq. in.)
1/8	0.094
1/4	0.188
3/8	0.282
1/2	0.375
5/8	0.469
3/4	0.563

Steel Reinforcement

Nominal Dimensions - Round Sections		
Bar Designation No.	Nominal Diameter (in.)	Cross Sectional. Area (sq. in.)
2	0.250	0.05
3	0.375	0.11
4	0.500	0.20
5	0.625	0.31
6	0.750	0.44
7	0.875	0.60
8	1.000	0.79
9	1.128	1.00
10	1.270	1.27
11	1.410	1.56

International Journal of Innovative Research in Science, Engineering and Technology

(A High Impact Factor, Monthly, Peer Reviewed Journal)

Visit: www.ijirset.com

Vol. 6, Issue 12, December 2017

Steel Wire

AS&W Wire Gauge Numbers	Diameter (in)	Area (sq. in.)	Weight (lb/ft)
0000	0.3938	0.12180	0.4136
000	0.3625	0.10321	0.3505
00	0.3310	0.086049	0.2922
0	0.3065	0.073782	0.2506
1	0.2830	0.062902	0.2136
2	0.2625	0.054119	0.1838
3	0.2437	0.046645	0.1584
4	0.2253	0.039867	0.1354
5	0.2070	0.033654	0.1143

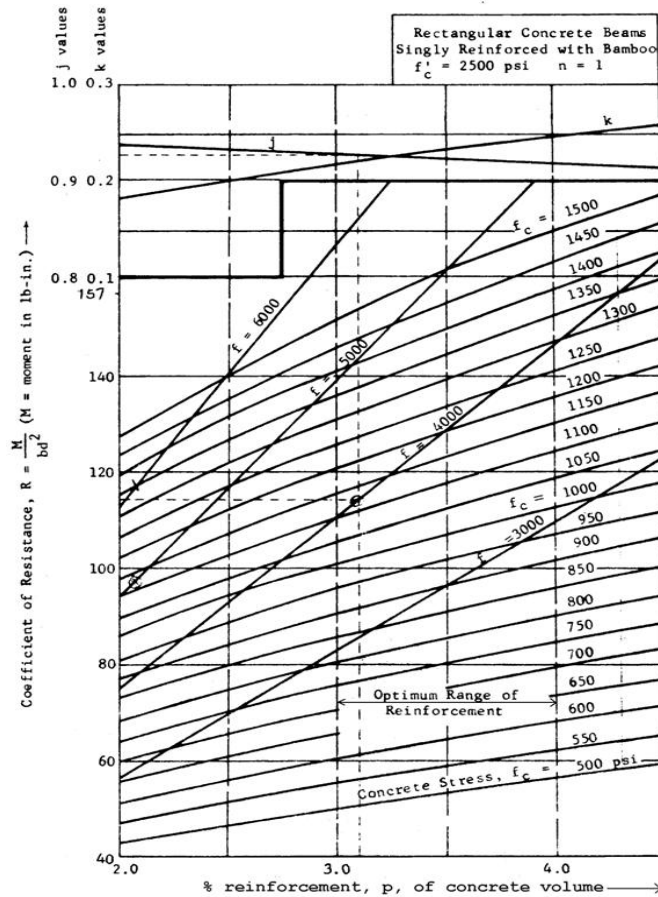

Figure 1- Resistance coefficients for bamboo reinforced concrete beams and their flexural Member.

International Journal of Innovative Research in Science, Engineering and Technology

(A High Impact Factor, Monthly, Peer Reviewed Journal)

Visit: www.ijirset.com

Vol. 6, Issue 12, December 2017

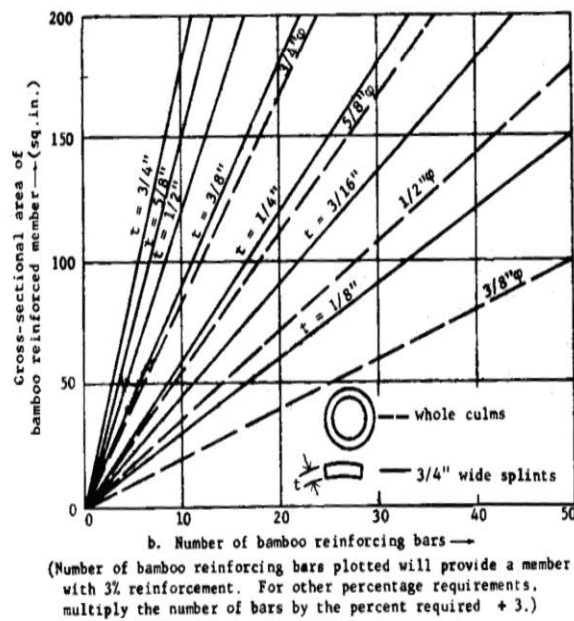
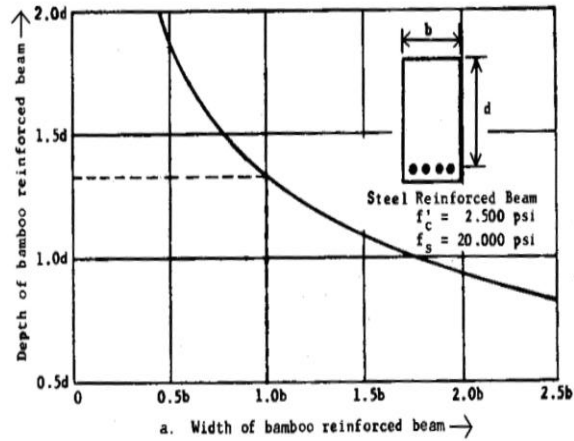

Figure 2- Bamboo substitute beams and reinforcement.

International Journal of Innovative Research in Science, Engineering and Technology

(A High Impact Factor, Monthly, Peer Reviewed Journal)

Visit: www.ijirset.com

Vol. 6, Issue 12, December 2017

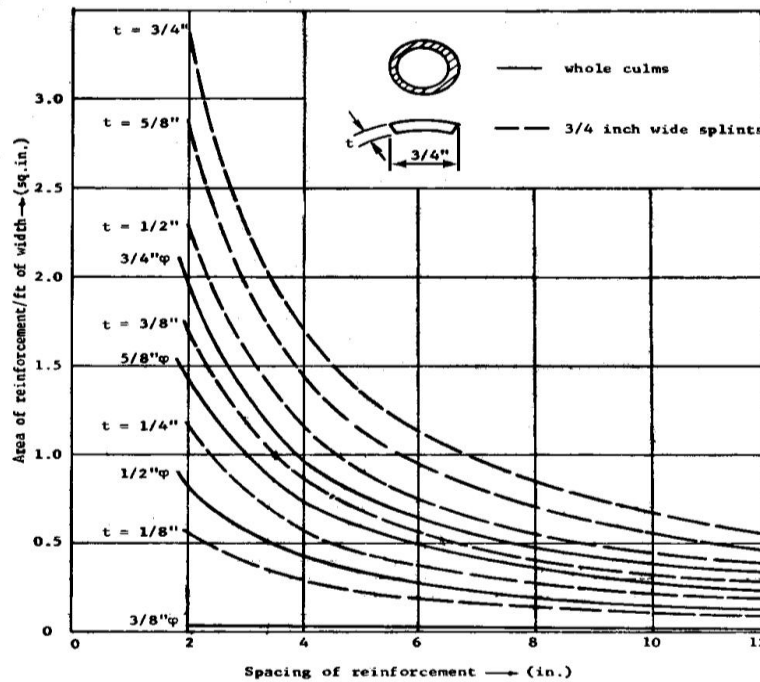

Figure 3- Size and spacing of bamboo reinforcement in slabs and walls.

VI. RESEARCH METHODOLOGY

To show the advantage of bamboo reinforcement in place of steel, building components are designed using steel and bamboo as a reinforcement. Further estimation of reinforcement is done.

1. In this project we have opted advanced bamboo reinforcement technique instead of traditional steel reinforcement.
2. This is a good idea for low cost economical structure.
3. Bamboo reinforcement technique is used for both main and distribution reinforcement as it was same earlier done for steel reinforcement.
4. It is three times cheaper than steel reinforcement technique.
5. Design principal and calculation done for bamboo reinforcement are taken from US NAVAL CORPS guidelines and references.
6. It is clear from results that this bamboo reinforcement technique is absolutely cheaper than steel reinforcement technique especially for single story structure.
7. In future it has a great wide scope for designing multi-story structure using bamboo reinforcement.

International Journal of Innovative Research in Science, Engineering and Technology

(A High Impact Factor, Monthly, Peer Reviewed Journal)

Visit: www.ijirset.com

Vol. 6, Issue 12, December 2017

VII. DESIGN OF BUILDING

Design of Slab

1. **Effective span** -In case of continuous slab, if the width of the support less than $1/12$ of the clear span, the effective span shall be the distance between center of supports or the clear distance between supports plus the effective depth of the slab, whichever is smaller.
2. **Limiting stiffness** -The ratio of span to effective depth should not exceed 26. Modifications factor for tension reinforcement will be extra.
3. **Moment and shear coefficient** -Same rules as for continuous beams given in clause A-10
4. **Reinforcement and its arrangement** -The rules for main reinforcement and transverse/ distribution reinforcement re the same as discussed for simply supported one way slab. However the code IS456:2000 makes the following recommendations.

1. Positive moment reinforcement

At least $1/3$ rd positive moment reinforcement in simple members and $1/4$ th in continuous member shall extend along the same phase of the member into the member to a length = $Ld/3$.

2. Negative moment reinforcement

At least $1/3$ rd of the total reinforcement provided for negative moment at the support shall extend beyond the point of inflexion for a distance not less than the effective depth of the member.

VIII. DESIGN OF BEAM

1. **Calculation of constants.** -For the given set of stresses, determine K_c , J_c and R_c .
2. $K_c = M_{cbc} / M_{cbc} + \sigma_{st}$
3. $J_c = 1 - (K_c / 3)$
4. $R_c = 0.5 * L * K_c J_c$
5. **Calculation of bending moment.** Assume suitable values of overall depth and breadth of beam, and determine the effective span. Calculate self-weight and total U.D.L. and maximum bending moment in the beam.
6. **Design of the section.** Calculate the effective depth of the beam by the expression:
7. $d = [(M) / (R_c * b)]^{0.5}$
8. **Reinforcement.** Calculate the area by the formula.
9. **Shear Reinforcement.** Calculate the maximum shear force in the beam.
10. **Check for Development length** at the end.
11. $L_d \leq (M / V) + L_0$.

Design of column

1. Determine the Permissible stresses in concrete, longitudinal bars and ties.

International Journal of Innovative Research in Science, Engineering and Technology

(A High Impact Factor, Monthly, Peer Reviewed Journal)

Visit: www.ijirset.com

Vol. 6, Issue 12, December 2017

2. Find super impose load the column is required to carry.
3. Determine the area from the following expression - $P = \rho_{cc} * A_c + \rho_{sc} * A_{sc}$.
4. After having known the area, determine the dimensions of column. If it is a square of side b, then $b = \sqrt{A_g}$.
5. For the given end conditions determine effective length of column. Calculate l_{ef}/b ratio to find whether it is a short or long column.
6. If l_{ef}/b ratio < 12 it will be designed as short column otherwise as long column determine the area of steel A_{sc} .
7. Find the diameters of bars used as ties and determine its pitch as per rules.

IX. DESIGN OF FOOTING

The width B of the footing will evidently be equal to $[W + W^*]/q_o$. The thickness is calculated both from the considerations of bending moment as well as punching shear.

1. Depth for bending moment.
 $d = [M/B * R_c]^{0.5}$
2. Depth for shear.
3. $t_v = V/B * d$
4. Steel Reinforcement. $A_{st} = M/t_j c d$

Check for development length.

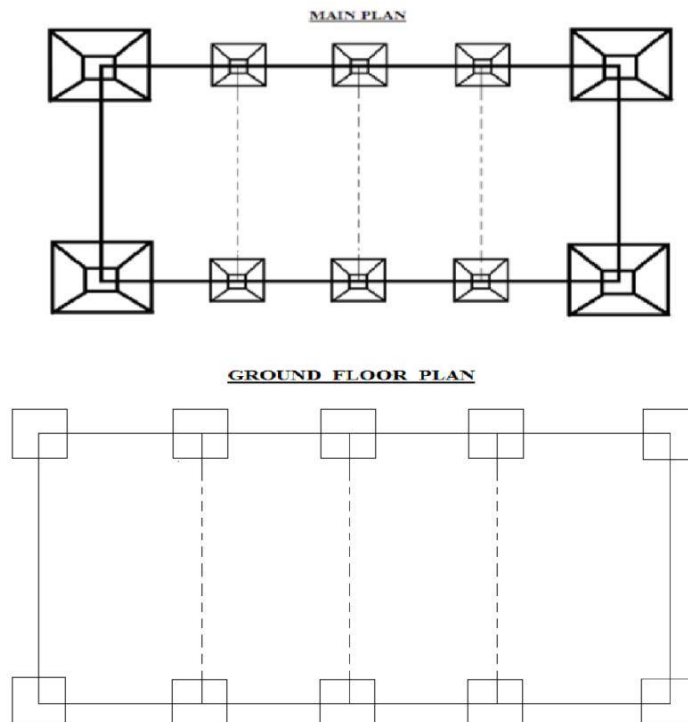

International Journal of Innovative Research in Science, Engineering and Technology

(A High Impact Factor, Monthly, Peer Reviewed Journal)

Visit: www.ijirset.com

Vol. 6, Issue 12, December 2017

$$\begin{aligned} L1 &= 3.9 - 2 * .025 + .42 * .080 \\ &= 3.9 - .05 + .0336 \\ &= 3.88 \end{aligned}$$

$$\begin{aligned} L2 &= 7 - 2 * .025 + .42 * .080 \\ &= 6.98 \end{aligned}$$

$$\begin{aligned} \text{No. of bars} &= (7 / \text{spacing}) + 1 \\ &= (7 / 215) + 1 \end{aligned}$$



$$= 34$$

$$\text{No of distribution bars} = (12 \text{ m} / \text{spacing}) + 1$$

$$\text{Cost} = 50 \text{ Rs} / \text{Kg}$$

$$= 50 * 407.42$$

$$= 20371 \text{ Rs}$$

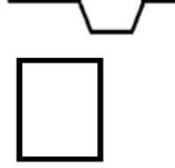
RCC Beam Description of bar	Shape of bending	Length	Number	Total length	Weight
Main straight bar		6.95	2	13.9	1.58 * 13.9
Main bent up bar		7.496	1	7.496	1.58 * 7.496
Stirrups		1.764	25	42 Total = 63.396	1.58 * 42 = Total = 100.16 Kg

$$\begin{aligned} \text{Length } L1 &= 7 - 2 * .25 \\ &= 6.95 \end{aligned}$$

$$\begin{aligned} L2 &= 6.95 + .42 D * 2 \\ &= 7.496 \end{aligned}$$

Calculation of stirrups

$$\begin{aligned} A1 &= \text{side cover} - \phi \\ &= .7 - 2 * .025 - 0.016 = .634 \text{ m} \end{aligned}$$

$$A2 = .25 - 2 * .025 - .016$$

International Journal of Innovative Research in Science, Engineering and Technology

(A High Impact Factor, Monthly, Peer Reviewed Journal)

Visit: www.ijirset.com

Vol. 6, Issue 12, December 2017

= .184 m, Therefore: $2 * (.634 + .184) + 8 * \phi = 1.764$ Cost =
Rs 50 per Kg, Total = $50 * 100.16 = 5008$ Rs

Length L1 = $3 - 2 * .025 = 2.95$

L2 = $2.95 + .42 D * 2 = 3.496$

Calculation of stirrups

$A1 = \sqrt{} - 2 * \text{side cover} - \phi = .242$

$A2 = .25 - 2 * .025 - .08 = .192$, Therefore = $(A1 + A2) 2 + 8\phi = .932$, Cost = $83.25 * 50 = 4162.984$ Rs

X. FOOTING WITH COLUMN STEEL REINFORCING BAR INCLUDING BENDING

1. 8 mm dia bar ϕ .39 Kg in Base Footing

$L = 1200 - 2 * \text{cover}$, $1200 - 2 * 25 = 1.15$ M, No. of bars $(1200/250) + 1 = 5.8$ $\sigma = \sigma$ 6 bars

Weight of steel in base footing = $2 * 6 * 1.15 * 0.39 = 5.38$ Kg, 2. 20 mm dia bar ϕ 2.47 Kg in column above
Ground level

$L = 3$ m, No. of bar = $(3000/250) + 1 = 13$

$13 * 3 * 2.47 = 96.33$ Kg, Below Ground Level = $L = 0.2$ m, $0.2 * 2.47 * 1 = 0.494$ Kg Total
steel = $5.38 + 96.33 + .494 = 102.204$ Kg Abstract of cost

Quantity of steel reinforcement bars = 102.204, Cost Per Kg of steel = 50 Rs/Kg
Amount = $102.204 * 50 = 5110.2$ Rs

Calculation

$L1 = 3.9 - 2 * .025 + .42 * .080 = 3.9 - .05 + .0336 = 3.88$

$L2 = 7 - 2 * .025 + .42 * .080 = 6.98$,,

No. of bars = $(7 / \text{spacing}) + 1$
 $= (7 / 215) + 1 = 34$

No of distribution bars = $(12 \text{ m} / \text{spacing}) + 1$, Cost = $914.66 * 10 \text{ Rs/m} = 9146.6$ Rs

$A1 = \sqrt{} - 2 * \text{side cover} - \phi = .3 - 2 * .025 - .015 = .235$

$A2 = .25 - 2 * .025 - .015 = .185$

Therefore: $(A1 + A2) 2 + 8\phi = .96$, Rate 10 Rs, Cost = $45.359 * 10 = 453.59$ Rs

XI. BAMBOO REINFORCEMENT IN COLUMN AND FOOTING

9.525 Dia Bars in base footing, Length = $1200 - 2 * \text{cover}$ $1200 - 2 * 25 = 1.15$ m

No. of bars = $(1200 / 250) + 1 = 6$ Bars, 20 mm dia bars in columns above ground level $L = 3$ m

International Journal of Innovative Research in Science, Engineering and Technology

(A High Impact Factor, Monthly, Peer Reviewed Journal)

Visit: www.ijirset.com

Vol. 6, Issue 12, December 2017

No. of bars (3000/250) +1 = 1, below ground level length = .2 m, No of bars = 1

Total cost = 2*6* 1.15 *10 +3*13*10+.2*1*10 =Rs 530

XII. RESULTS AND DISCUSSION

Final analysis on estimation of both steel and bamboo Reinforcement:-

Item	Steel (Rs)	Bamboo (Rs)
Slab	20371	9146
Beam 1	5008	640
Beam 2	4162	454
Column & Footing	5110	530
TOTAL	Rs 33,072	Rs 10,770

Comparison between Cost of steel and Bamboo reinforcement concludes with the result that Structures reinforced with bamboo as reinforcement is found cheaper than that of with Steel reinforcement

XIII. ANALYTICAL STUDIES AND RESEARCH

Tjerk Reijenga “Role of Bamboo in Green Building Design”. In this project we are comparing steel reinforcement with bamboo reinforcement, its structural and constructional cost and techniques of replacement of steel with bamboo while reinforcing.

Ghavami (1995) discussed the mechanical properties of Bamboo, specifically pertaining to Bamboo in concrete. This study showed that the ultimate load of a concrete beam reinforced with Bamboo increased 400% as compared to un-reinforced concrete. It was found that, compared to steel, there was lower bonding between the bamboo and concrete, and the Bamboo had a Modulus of elasticity 1/15 of steel. Bamboo’s compressive strength was much lower than its tensile strength, and there was high strength along the fibres, but a low strength transverse to the fibres. Stated is the need for the development of a simple design code for the application of Bamboo as a construction material.

The United States Naval Civil Engineering Laboratory (1966, 2000) reported a study providing a set of instructions on how to properly construct a variety of structures and structural elements using Bamboo. This study suggested not to use green, unseasoned Bamboo for general construction, nor to use un-waterproofed Bamboo in concrete. Concerning Bamboo reinforced concrete, it was found that the concrete mix designs may be the same as that used with steel, with a slump as low as workability will allow. It was recommended that the amount of Bamboo reinforcement in concrete be 3- 4% of the concrete’s cross-sectional area as the optimum amount. It concludes that Bamboo reinforced concrete is a potential alternative light construction method at a low cost.

Amada et al. (1997) investigated the mechanical and physical properties of Bamboo. They conducted a thorough investigation into the structure and purposes of the nodes, which they found to strengthen the Bamboo Culm. They also commented on the advantage Bamboo has over other natural building materials with its fast growth rate.

International Journal of Innovative Research in Science, Engineering and Technology

(A High Impact Factor, Monthly, Peer Reviewed Journal)

Visit: www.ijirset.com

Vol. 6, Issue 12, December 2017

Masani (1977) conducted an in-depth study outlining the proper ways to utilize Bamboo in construction. A listing of the positive aspects of Bamboo is given, citing examples pertaining to its economical, mechanical, and environmental properties. When used as reinforcement in concrete, directions are given to insure a better performance, including discussions on waterproofing, pressure-treating, concrete design, and beam design. This study found that the Bamboo reinforcement area should be 5 times the typical steel reinforcement area, and that even when fine cracks develop on the surface of Bamboo, the load carrying capacity of the member is not reduced. The only negative properties of Bamboo given are its susceptibility to attack by insects, fungi and dried bamboo is prone to catch fire.

Amada and Untao (2001) studied the fracture properties of Bamboo. In contradiction to other studies, this study states that the tensile strength of Bamboo fibres almost corresponds to that of steel. The main discovery is that the fracture properties of Bamboo depend upon the origin of fracture. In the nodes, it is found that the average fracture toughness is lower than the minimum value of the entire Culm, suggesting that the fibres in the nodes do not contribute any fracture resistance.

Power (2004) tells of a study conducted by the U.K. Department of International Development in response to a devastating earthquake that killed 40,000 people in Iran. The engineers were looking for cheap earthquake-proof housing to take the place of mud brick. They constructed a prototype Bamboo reinforced concrete house and used an earthquake simulator to find that the house stood sound during a 7.8 (on the Richter scale) earthquake. They found no cracking in the concrete, the Bamboo to be extremely resilient to earthquakes, and the cost to be split in half compared to mud-and-brick construction.

Seinfeld (2001) researched the remarkable current uses of Bamboo around the world. In the United States, it is almost completely used as decoration. A discussion is presented on the astonishing feature Bamboo brings to the table as mentioned in other articles. Another special feature about Bamboo is that harvesting Bamboo does not harm the plant, producing more of its timbers. Bamboo buildings are definitely a prospect of the future in the US; however in Asia, the Pacific islands, and South & Central America, they are quite traditional. The main prevention of Bamboo structures in America are building codes. There are not standardized codes for buildings of Bamboo though there are attempts towards them. Bamboo is also still being looked at as a way to clean environmental pollution. It is a consumer of Nitrogen, which could soon be part of a huge effort to prevent air pollution.

The American Bamboo Society (2005) provided a very intricate collection of specialized terms followed by their definitions relating to Bamboo. It also has a glossary of questions and answers common to someone new to the topic. These questions ranged from identifying Bamboo, preserving Bamboo, finding help with your Bamboo, to other topics not as closing connected to the research of this project.

A study reported in International Network for Bamboo and Rattan (INBAR) (2002) considered the advantages and disadvantages of Bamboo used as a structural material. The advantages found in their study concluded to be areas of: ecological value, good mechanical properties, social and economic value, and energy consumption. They found disadvantages to be: preservation, fire risk, and natural growth.

XIV. CONCLUSIONS AND SCOPE FOR FUTURE WORK

In this project we have opted advanced bamboo reinforcement technique instead of traditional steel reinforcement. This is a good idea for low cost economical structure. Bamboo reinforcement technique is used for both main and distribution reinforcement as it was same earlier done for steel reinforcement. It is three times cheaper than steel reinforcement technique. It is clear from results that this bamboo reinforcement technique is absolutely cheaper than steel reinforcement technique especially for single story structure.

International Journal of Innovative Research in Science, Engineering and Technology

(A High Impact Factor, Monthly, Peer Reviewed Journal)

Visit: www.ijirset.com

Vol. 6, Issue 12, December 2017

XV. SCOPE FOR FUTURE WORK

Bamboo is a versatile material because of its high strength-to-weight ratio, easy workability and availability. The Analysis of the replacement of steel with bamboo as reinforcement shows that reinforcement with bamboo is quite cheaper than that of steel reinforcement. The positive attributes of Bamboo are listed, supporting its environment-friendly nature. But there are some negative attributes of Bamboo were also given, focusing on its tendency to absorb water. Of those, the bonding between the Bamboo and concrete is considered the biggest problem due to absorption of water and smooth wall of the Bamboo Culm. Also there is a need for the development of a simple design code for the application of Bamboo as a Construction material. Several Researches are ongoing to overcome these problems. Many new techniques are being developed which may make bamboo the best constructional material in future. It has wide scope in Low Cost Constructions.

REFERENCES

- [1] Bhalla , S., Janssen J.A.J “ Design Bamboo As Green Alterative To Concrete And Steel For Moder Structures.”
- [2] Chariar.V.M., “Fabrication and Testing of Jute Reinforced Engineered Bamboo Structural Elements.”
- [3] Dutta, B.N. “Estimate & Costing in Civil Engineering.”
- [4] Francis E. Brink and Paul J. Rush “Bamboo Reinforced Concrete Construction.”
- [5] Jules.J. “Designing and Building with Bamboo.”
- [6] Punamia,B C., Jain, A., Jain,A.K. “ RCC Designs (Reinforced Concrete Structure)”
- [7] Reijenga,I.T. “The Role of Bamboo in Green Building Design.”
- [8] Varghese,P.C, “Design of Reinforce Concrete Structure.”
- [9] H. E. Glenn. "Bamboo reinforcement in portland cement concrete,"
- [10] E. F. Smith and K. L. Saucier. Vicksburg, Mississippi, "Precast concrete elements with bamboo reinforcement,"
- [11] S. R. Mehra and R. G. Ghosh. "Bamboo-reinforced soil-cement," Civil Engineering and Public Works Review, Vol. 60, no. 711, October 1965; vol. 60, no. 712. November 1965.
- [12] "Concrete floors on ground," Portland Cement Association Concrete Information, ST-51.
- [13] American Concrete Institute. "Building code requirements for reinforced concrete," (ACI 318 -56). May 1956.
- [14] Department of the Navy, Bureau of Yards and Docks. Design Manual NAVDOCKS DM-2, Structural Engineering. October 1964.