

Multiple Account Access using Single ATM Card

Sivaranjani.S¹, Suganthi.I², Usha.V³, Vinitha.M⁴, Smitha Gayathri.D⁵

UG Scholar, Department of ECE, Adhiyamaan College of Engineering, Hosur, Tamilnadu, India^{1,2,3,4}

Associate Professor, Department of ECE, Adhiyamaan College of Engineering, Hosur, Tamilnadu, India⁵

ABSTRACT: The idea behind this paper is to embed more than one bank account into single smart card so that the user can transact as he/she wishes with a single swipe. It provides the user one level higher convenience for accessing multiple accounts. The hardware used is PIC microcontroller. Here the microcontroller acts like a smart card that holds the unique card number. In this proposed system admin module and user module are used. Admin module is responsible for entering the user details, user bank details, ATM card details. It is also responsible for clubbing of all accounts of an individual user and updating the database frequently. User module is the interactive module through which the user can log into the system and perform the transactions of the user's choice. Hereby, the users can access multiple accounts by entering a single PIN number.

KEYWORDS: Multiple account access, ATM Cards, Smart card

I. EXISTING METHOD

In modern ATMs, the customer identifies himself or herself by inserting a plastic smart card which contains Card Identification Number (CIN) and some information. The main authentication for ATM transaction is the Personal Identification Number (PIN) of four digits that is used by the customer to access the ATM machine in order to make transactions. There is a limitation in transaction for the other bank customers in using the ATM of some other bank crossing the limit they have to pay the transaction fee.

A. EXISTING METHOD DISADVANTAGES

- User has to carry more than one ATM card for more number of bank accounts and also user has to remember password for each ATM card.
- User has to pay extra charges when transactions are done from different bank's ATM other than ATM card after fee transactions over.
- There is no OTP (One Time Password) system technology.

II. PROPOSED METHOD

The idea behind this embedded smart ATM card is that the customers can use a single ATM card to operate different bank accounts instead of having individual card for each bank account. In this the user swipes his/her smart card in the ATM machine, then it request for OTP in the server side. After selecting the bank the request is sent to the corresponding bank through a network and links it with the banks server for accessing the database of the user so that the transaction is processed.

A. PROPOSED METHOD ADVANTAGES

- User can perform transactions for all his bank accounts using single ATM card.
- Enhanced security system.
- It generates very time new password to customer registered mobile number.
- More user friendly than present system.

III. BLOCK DIAGRAM

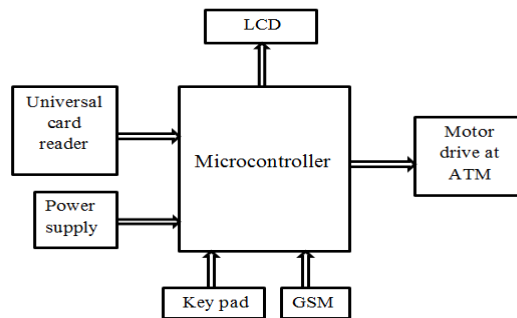

IV. CIRCUIT DIAGRAM

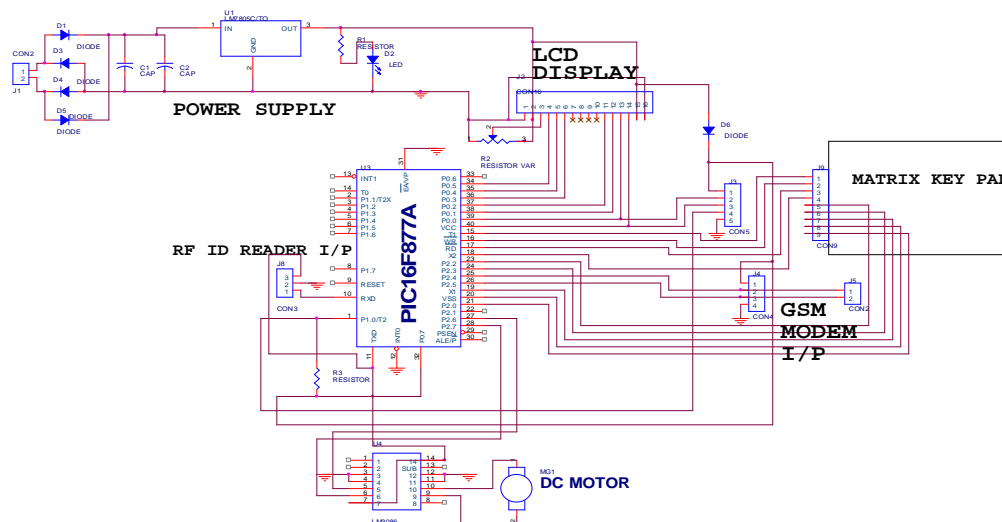

A. CIRCUIT EXPLANATION

The input to the circuit is from transformer it the passes through the power supply circuit. PIC microcontroller which stores the data and keypad which is also acts as the input. Once the card is sensed by the RFID through GPS the number is sent to the concerned phone and it is entered with the help of keypad. The output of this circuit is the motor drive and LCD.

V. CONCLUSION

In this project user can manage his/her multiple accounts in various banks with the help of this single smart card ATM which provides easy access and reduces the complexity of managing more than one ATM card and their respective passwords. In this project OTP provides a more viable method of identifying users sufficient security level for the ATM system. The security features were enhanced largely for the stability and reliability of owner recognition. The whole system is built on the technology of embedded system which makes the system safe, reliable and easy to implement. Hence the vulnerabilities of the ATM fraud will be reduced in future.

International Journal of Innovative Research in Science, Engineering and Technology

An ISO 3297: 2007 Certified Organization

Volume 6, Special Issue 3, March 2017

5th National Conference on Frontiers in Communication and Signal Processing Systems (NCFCSPS '17)

13th-14th March 2017

Organized by

Department of ECE, Adhiyamaan College of Engineering, Hosur, Tamilnadu, India.

REFERENCES

- [1] Gokul.R , Godwin Rose Samuel.W, Arul.M, Sankari.C, “Multi Account Embedded ATM Card” International Journal of scientific & Engineering Research, April-2013.
- [2] Ronald Petrlic University of Paderborn, “Integrity Protection for Automated Teller Machines”, International Joint Conference of IEEE 2011.
- [3] Dr. Marc Lassus, “smart cards: accost effective solution against electronic fraude,” no.437, IEEE 2005.
- [4] H. Lasisi and A.A. Ajisafe , “Development of stripe biometric based fingerprint Authentications Systems in automated teller”, IEEE 2nd International Conference on Advances in Computation Tools for Engineering Applications, 2012.
- [5] Harshal M. Bajad1Sandeep E. Deshmukh2pradnya R. chaugule3Mayur S. Tambade4, “Universal ATM Card System”, International Journal of Engineering Research & Technology (IJERT), October-2012.