

Safety Assured Reliable Microgrid

G.Vasavi¹, V.Kaviya², R.Geethamani³

UG Student, Dept. of EEE, Sri Krishna College of Engineering & Technology, Coimbatore, Tamilnadu, India ^{1,2}

Assistant Professor, Dept. of EEE, Sri Krishna College of Engineering & Technology, Coimbatore, Tamilnadu, India³

ABSTRACT : The Microgrid is a small scale power system which is composed of distributed generators, distributed storage systems and loads. Nowadays, it is preferred to integrate renewable energies in microgrid in order to reduce the emission of CO₂ emission and fossil fuel consumption. The benefits of distributed energy resources are seem to be higher reliability of service, better quality of power supply and greater efficiency of energy use by utilizing the available waste heat from power generation systems. The Distributed generation systems(DES) can benefit the electric utility by reducing congestion on the grid by reducing the need for new generation and transmission capacity, and offering ancillary services. Microgrid control is the key technology in the process accessing microgrid into regular grid. Voltage, frequency and power quality are three main parameters that must be considered that controlled to accepted standards while the power and energy balance is maintained. This paper deals with monitoring and controlling voltage fluctuations using IOT(Internet of Things). Transformation of Microgrid system today into the intelligent robust energy delivery system in the future by providing significant reliability and security benefits.

KEYWORDS : Distributed Energy System(DES), voltage control, Microgrid central control.

I.INTRODUCTION

With the development of renewable energy, energy storage and distributed generation (DG) the microgrid has attracted more and more concern due to its special features. A micro grid consists of a low to medium voltage network of small load clusters with DG sources and storage. Microgrids can operate in an islanded mode or can be connected to the main grid system. If a micro grid is connected to the system, it is seen as a single aggregate load or source. One of the potential advantages of a micro grid is that it could provide a more reliable supply to customers by islanding from the system in the event of a major disturbance. As distributed generator situated close to the load, it has the advantage of reducing transmission losses as well as preventing network congestions. Thus distributed generator can enhance system reliability and stability. Micro grids currently offer various advantages to end- consumers, utilities and society, such as: Improved energy efficiency, improve power quality and reliability, minimized overall energy consumption, reduced green-house gases and pollutant emissions, cost efficient electricity infrastructure replacement.

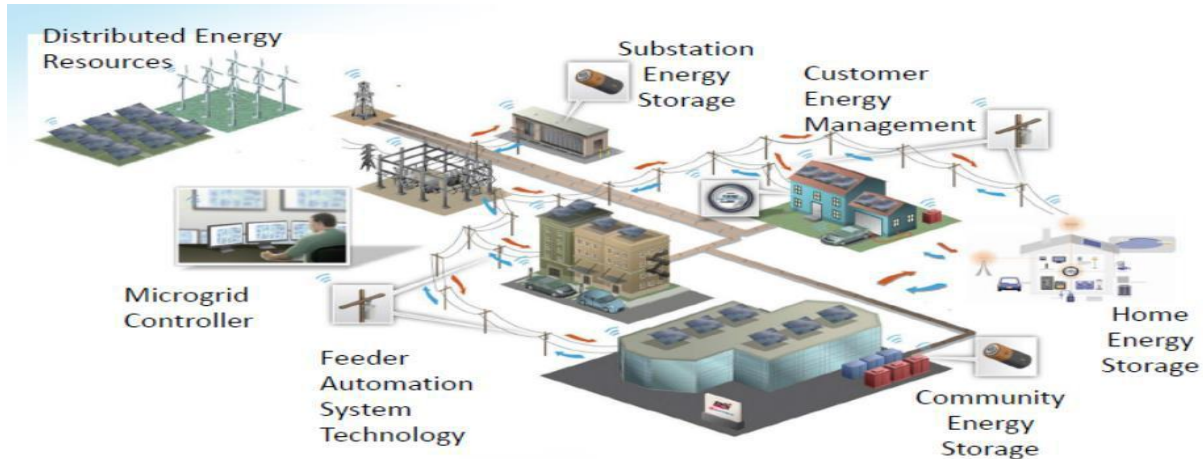

II. STRUCTURE OF MICROGRID

The basic structure of microgrid is showed in Fig. 1. Microgrid presents itself to the bulk power system as a single controlled unit, connecting the grid with the Point of Common Coupling (PCC). DG in microgrid can be various forms of energy, i.e. renewable energy as wind power and PV cell, and non-renewable energy as micro turbine power. Combined Cooling Heating and Power (CCHP) can also provide refrigeration or heating to load. It improves the efficiency of multi-level of energy utilization. Microgrid in figure is radial with three feeders – A, B, and C. PCC is on the primary side of the transformer and defines the separation between the grid and the microgrid. This interface requirement (usually static switch) is to insure the seamless transfer to the island operation or to the grid-connection mode. Feeder A and B in this structure contain sensitive loads (important loads) and multiple DG while feeder C with traditional loads contains no DG. Feeder B also contains a CHP providing DG, which supply both heat and power to the load. Microgrid can island from the grid and with DGS to satisfy the load when there are disturbances on the grid. The traditional loads on feeder C are left to ride through the disturbance by disconnecting SD if there is not enough local generation to meet the demands. PCC and SD will reconnect after disturbances dismiss to make the system go back to the operation state before islanding smoothly.

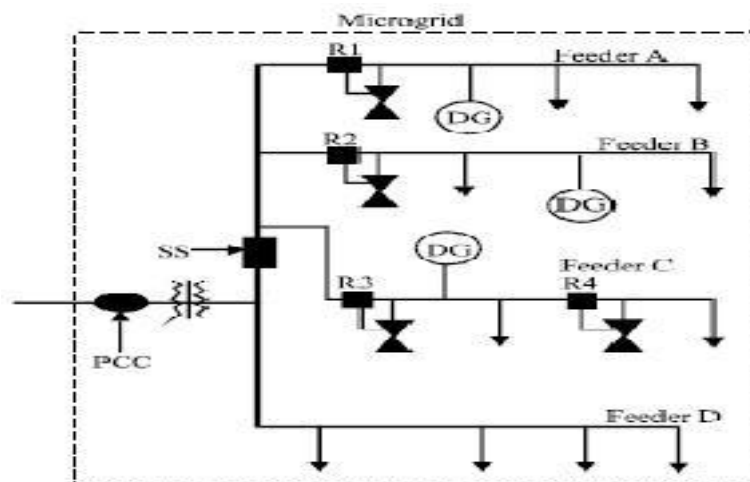
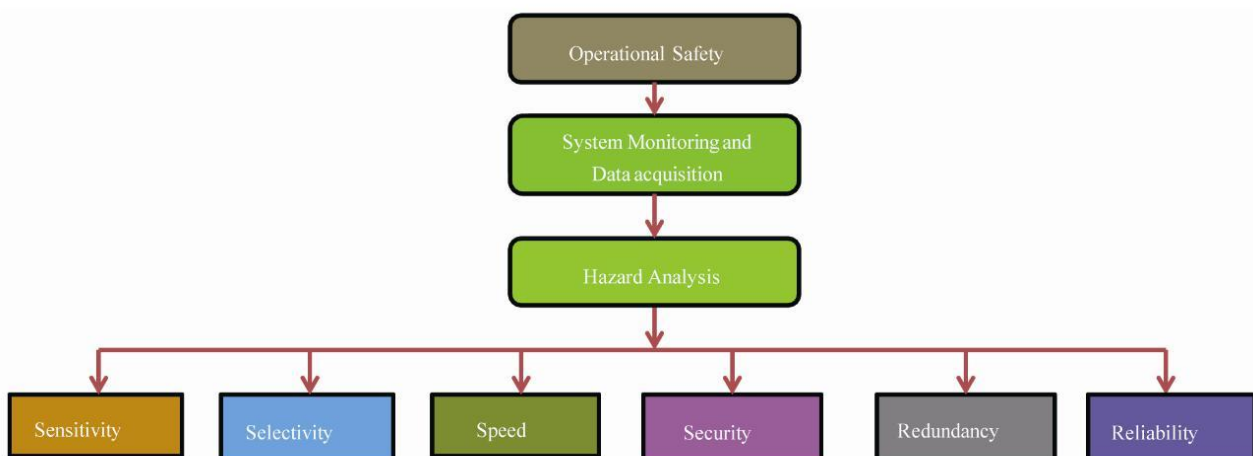

FIGURE 1

III. OPERATIONAL SAFETY DESIGN CONCEPT OF MICROGRID

Safety analysis or safety design concept is important in microgrid protection and their fault analysis. Proper safety model provides appropriate level of confidence in protection system. The intelligent control and monitoring unit need to meet the safety requirements which provide on basis of safety design criteria. Proposed operational safety of microgrid is shown in Figure. Central control and protection system should design to ensure required safety. Micro grid hazard analysis is important to design safety system and based on hazard level different safety threshold is settled. For microgrid safety design there are six parameters need to be considered. The first one is sensitivity, there should have nominal threshold value and control/protection system able to identify any abnormal condition. This nominal value should be set considering safety level of all power system equipment's. Second is selectivity, when fault detected in a system based on voltage, current and power direction fault zone is determined. In order to minimize fault consequence, the protection/control system should disconnect only the faulted part (Disconnect smallest possible part containing the fault). Third one is speed, in order to avoid damage to equipment and maintain stability protective relay should respond in the least possible time in any abnormal condition. This is very important from safety point of views. The security level should be high, all the abnormal conditions/events of power system are not fault. So protection/control system should operate only when required to operate, reject all abnormal events and transients hose are not fault. And the protection system should be designed to avoid mis operation while itself experiencing a credible failure. There should have redundancy options, redundant system are planned and referred as backup protection to ensure level of safety. The protection system should have redundant functionalities of relays to improve system reliability and safety. Different protection principle could be combining to reach protection redundancy. The reliability should be high, modern power system with distributed generator becoming more dynamic structure, so now reliability becomes important topic in control and protection system analysis. Based on different system condition there should have option for different relay setting. To improve modern protection and control system reliability and faster restoration of outage, we can use microprocessor based distribution relay or digital relay.



IV. FAULT ANALYSIS OF MICROGRID

In micro grid fault analysis we can categorize mainly two type, external fault (main grid) and internal fault (micro grid). External fault could be in MV bus or distribution transformer and internal fault could be in LV feeder or LV consumer. As micro grid need to operate in both is- land and grid connected mode there have challenge in micro grid protection system with conventional protection strategy. The major micro grid protection problem is related to large difference between fault current in main grid connected and islanded mode. Also there have sensitivity and selection problem due to different fault current in different scenario. But it is essential to have high sensitive to faults and selectively

isolate/sectionalize in the case of DGs with low fault current level. As conventional protection system don't offer solution for all micro grid protection challenge, advanced protection strategy required.

Intelligent Protection Techniques for Micro Grid:

Here a model of adaptive/intelligent protection system for micro grid is described below. This advanced protection system can potentially solve the problems identified earlier. The protection scheme must ensure safe operation of the micro grid in both mode of operation, that is the grid connected mode and island mode. Due to contribution of host grid in grid connected mode fault currents are large. This allows to employment of conventional over current relay, but the fact is that due to existence of distributed resources (DRs) the protection coordination may be compromised or even entirely loss in some cases. However, in islanded mode due to limited current contribution of distributed resource fault current may be significantly small compared to grid connected mode. For this reason the conventional over current protection is ineffective in islanded mode of operation. Proposed adaptive protection system can solve the challenge of conventional micro grid protection system. The new protection system modifies the preferred protection response to a change in system conditions

in a timely manner by means of externally generated signal or advanced control actions. For a practical implementation of adaptive micro grid protection the requirements and suggestion can be mentioned as below: Firstly, there would have a micro grid central controller (MCC) and monitoring system in modern micro grid protection system. Communication electronics make each CB with an integrated directional OC electronic trip unit (relay) capable of exchanging information with MCC. Secondly, use of numerical directional OC relays/microprocessor based relay/digital relay because fuses or electromechanical and standard solid state relays are (especially for selectivity holding) in applicable they do not provide the flexibility for changing the settings of tripping characteristics and they have no current direction sensitivity feature. Thirdly, numerical directional OC relays/microprocessor based relays must dispose of possibility for using different tripping characteristics (several settings groups) that can be parameterized locally or remotely automatically or manually. Finally, introduce modern control infrastructure and data acquisition protocols so that individual relays can communicate and exchange information with micro grid central controller (MCC). With this instantaneous settings for different fault scenario which will reliably to guarantee a required application performance. The modern Micro grid protection system with micro grid central control and monitoring system is an important topic to discuss to overcome challenge of conventional protection system. Instantaneous relay settings, current, voltage and power directions are sent to central control unit through micro grid monitoring and data acquisition unit. So with MCC and monitoring unit any abnormal condition or disturbance can be monitor and measure. Based on disturbance data analysis the fault could be detected, when any fault is detected it is important to find fault type based on current state of micro grid and the fault affected area/zone. The main goal of intelligent protection system is to maintain relay setting of each relay with current micro grid scenario. There would be a special module in micro grid central control (MCC) unit which is responsible for periodic check and update of relay settings [1,2]. The Micro grid central control (MCC) can read data (direction, electrical value, status) of individual relays from each CB and if required it can modify subset of relay settings (tripping characteristics). So tripping decision can perform by MCC to each individual relay, in case of any abnormal situation is detected tripping condition is checked and the direction of current is measured compared with actual relay settings.

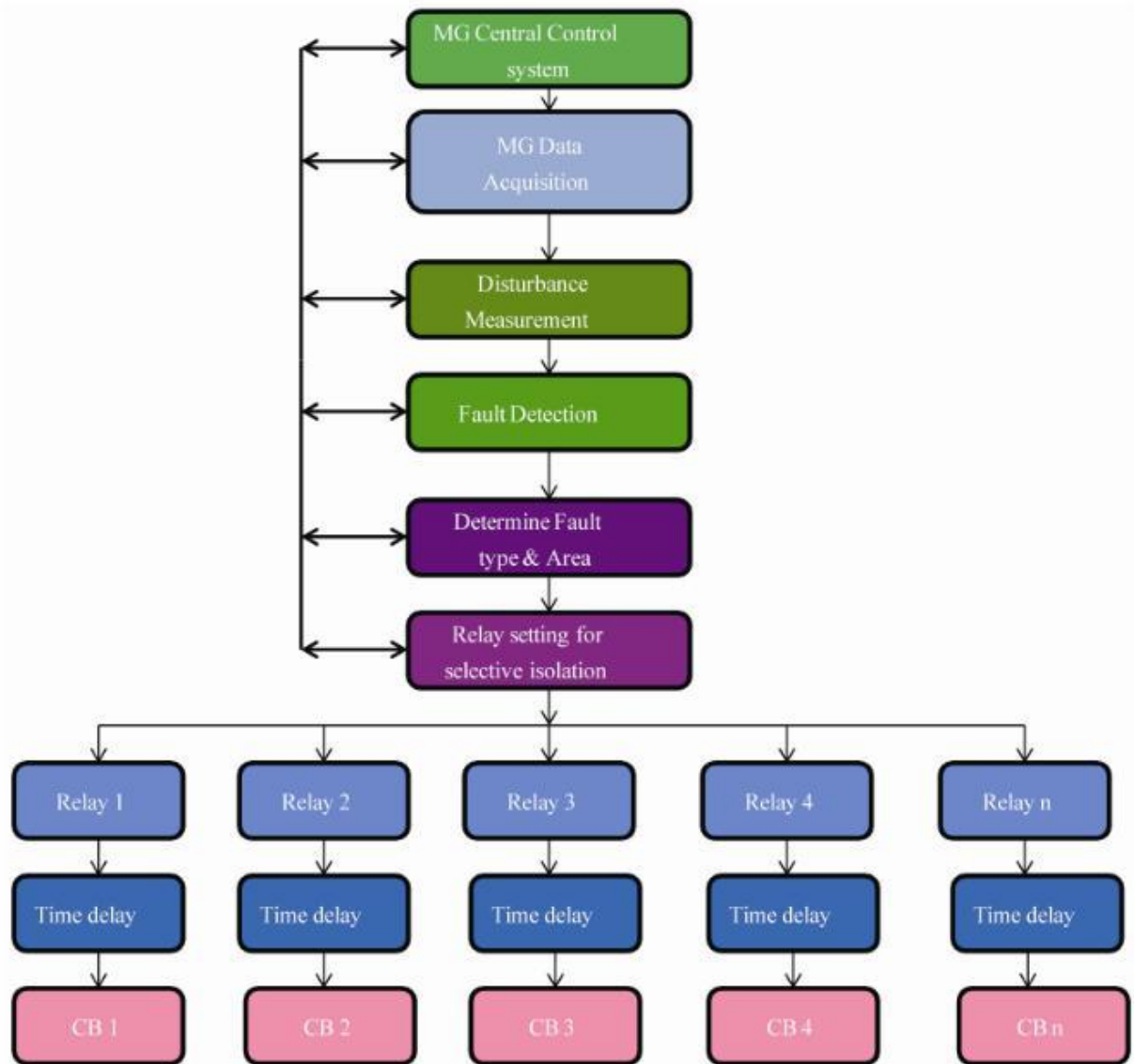

Figure 4. Centralized protection system for micro grid.

V. CONTROL METHODS OF MICROGRID

From the view of the bulk grid system, microgrid is an aggregation unit as a generation or load. On the other hand, microgrid is a power system operates autonomously, supplying reliable and high quality electric power from the view of customer side. Therefore, a good performance microgrid control and management system is needed.

The purposes of microgrid control are as follows:

- New micro sources can be added to the system without modification of existing equipment.
- The microgrid can choose operation point autonomously.
- The microgrid can connect to or isolate itself from the grid in a rapid and seamless fashion.
- Reactive and active power can be independently controlled.
- Voltage sag and system imbalances can be corrected.
- The microgrid can meet the grid's load dynamics requirements

VI. PROTECTION OF MICROGRID

In designing a protection system of any power system, the protection requirements that must be considered are reliability, speed, selectivity and cost . The main function of a protection system is to quickly remove from service any component of the system that starts to operate in an abnormal manner. Other functions are to ensure the safety of personnel, to safeguard the entire system, to ensure the continuity of supply, to minimize damage and to reduce resultant repair cost. When a fault occurs, a protection system is required to disrupt as few section of the system as possible. Selective operation of the protective devices will ensure maximum continuity of service with minimum system disconnection.

Conventional distribution system is designed to operate radially, where only a single source is present. The current flows in one direction from the higher voltage levels at the substation, through the distribution feeders and laterals at lower voltage levels, to the customers loads. Based on this characteristic, the system relies on a simple and low-cost protection schemes that consist of fuses, reclosers, circuit breakers and over current relays . Example of a conventional distribution system with the protective devices installed is shown. Breakers and reclosers are normally installed at the main feeder to allow clearance of temporary faults before lateral fuses blow. In normal condition, breakers and reclosers are equipped with inverse time overcurrent relays which normally installed at the substation where the feeder originates. The protective devices are coordinated to operate according to criteria of selectivity based on current or time so as to ensure the device nearest to a fault will operate first. The basic criteria that should be employed when coordinating time or current devices in distribution systems are :

- The main protection should clear a permanent or temporary fault before the backup protection operates, or continue to operate until the circuit is disconnected. However, if the main protection is a fuse and the back-up protection is a recloser, it is normally acceptable to coordinate the fast operating curve or curves of the recloser to operate first, followed by the fuse, if the fault is not cleared
- Loss of supply caused by permanent faults should be restricted to the smallest part of the system for the shortest time possible

In a traditional distribution system, the protection systems are designed assuming unidirectional power flow and are usually based on overcurrent relays with discriminating capabilities. According to [IEEE \(2003\)](#) for any fault situation, DG sources connected to the system are tripped off. In other words, islanded operation of DG sources is not allowed. When a microgrid is created in a distribution system, the configuration becomes a complex

multi-source power system. The protection philosophy of the microgrid is to assure safe and secure operation of the subsystem in both modes operation, i.e., during interconnected mode and islanded mode. However, the two operating modes pose new challenges in protecting the microgrid. Therefore, two sets of protection settings is the most probable solution to the dual modes of operation. During grid-connected operation, the mains supply large fault currents to the fault point. This makes possible the employment of the existing protection devices in the distribution system. Yet, the protection coordination may be compromised or even entirely lost in some cases due to the installation of DGs. On the other hand, such large fault current contribution from the microgrid cannot always be expected, especially when it is dominated by electronically-coupled DGs. Thus, the use of conventional overcurrent protection in the microgrid is no longer valid due to this low short circuit current contribution from the micro-sources.

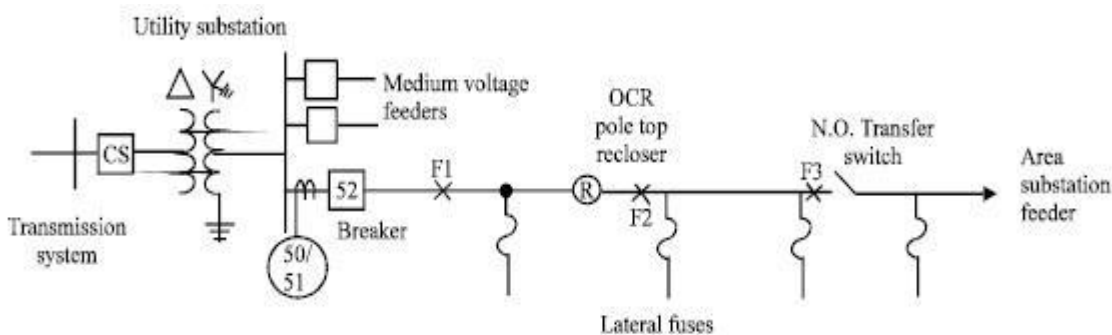

Distribution system with protective devices

It is obvious that alternate means of detecting an event within an isolated microgrid must be studied and new protection schemes have to be devised.

In order to design a microgrid protection system that suits both grid-connected and islanded modes of operation, the following features must be considered:

- The system must be able to respond both to distribution system and microgrid faults
- For a fault on the main grid, isolate the microgrid as quickly as possible
- For a fault within the microgrid, isolate the smallest possible section of the radial feeder carrying the fault to get rid of the fault
- The protection scheme must ensure an effective operation of customers' protection

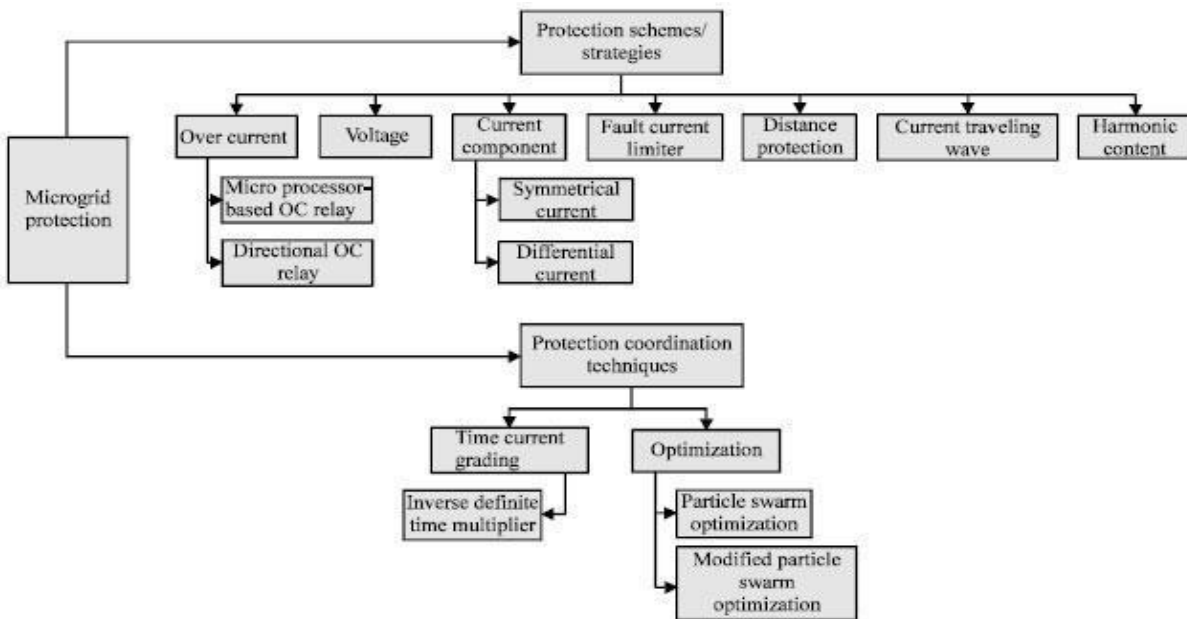

Different types of protection schemes for microgrid operation

VII. MICROGRID PROTECTION SCHEMES

Microgrid protection schemes:

The protection of a microgrid must respond to both main network and microgrid faults. If a fault occurs on the main grid, the desired response is to isolate the microgrid from the main network as rapidly as necessary to protect the microgrid loads. This caused islanding of the microgrid operation. If a fault occurs within the microgrid, the protection system is required to isolate the smallest possible faulted section of the microgrid to eliminate the fault. Various possible microgrid protection schemes and coordination techniques that are available from the literature are summarized. The protection schemes can be divided into over current based, voltage-based, current component-based, harmonic content-based, fault current limiter-based and current traveling wave-based. As for protection coordination techniques, time-current grading and optimization algorithms are used to ensure selectivity of the protective devices. The functionality and reliability of different types of protection schemes have been studied to fulfill different mode of operations, different types of DGs that exist in a microgrid, different issues that it has to tackle like bi-directionality of power flow and location of DG placement.

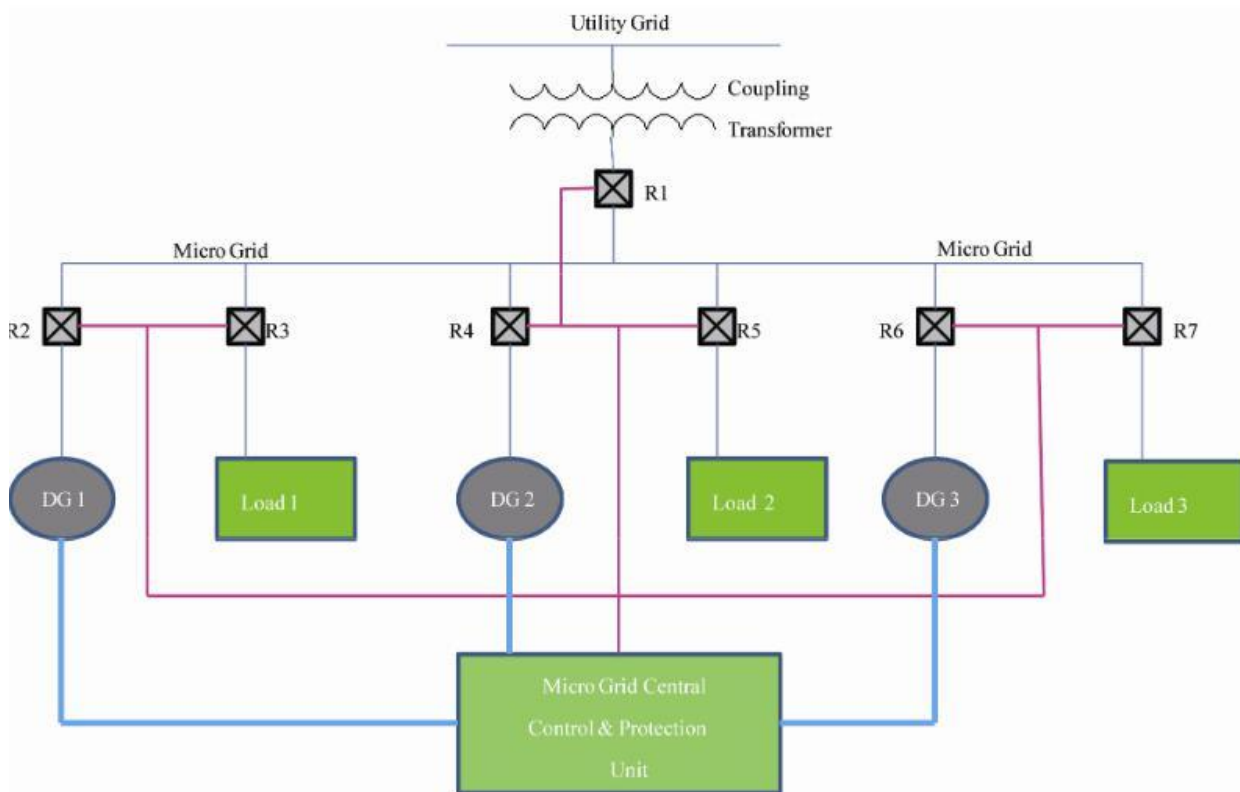

Overcurrent scheme:

Jenkins et al. (2005) simulated a simple microgrid system containing 200 kW flywheel storage system, a number of micro sources and a group of residential consumers, in order to investigate possible protection schemes for a microgrid. Two scenarios are studied, i.e., when microgrid is connected to the main network and when the microgrid is islanded from the main network. For a fault on the main distribution network, overcurrent relay protection and balanced earth fault protection were installed at the grid side of the circuits between the main distribution network and the microgrid, with the capability of inter-tripping the microgrid. Investigation was also made to the test system for different location of faults. For fault on the microgrid, over current relay protection and Residual Current Device (RCD) are used to protect the feeder from the fault. During the fault, the flywheel supplies a high fault current (e.g., 3 p.u based on its rating or above) if the microgrid is operated in islanded mode. After the fault, the protection disconnects the faulty feeder from the microgrid and has the capability of inter-tripping all the micro sources on the feeder at the same time. For a fault at the residential consumer, a Short Circuit Protective Device (SCPD) like Miniature Circuit Breaker (MCB) or fuses and a RCD can be installed at the grid side of the residential consumer. The SCPD is used to protect the residential consumer against the phase to phase and phase-to-neutral faults while the RCD is used for phase-to-ground or earth fault. However, the use of conventional overcurrent protection scheme gives rise to problems such as less sensitivity, refusing to operate and maloperation .

Voltage-based scheme:

The protection scheme based on DG output voltage measurement was used to detect and clear faults. The output voltages were monitored and transformed into dc quantities using the d-q reference frame. Any disturbance at the DG output due to a fault on the network will be reflected as disturbances in the d-q values. Zones of protection and use of communication link between relays to aid the protection scheme in discriminating between in-zone and out of zone faults are also considered. Verification via simulation has been done for different fault locations and different types of faults. However, the proposed scheme is devised for islanded operation only without considering the grid-connected mode of operation and high impedance fault.

The use of voltage based protection scheme for islanded microgrid dominated by inverter-based DGs was presented. In this scheme, a new fault judgement method based on detecting the positive sequence component of the fundamental voltage was used to judge the fault location and fault types in a microgrid. The waveforms of the 3-phase voltages and the voltage magnitudes under symmetrical and unsymmetrical fault conditions were transformed into the d-q reference frame and compared with the amplitude of the fundamental positive sequence voltages in the d-q coordinate system.

VIII. CONCLUSION

In this paper, an intelligent micro grid protection system using digital relaying with central control and monitoring infrastructure is proposed. Safety model is analyzed to improve protection level. Multifunctional Intelligent Digital Relay permits automatic adaptation of protection settings according to the actual type of grid structure and the interconnection of micro grid. These intelligent digital relays allow for continuous measure and monitor analog and digital signal originated from the system. Automated fault analysis is another important requirement for micro grid protection and safety. Modern microprocessor based/digital relay offer new approach based on pattern recognition and accurate fault location which are more reliable and secure than distance protection. The feasibility research on microgrid's smart frequency and voltage control strategy in both the mode of isolated and grid-connected is mentioned.

REFERENCES

- 1.Md Razibul Islam, Hossam A. Gabbar Faculty of Energy System and Nuclear Science, University of Ontario Institute of Technology, Oshawa, Canada. Email: razu_49@hotmail.com, hossam.gabbar@uoit.ca Received October 2nd,2011; revised November 2nd, 2011; accepted November 10th, 2011.
- 2.ICSGCE 2011: 27-30 September 2011, Chengdu, China Survey on Microgrid Control Strategies Wei Huang, Miao Lua*, Li Zhangba North China Electric Power University, Beijing, China. b Engineering at Henan Zhumadian Power Supply Company, China.
- 3.A. Oudalova and A. Fidigattibfd, "Adaptive Network Protection in MICROGRID,"2011. www.microgrids.eu/documents/519.pdf
- 4.H. Nikkhajoei and R. H. Lasseter, "Microgrid Protection," IEEE PES General Meeting, Tampa, 24-28 June 2007