

Design and Analysis of Suspension System of a Student Formula Car

Abishek.R.K¹, Aswin Krishna.M¹, Balaguru.J¹

¹Third Year UG, Department Of Mechanical Engineering ,Kumaraguru College Of Technology, Coimbatore, Tamilnadu, India ¹

ABSTRACT: The objective of our paper is to design the whole suspension system which includes coil springs, control-arms and damper in the double wishbone system for student formula car. First based on the ride rate, wheel rate and motion ratio we calculate the spring rate. Then with the help of it we set the dimensions for the spring. Then CAD modelling of the spring is done using creo parametric. Then we sketch the a-arm by fixing the UCA, LCA axis, UBJ and LBJ points. Then required damper should be selected according to the spring stiffness. Then using MATLAB, system response is generated for the spring, damper and mass assembly. Then we do structural analysis for springs for control arms using ANSYS Workbench(15.6). At last the whole assembly is analysed for Multi Body Dynamics in Hyper works and results are checked.

KEYWORDS: Control arms, Upper control arm axis(UCA axis), Lower control arm axis (LCA axis), Upper ball joint (UBJ), Lower ball joint(LBJ),Multi Body Dynamics in Hyper works.

I.INTRODUCTION

Suspension system is the one of the important system in vehicle. It supports the weight of the vehicle and provides the smooth ride. It allows rapid cornering without extreme body roll and keeps tire in firm contact with the roll and it also prevents excess body squat and body dive. It allows front wheel to turn side to side steering. It also works with the steering to keep the wheels in correct alignment. The basic parts of suspension system aarm (control arm) ,spring, damper ,knuckle etc. In this paper we have designed and analysed the a-arm, spring and whole assembly of the suspension system.

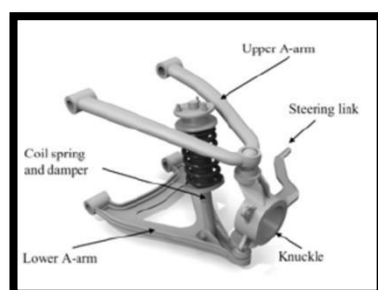

Figure 1:assembly of suspension system

II. DESIGN PROCEDURE FOR SUSPENSION SYSTEM

1. First of all we set the wheel track and wheel base according to the conditions in the sae rulebook.
2. Then we have to select the type of suspension system (eg: double wishbone).
3. Then we have to set the camber, castor, kingpin angle, etc.

International Journal of Innovative Research in Science, Engineering and Technology

An ISO 3297: 2007 Certified Organization

Volume 6, Special Issue 7, April 2017

5th National Conference on Trends in Automotive Parts Systems and Applications (TAPSA-2017)

30th & 31st March 2017

Organized by

Sri Krishna College of Engineering & Technology, Kuniamuthur, Coimbatore-641008, Tamilnadu, India

4. Next, we have to set the ride frequency to calculate the ride rate, roll rate, etc.
5. After that, we have to calculate the spring rate with the help of motion ratio and wheel rate and the spring is designed with the help of spring rate.
6. Then we sketch the a-arm by fixing the UCA, LCA axis, UBJ and LBJ points to achieve the required anti-dive and anti-squat.
7. Then dampers are selected by selecting the right damping ratio which is suited for the stiffness of the springs.
8. Following that, FEA analysis is done for the springs and control arms and the results are checked.
9. The system response is generated for the mass, spring and damper assembly in MATLAB.
10. Then the whole assembly of the suspension system is checked for ride and roll analysis in Hyperworks.

III. SPECIFICATIONS OF THE CAR

Initially we have to set the specifications of our car like wheel base and track, Camber, Castor, Kingpin angle, etc.

Table 1: Specifications of the car

WHEEL BASE(mm)	1550
WHEEL TRACK FRONT(mm)	1250
WHEEL TRACK REAR(mm)	1200
CAMBER	1.5°
CASTOR	3.5°
KING-PIN ANGLE	4°

IV. CALCULATIONS IN THE SUSPENSION SYSTEM

Calculation of spring rate and weight distribution during cornering:

The front ride frequency is set to 2.8 Hz and rear is about 3 Hz. Now using these all other rates are found.

$$K_{rf} = 4 * \pi * \pi * (f^2) * 60 / 1000 = 18.57 \text{ N/mm}; \quad K_{wf} = K_t K_r / (K_t - K_r) = 22.8 \text{ N/mm},$$

$$K_{wr} = K_t K_r / (K_t - K_r) = 47.01 \text{ N/mm}; \quad \text{Motion ratio} = 0.75 \quad \text{and}$$

$$\text{Spring rate } SR = K_{wf} / (IR^2) = 46.54 \text{ N/mm}$$

Weight distribution:

$$W1 = 588.6 \text{ N}, \quad W2 = 588.6 \text{ N}, \quad W3 = 882.9 \text{ N}, \quad W4 = 882.9 \text{ N}, \quad \text{CG height}(h) = 285 \text{ mm},$$

$$\text{Cg to roll axis}(H) = 240 \text{ mm} \quad \alpha = -10 \text{ deg}, \quad R = 24.38 \text{ m}, \quad V = 77 \text{ kph}, \quad z_{rf} = 45$$

$$\text{mm}, \quad z_{rr} = 55 \text{ mm},$$

$$K_{rf} = 18.57 \text{ N/mm}, \quad K_{rr} = 31.97 \text{ N/mm}, \quad T_f = 1250 \text{ mm}, \quad T_r = 1200 \text{ mm}$$

International Journal of Innovative Research in Science, Engineering and Technology

An ISO 3297: 2007 Certified Organization

Volume 6, Special Issue 7, April 2017

5th National Conference on Trends in Automotive Parts Systems and Applications (TAPSA-2017)

30th & 31st March 2017

Organized by

Sri Krishna College of Engineering & Technology, Kuniamuthur, Coimbatore-641008, Tamilnadu, India

$A\alpha$ (Horizontal lateral acceleration) = $v^2/(rg)$ = -1.91g, $A_y = A_a \cos\alpha - \sin\alpha = -1.706$ g ,

$W' = W(A_a \sin\alpha + \cos\alpha) = 3875.36$ N

Effective front load $W'_f = W' * b/l = 1550.144$ N , Effective rear load $W'_r = W' * a/l = 2325.216$ N

Roll gradient = $\phi/(A * y) = -1.131$ deg/g $k_{\phi f} = K_{rr} * t_f^2/2 = 14507.8$ Nm/rad

$k_{\phi r} = K_{rr} * t_r^2/2 = 23018.4$ Nm/rad Front roll rate distribution = 38.66%

Rear roll rate distribution = 61.34%

Front lateral load:

$$W_F = A_Y \times \frac{W}{t_F} \times \left(\frac{H \times K_{\phi F}}{K_{\phi F} + K_{\phi R}} + \frac{b}{\ell} \times Z_{RF} \right) = -424.55 \text{ N}$$

Rear lateral load:

$$W_R = A_Y \times \frac{W}{t_R} \times \left(\frac{H \times K_{\phi R}}{K_{\phi F} + K_{\phi R}} + \frac{a}{\ell} \times Z_{RR} \right) = -758.97 \text{ N}$$

Front load distribution = 35.87%

Rear load distribution = 64.13%

$W_{f_o} = (W'_f/2) + W_f = 1199.622$ N

$W_{f_i} = (W'_f/2) - W_f = 350.522$ N

$W_{r_o} = (W'_r/2) + W_r = 1921.578$ N

$W_{r_i} = (W'_r/2) - W_r = 403.638$ N

Spring Calculations:

Total load = 300 kg; Front load (single wheel) = 60 kg; Assume spring index = 7

By iteration finally we get wire diameter $d = 10$ mm and mean coil diameter = 70 mm

From Soderberg equation,

$$\frac{1}{F_s} = \frac{T_m}{T_y} + \frac{T_a}{T_y} \left(\frac{2T_y}{T_e} \right), F_s = 1.45$$

$N = 8 * P_{max} * D^3 * N / (G * d^4) \Rightarrow N = 6, N_t = 6 + 2 = 8$

International Journal of Innovative Research in Science, Engineering and Technology

An ISO 3297: 2007 Certified Organization

Volume 6, Special Issue 7, April 2017

5th National Conference on Trends in Automotive Parts Systems and Applications (TAPSA-2017)

30th & 31st March 2017

Organized by

Sri Krishna College of Engineering & Technology, Kuniamuthur, Coimbatore-641008, Tamilnadu, India

Solid length $L_s=80$ mm and Free length $L = L_s + \delta_{max} + \delta_{allowance} = 146.5$ mm

Pitch= Free length/(Nt-1)= 20.92 mm

Stiffness $K = \frac{G d^4}{8 * D^3 * N} = 48.56$ N/mm

Spring frequency= $f_{res} = \frac{d}{9D^2 n_t} \sqrt{\frac{G}{\rho}} = 90.487$ Hz

Control arms load calculations:

front load(single wheel)= 60 kg ; 2G force= 1177.2 N force at knuckle point=1177.2/cos(3.36°) = 1179.227 N force at strut point = 1179.227/0.75 = 1572.303 N

Force along strut = 1572.303/sin(51°) = 2023.176 N

Total force on control arms =(1572.303 +1179.227) = 2751.53 N

Sprung and Un sprung calculations:

Front(single wheel):

Un sprung mass =16 kg, Sprung mass = 60-16 = 44 kg Rear(single wheel):

Un sprung mass =18 kg, Sprung mass = 90-18= 72 kg

Total sprung mass = 232 kg Total un sprung mass = 68 kg

Sprung mass damping ratio = 0.5-0.7 (we take 0.7), Un sprung mass damping ratio = 0.3-0.5 (we take 0.5)

Front damping coefficient =578.403 kg/s, Front sprung frequency =(1/2π)*(K_{Rf}/m_s)^(1/2)= 3.084 Hz

Front un sprung frequency=(1/2π)*(K_s+K_v/m_{us})^(1/2)= 20.487 Hz

V. GEOMETRICAL CONFIGURATIONS

First we have to first calculate the spring rate for a particular ride frequency and motion ratio. Then we have to set the spring ratio and assume the wire diameter. With the help of these data then find the factor of safety using soderberg equation. If it is not so good then again change the wire diameter. By this repetitive process find the correct wire diameter. Following it we can find the outer diameter, number of turns, stiffness, pitch, free length of the spring and with these we have to complete the CAD model of the spring

International Journal of Innovative Research in Science, Engineering and Technology

An ISO 3297: 2007 Certified Organization

Volume 6, Special Issue 7, April 2017

5th National Conference on Trends in Automotive Parts Systems and Applications (TAPSA-2017)

30th & 31st March 2017

Organized by

Sri Krishna College of Engineering & Technology, Kuniamuthur, Coimbatore-641008, Tamilnadu, India

For the control arms it is purely done by sketching with the help of LCA and UCA axis, UBJ and LBJ points and anti-dive and anti-squat. Then with that sketch we have to finish the CAD modelling of the control arms. Here, AISI 4130 is used as the material for control arms and chrome vanadium for springs.

Table 2: Geometrical configurations of spring

Suspension spring	Front
Wire diameter (d)	10mm
Outer diameter (D+d)	80 mm
Free length(L)	146.5mm
Pitch(p)	20.92mm
No of turns(n)	6+2=8

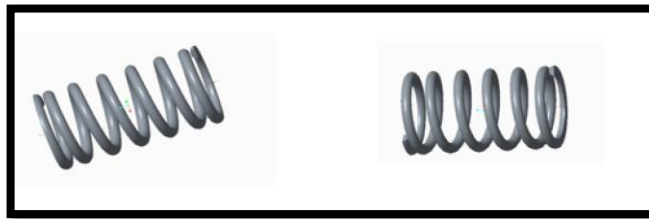

Figure 2 : Design of front and rear spring

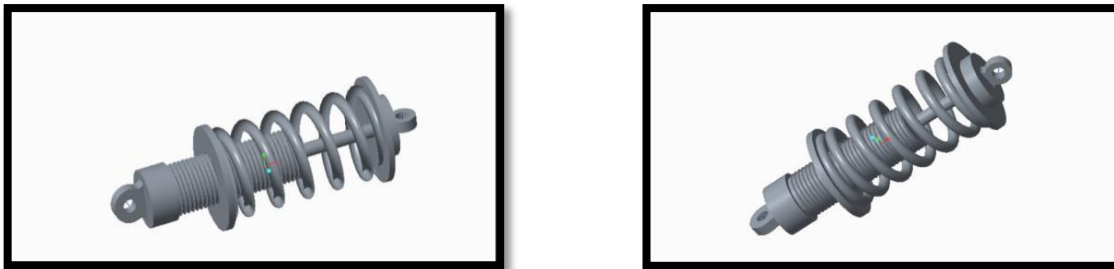

Figure 3: Assembly of spring with damper

Table 3: Specifications of upper arm and lower arm

SPECIFICATIONS	UPPER ARM	LOWER ARM
Control arm top view angle(°)	58.82	56.12
Fvsa(Front view swing arm length) (mm)	262	266
Control arm front view angle(°)	9.94	3.36

Table 4: Material properties for arm material and spring material

PROPERTIES	AISI 4130	CHROME VANADIUM
Density	7.87g/cm ³	7.8 g/cm ³
Young's Modulus, E	205GPa	210 GPa
Poisson's ratio	0.29	0.29
Ultimate Strength	670MPa	940MPa
Yield Strength	460 MPa	620MPa
Shear modulus	80GPa	80 GPa

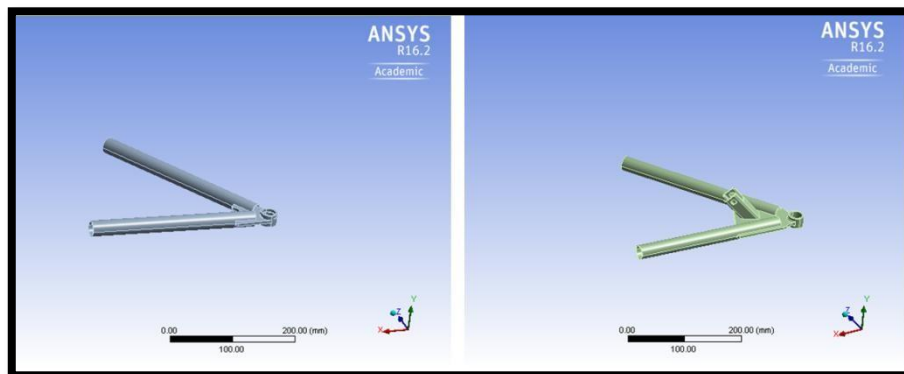

Figure 4: Design of upper and lower A-arm

VI. FINITE ELEMENT ANALYSIS

Springs:

Boundary conditions:

- One end is fixed.
- In other end required load is given.

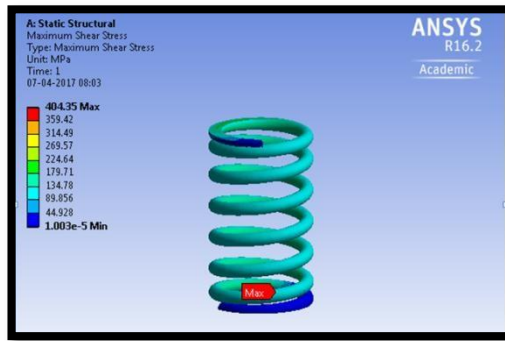

Figure 5 :Max shear stress analysis front spring

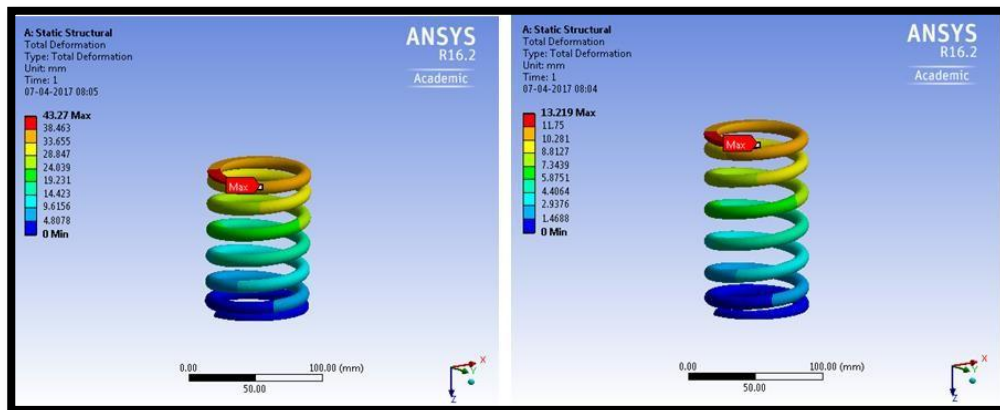

Figure 6 :Deformation at maximum load and at pre-load condition.

Table 5:Summarized results from spring analysis

springs	
Initial deformation (with driver weight)	13.219mm
Deformation at maximum force	43.27mm
Actual deformation	43.27-13.219 = 30.051mm
Equivalent shear stress	404Mpa
Factor of safety	1.53

Control arms:

Boundary conditions:

- By assuming as cantilever beam the ends of a-arm which connects to frame is fixed.
- Required forces are given at knuckle point
In x- axis:1200N(cornering force)

In y- axis: 600N(wheel loads)

In z-axis:500N(braking force)

- In lower control arm addition to those forces, strut force (2024N inclined 47.3° to horizontal) is also acted.

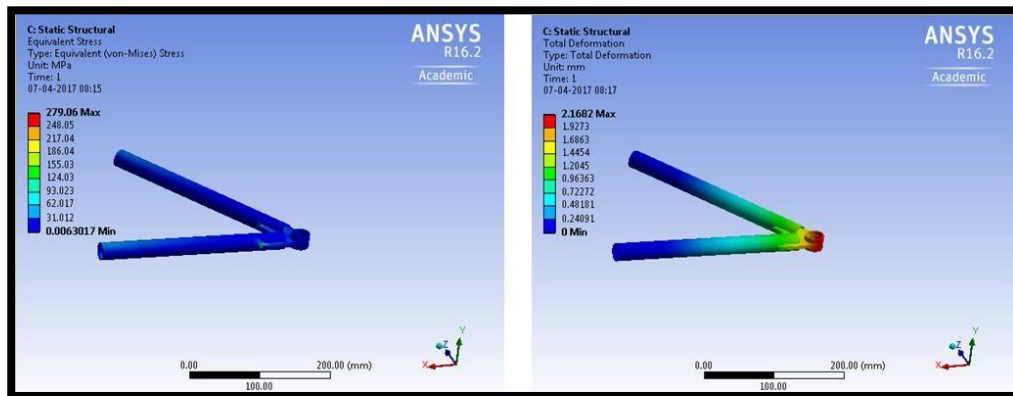

Figure 7: Static analysis of upper A-arm

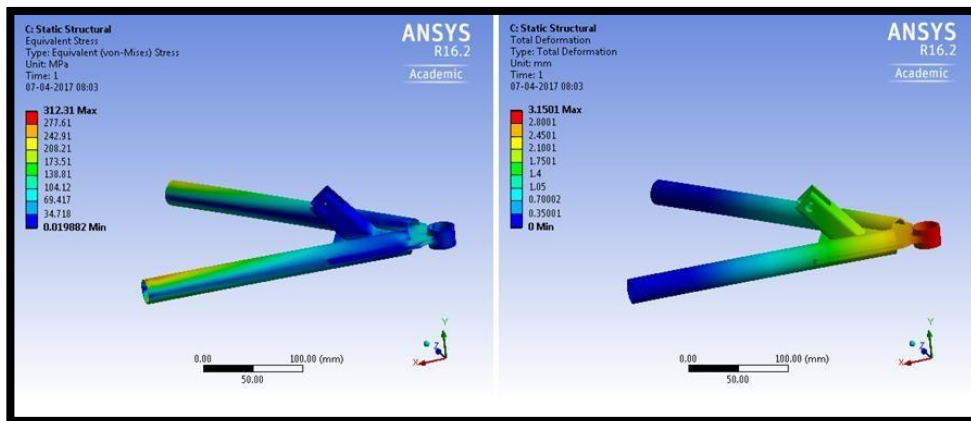

Figure 8: Static analysis of lower A-arm

Table 6: Summarized results from control arm analysis

Analysis results	Upper control arm	Lower control arm
Deformation	2.1602mm	3.1501
Von-mises stress	279Mpa	312Mpa
Factor of safety	1.64	1.47

VII. MATLAB VIBRATION RESPONSE

The mass-spring-damper depicted in Figure 1 is modelled by the second-order differential equation

$$m\ddot{x} + c\dot{x} + kx = F$$

where F is the force applied to the mass and x is the horizontal position of the mass.

mass and x is the horizontal position of

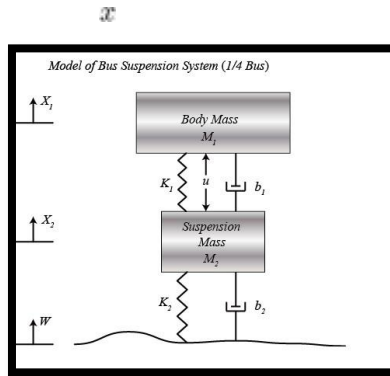

Figure 9: Model of suspension system

With the help of scope, step and PID controller in MATLAB the response is generated.

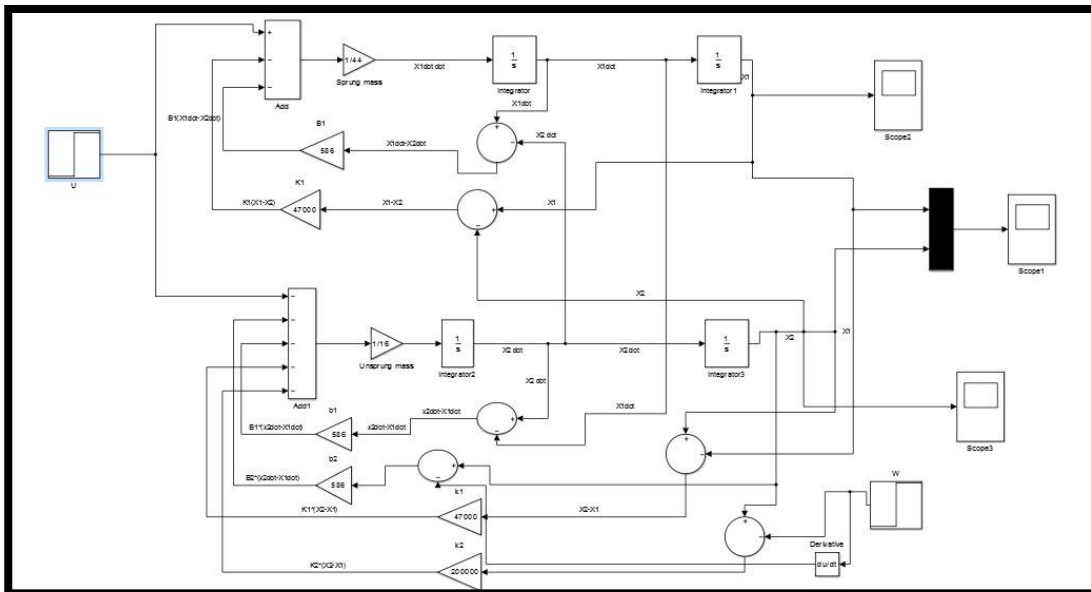

Figure 10: Matlab simulation of suspension system

International Journal of Innovative Research in Science, Engineering and Technology

An ISO 3297: 2007 Certified Organization

Volume 6, Special Issue 7, April 2017

5th National Conference on Trends in Automotive Parts Systems and Applications (TAPSA-2017)

30th & 31st March 2017

Organized by

Sri Krishna College of Engineering & Technology, Kuniamuthur, Coimbatore-641008, Tamilnadu, India

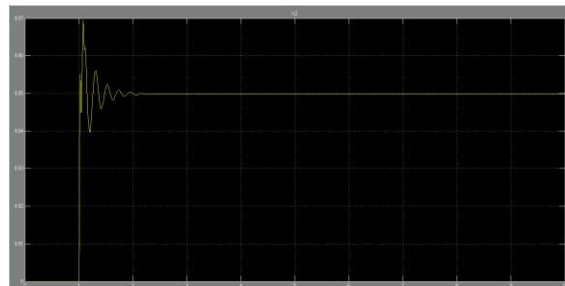

Figure 11: Response time curve

Thus the nominal response meets the response time requirement in the above graph.

VIII. RIDE AND ROLL ANALYSIS

For the purpose of Ride and Roll analysis in Multi Body Dynamics, we have used Hyper Works in our project. The graphs are plotted and the results generated are found to be appropriate.

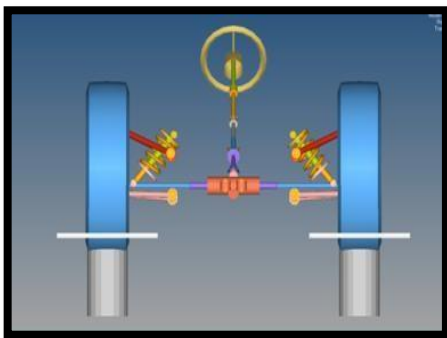

Figure 12: Ride analysis of our assembly

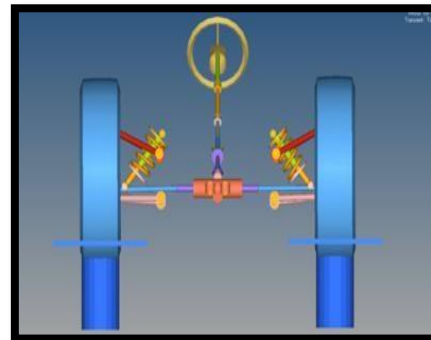

Figure 13: Roll analysis of our assembly

Graphs regarding ride analysis are:

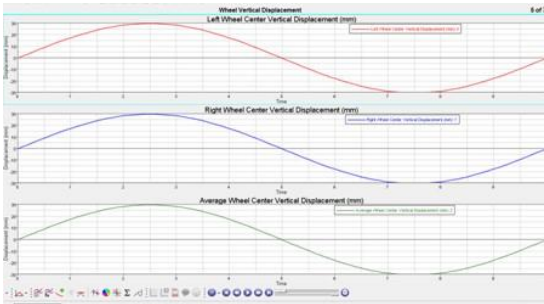

Figure 14: Wheel vertical displacement graph

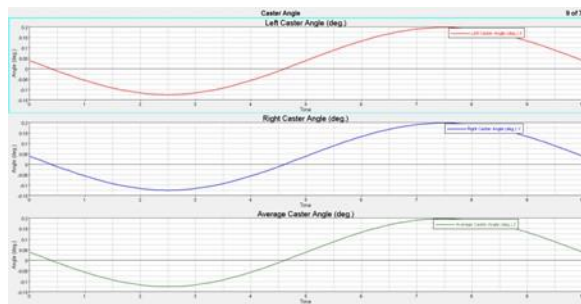

Figure 15: Caster angle vs Time

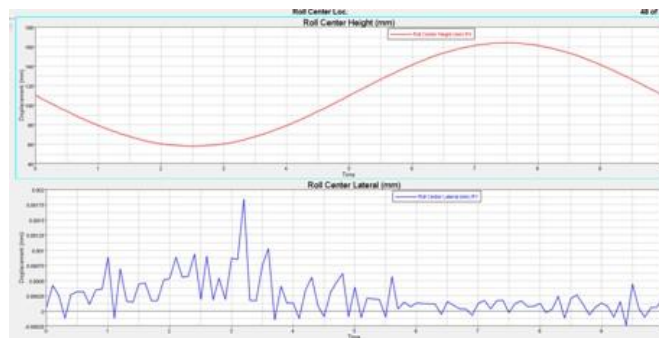

Figure 16: Roll centre height vs Displacement

Graphs regarding roll analysis are:

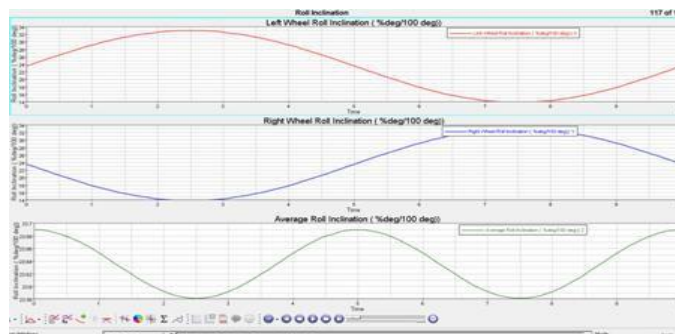

Figure 17: Roll inclination graph

International Journal of Innovative Research in Science, Engineering and Technology

An ISO 3297: 2007 Certified Organization

Volume 6, Special Issue 7, April 2017

5th National Conference on Trends in Automotive Parts Systems and Applications (TAPSA-2017)

30th & 31st March 2017

Organized by

Sri Krishna College of Engineering & Technology, Kuniamuthur, Coimbatore-641008, Tamilnadu, India

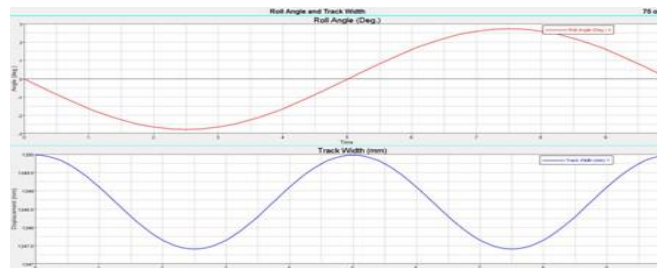

Figure 18 :Roll angle ,track width graph

IX.CONCLUSION

First the wheel base and track, camber and castor angles in the car is set and then the wheel and spring rates are calculated. Then with those values springs and control arms are designed and structural analysis is done in springs and control arms. Along with this modal analysis in the springs is performed. Then the response is generated in MATLAB and multi body dynamics is performed in hyper works and graphs are generated and are found to be smooth. Thus the design and analysis of suspension system is completed.

ACKNOWLEDGMENT

I would like to thank Professor Dr.N.Sangeetha and Assistant Professor Manikanda Prasath and HOD of our mechanical engineering department, Kumaraguru College Of Technology, Coimbatore for their valuable support to fine tune and develop this project.

REFERENCES

- [1] Race Car Vehicle Dynamics by William F. Milliken, Douglas L. Milliken
- [2] Bos P.C.M., "Design of a Formula Student Race Car Spring-Damper System", 0576519 CST2010.024
- [3] Gillespie T.D., "Fundamentals of Vehicle Dynamics", Society of Automotive Engineers.
- [4] <http://nptel.ac.in/courses/107106080/>
- [5] Bhandari. V. B., "Design of Machine Elements", 2010, TATA Mcgraw Hills.
- [6] Mr. Amit A.Hingane Prof. S. H. Sawant Prof.S.P.Chavan Prof. A.P.Shah, "Analysis of Semi active Suspension System with Bingham Model Subjected to Random Road Excitation Using MATLAB/Simulink", IOSR Journal of Mechanical and Civil Engineering (IOSRJMCE)
- [7] W. Jianyu, L. Yutao, and H. Xiangdong, "Optimization of double wishbone independent suspension for FSAE racing car", Machinery Design & Manufacture, vol. 10, pp. 120-2, 2011