

# Dehumidification of Atmospheric Air for Water Production

Vinay M V<sup>1</sup>, Suman A<sup>2</sup>, Shadakshari R<sup>3</sup>

U.G. Student, Department of Mechanical Engineering, Acharya Institute of Technology, Bangalore, Karnataka, India<sup>1,2</sup>

Asst Professor, Department of Mechanical Engineering, Acharya Institute of Technology, Bangalore, Karnataka, India<sup>3</sup>

**ABSTRACT:** An Atmospheric Water Generator is an appliance that employs dehumidification/condensing technology that extracts water from the humidity in the air. The water is then filtered and purified through several filters including carbon, and reverse osmosis, and UV sterilization lights. The result is pure drinking water from the air. An Atmospheric Water Generator works on the same principle as a refrigerators and air conditioners i.e. on the principle of cooling through evaporation. The Atmospheric water generator works by converting atmospheric air to pressurized air using a compressor and then this air is passed through condenser pipes which decreases its temperature to dew point. The air condenses to liquid and is passed through a filtration system and it is then stored in a tank. The major objective of our project is to provide safe and clean drinking water to those areas which are facing water shortage problems and where water transportation through regular means is expensive (especially rural areas). This project hopes to reduce the above mentioned problem by providing an atmospheric water generator that will run via bicycle-gear arrangement or stand-alone renewable source of energy i.e. either solar or wind.

**KEYWORDS:** Atmospheric water production, HVAC system, Dew Point Temperature, Relative Humidity.

## I. INTRODUCTION

The atmosphere contains water in the form of water vapour, moisture etc. Within that amount almost 35% of the water is wasted. This amount of water can be used with the help of an atmospheric water generator. This device is capable of converting atmospheric moisture directly into usable and even drinking water. The device uses the principle of latent heat to convert water vapour molecules into water droplets. In many countries like India, there are many places which are situated in temperate region; there are desert, rain forest areas and even flooded areas where atmospheric humidity is eminent. But resources of water are limited. In the past few years some projects have already been done to establish the concept of air condensation as well as generation of water.

So, this concept will be helping to extend the applications of such devices further in the near future. According to previous knowledge, we know that the temperature requires to condense water is known as dew point temperature. Here, the goal is to obtain that specific temperature practically or experimentally to condense water with the help of some electronics devices. This project consists of a bicycle-gear arrangement for running a condenser which is used to create the environment of water condensing temperature or dew point, indeed conventional compressor and evaporator system could also be used to condense water by simply exchanging the latent heat of coolant inside the evaporator. The condensed water will be collected to use for drinking purpose and various other uses.

## II. LITERATURE REVIEW

1. The first project was proposed by V. V. Tygarinov named as "An Equipment for Collecting Water from Air," in Russia, 1947 [2]. An apparatus consisting of a system of vertical and inclined channels in the earth to collect water from atmospheric air by cooling moist air to a temperature lower than its dew point has been proposed.
2. M. Hamed, "Absorption-Regeneration Cycle for Production of Water from Air-theoretical Approach"[1]. Description and analysis of the theoretical cycle for absorption of water vapour from air with subsequent regeneration, by heating is presented in first model. A theoretical limit for the maximum possible amount of water

# International Journal of Innovative Research in Science, Engineering and Technology

(A High Impact Factor, Monthly, Peer Reviewed Journal)

Visit: [www.ijirset.com](http://www.ijirset.com)

Vol. 7, Issue 4, April 2018

which can be collected from air using the desiccant through the absorption regeneration cycle at certain operating conditions of ambient parameters, heat to be added to the desiccant during regeneration and maximum available heating temperature could be evaluated through the analysis of this cycle.

3. A. M. Hamed "Application of Solar Energy for Recovery of Water from Atmospheric Air in Climatic Zones of Saudi Arabia."[3]
4. Alexander Bolonkin "Extraction of Freshwater and Energy from Atmosphere"[4]. Author offers and researches a new, cheap method for the extraction of freshwater from the Earth's atmosphere. The suggested method is fundamentally distinct from all existing methods that extract freshwater from air. All other industrial methods extract water from a saline water source (in most cases from seawater). This new method may be used at any point in the Earth except Polar Zones. It does not require long-distance freshwater transportation. If seawater is not utilized for increasing its productivity, this inexpensive new method is very environment-friendly.
5. EsamElsarrag "Experimental investigations on water recovery from the atmosphere in arid humid regions".[5] In this paper author propose the project in Gulf region which is one of the most arid regions in the world. The lack of water is considered as the most important problem. Annual rainfall is slight and erratic, with an annual average of 81 millimetres in Doha. As a result, renewable ground water resources are extremely limited and, in addition, there are problems with groundwater salinity. The atmosphere, endless source of water, contains a large quantity of water in the form of vapour in varying amounts especially in Gulf coastal region.
6. A. E. Kabeel "Application of sandy bed solar collector system for extraction of water from air".[6] In the present study the effect of using sandy bed solar collector system for extraction of water from air has been demonstrated. The sandy bed used to simulation of the Arab country desert condition.

## III. PROPOSED METHODOLOGY AND DISCUSSION

### • COMPONENTS AND DESCRIPTION

1. **Condenser:** A condenser is a device or unit used to condense a substance from its gaseous to its liquid state, by cooling it. In so doing, the latent heat is given up by the substance and will transfer to the condenser coolant. Condensers are typically heat exchangers which have various designs and come in many sizes ranging from rather small (hand-held) to very large industrial-scale units used in plant processes. For example, a refrigerator uses a condenser to get rid of heat extracted from the interior of the unit to the outside air. Condensers are used in air conditioning, industrial chemical processes such as distillation, steam power plants and other heat-exchange systems. Use of cooling water or surrounding air as the coolant is common in many condensers.
2. **Evaporator:** An evaporator is a device used to turn the liquid form of a chemical into its gaseous form. The liquid is evaporated, or vaporized, into a gas. An evaporator is used in an air-conditioning system to allow a compressed cooling chemical, such as R-22 (Freon) or R-410A, to evaporate from liquid to gas while absorbing heat in the process. It can also be used to remove water or other liquids from mixtures.
3. **Compressor:** A compressor is a mechanical device that increases the pressure of a gas by reducing its volume. An air compressor is a specific type of gas compressor. Most air compressors either are reciprocating piston type, rotary vane or rotary screw. Centrifugal compressors are common in very large applications. There are two main types of air compressor's pumps: oil-lubed and oil-less. The oil-less system has more technical development, but is more expensive, louder and lasts for less time than oil-lubed pumps. The oil-less system also delivers air of better quality.
4. **Blower:** An air blower is a device that converts power (using an electric motor, diesel or gasoline engine, etc.) into potential energy stored in pressurized air (i.e., compressed air). By one of several methods, an air compressor forces more and more air into a storage tank, increasing the pressure. When tank pressure reaches its upper limit the air compressor shuts off. The compressed air, then, is held in the tank until called into use. The energy contained in the compressed air can be used for a variety of applications, utilizing the kinetic energy of the air as it is released and the tank depressurizes. When tank pressure reaches its lower limit, the air compressor turns on again and re-pressurizes the tank.

## International Journal of Innovative Research in Science, Engineering and Technology

(A High Impact Factor, Monthly, Peer Reviewed Journal)

Visit: [www.ijirset.com](http://www.ijirset.com)

Vol. 7, Issue 4, April 2018

5. **Copper tube:** Copper tubing is most often used for supply of hot and cold tap water, and as refrigerant line in HVAC (Heating, ventilation, and air conditioning) systems. There are two basic types of copper tubing, soft copper and rigid copper. Copper tubing is joined using flare connection, compression connection, or solder. Copper offers a high level of corrosion resistance but is becoming very costly.

### IV. WORKING AND DESIGN

In a cooling atmospheric water generator, a compressor circulates refrigerant through a condenser and then an evaporator coil which cools the air surrounding it. This lowers the air temperature to its dew point, causing water to condense. A controlled-speed fan pushes filtered air over the coil. The resulting water is then passed into a holding tank with purification and filtration system to help keep the water pure and reduce the risk posed by viruses and bacteria which may be collected from the ambient air on the evaporator coil by the condensing water. The rate at which water can be produced depends on relative humidity and ambient air temperature and size of the compressor. Atmospheric water generators become more effective as relative humidity and air temperature increase. As a rule of thumb, cooling condensation atmospheric water generators to work efficiently when the temperature falls below  $-15^{\circ}\text{C}$ . This means they are relatively inefficient when located inside air-conditioned offices. The cost-effectiveness of an AWG depends on the capacity of the machine, local humidity and temperature conditions and the cost to power the unit. Water is often condensed from the air in the air conditioners when the ambient air is humid and hot in coastal tropical regions. This water can be conveniently used for drinking purpose.

The below CAD model represents the replica of the machine obtained and this model was done using the **Solid Works** Software.

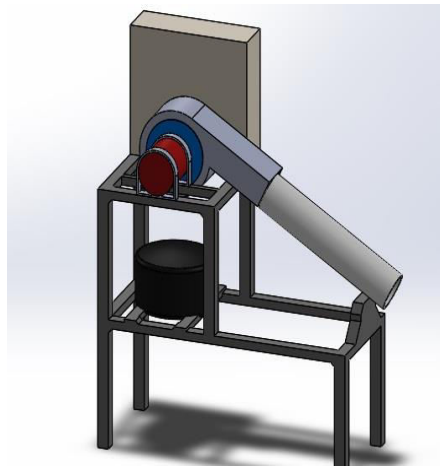

Fig 1: CAD model of the machine

### V. FACTORS AFFECTING THE PRODUCTION OF WATER

**Ambient air temperature:** As air temperature increases, the amount of moisture, i.e., water vapor, that the air can hold also increases. Thus, for increase in the air temperature decreases water production.

**Relative Humidity:** The amount of water vapour present in air expressed as a percentage of the amount needed for saturation at the same temperature is relative humidity. Thus, for increase in humidity increases water production.

**Size of compressor:** A compressor is a mechanical device that increases the pressure by reducing its volume. As the size of compressor increases the water production increases due to increase in coolant circulation rate.

# International Journal of Innovative Research in Science, Engineering and Technology

(A High Impact Factor, Monthly, Peer Reviewed Journal)

Visit: [www.ijirset.com](http://www.ijirset.com)

Vol. 7, Issue 4, April 2018

## VI. EXPERIMENTAL RESULTS

Many trials were conducted so as to check whether the production of water from the air using the machine fabricated. Once the production of water was seen, we measured the temperature, humidity and the quantity of water produced for different time intervals keeping the time of run as constant (i.e., 10 minutes).

The production of water was checked for different time intervals (Morning, Noon & night) in a particular day (i.e., on 24/04/18).

The below table consists of the data that were collected during the working of the machine.

TIME PERIOD	TEMPERATURE(°C)	HUMIDITY (%)	WATER PRODUCED (ml)
12:00 A.M	27.5	51	21
6:00 A.M	23.5	64	31.8
12:00 P.M	30.5	55	18
9:00 P.M	29	45	22.4

**Table 1: Data of the water produced at different intervals.**

A graph of water produced is plotted against the humidity of the air as shown. The amount of water vapour present in air expressed as a percentage of the amount needed for saturation at the same temperature is relative humidity. Thus, for increase in humidity increases water production.

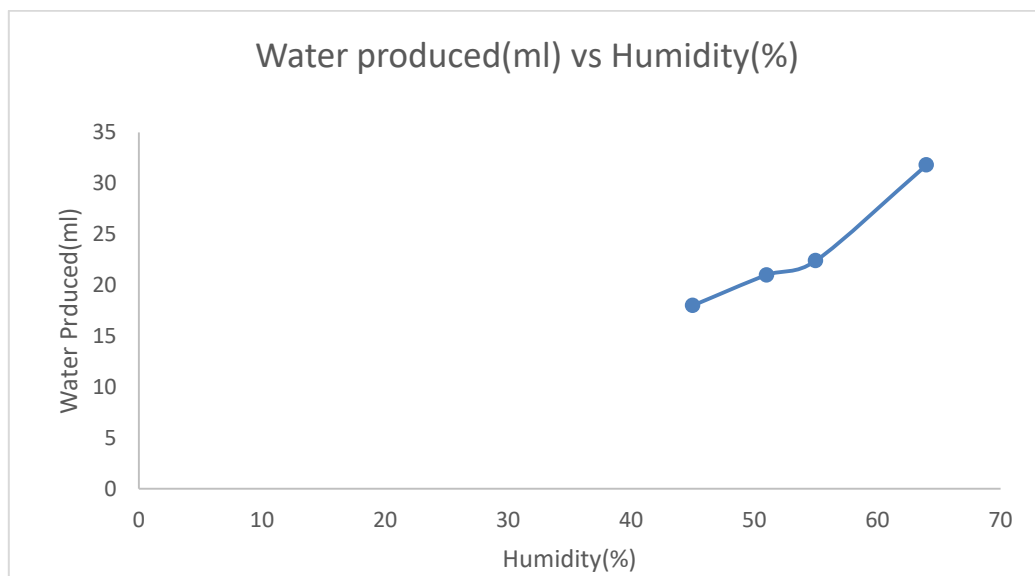

**Fig 3: Variation of water produced(ml) against Humidity(%)**

## International Journal of Innovative Research in Science, Engineering and Technology

(A High Impact Factor, Monthly, Peer Reviewed Journal)

Visit: [www.ijirset.com](http://www.ijirset.com)

Vol. 7, Issue 4, April 2018

A graph of water produced is plotted against the air temperature as shown. As air temperature increases, the amount of moisture, i.e., water vapour that the air can hold also increases. Thus, for increase in the air temperature decreases water production.

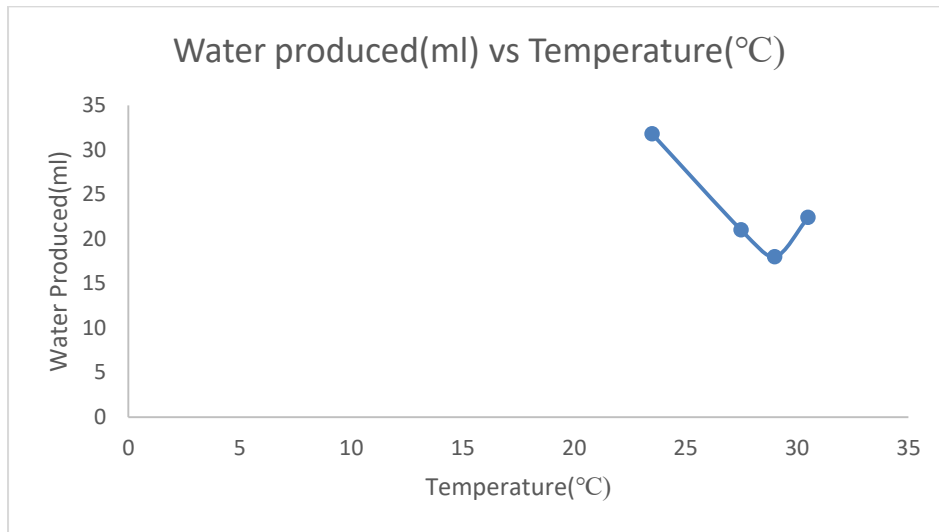

**Fig 4: Variation of water produced (ml) against Temperature (°C)**

The below graph represents the bar graph of the water produced at different time intervals (Morning, Noon & night) in a particular day (i.e., on 24/04/18).

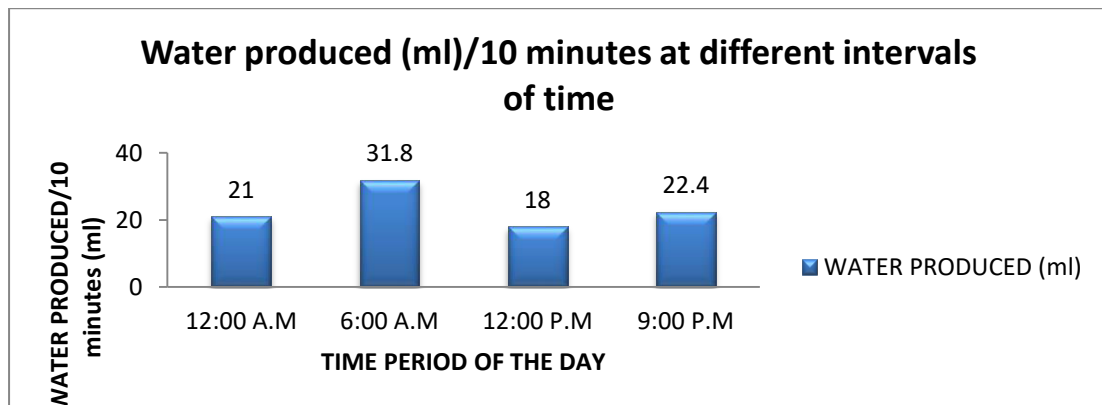

**Fig 5: Variation of water produced(ml) at different time intervals**

The water produced was tested for different properties such as hardness, alkalinity, pH value, iron content etc.. As per IS 10500:2012(second revision) the measured values for the above mentioned properties are within the standard and hence the water produced is potable.

# International Journal of Innovative Research in Science, Engineering and Technology

(A High Impact Factor, Monthly, Peer Reviewed Journal)

Visit: [www.ijirset.com](http://www.ijirset.com)

Vol. 7, Issue 4, April 2018

## VII. ADVANTAGES

1. Highly portable, economical and easy to maintain
2. No expensive piping infrastructure investment is needed
3. Quick flexible deployment
4. No conventional water source required
5. Needs only to plug into electrical socket to generate fresh, pure water
6. Convenient, dependable, and safe
7. Gives you total control over your water needs

## VIII. APPLICATIONS

1. The AWG has distinct uses and applications in specific locations, circumstances and immediate needs. It can be considered a logistical asset due to the nature of its mobility and durability. Its reliability, due to the fact that it needs only two factors to produce drinking water - air and electricity, makes it a worthwhile investment.
2. Restaurants, bars, and hotels that need copious amounts of clean water and ice will find the AWG essential in the kitchen or lobby premises. Office environments that are using bottled water units can do away with plastics when replaced by AWG. AWG can be considered at remote locations, island resorts, mining sites, and instances where water scaling is an issue.
3. In cases of natural disasters and epidemics, the availability of AWGs can be timely in saving lives and improving sanitary conditions. Disaster management organizations specify drinking water as a top priority to maintain good health; the portability, reliability of AWGs in generating pure drinking water will prove to be a vital technological intervention in sustaining lives and health.

## IX. CONCLUSION

By applying this concept to a densely humid region we can extract more amount of water from atmosphere. The design is more convenient for water collection. The design is so simple such that the device can be carried to anywhere. The equipment is very helpful for explorers, mountaineer's fishermen etc. An atmospheric water generator may be also run via bicycle-gear arrangement or stand-alone renewable source of energy i.e. either solar or wind.

## REFERENCES

1. A. M. Hamed, "Absorption-Regeneration Cycle for Production of Water from Air-theoretical Approach."(1999) Vol. 19, No. 4, 2000.
2. V. V. Tygarinov, "An Equipment for Collecting Water from Air," Patent No. 69751, Russia, (1947).
3. A. M. Hamed, "Application of Solar Energy for Recovery of Water from Atmospheric Air in Climatic Zones of Saudi Arabia." doi:10.4236/nr.2011.21002 Published Online March 2011
4. Alexander Bolonkin "Extraction of Freshwater and Energy from Atmosphere"
5. EsamElsarrag "Experimental investigations on water recovery from the atmosphere in arid humid regions". CIBSE Technical Symposium, DeMontfort University, Leicestern UK – 6th and 7th September 2011
6. A. E. Kabeel "Application of sandy bed solar collector system for extraction of water from air". Eighth International Water Technology Conference, IWTC8 2004
7. M. Kobayashi, "A method of obtaining water in arid land, Solar Energy" 7 (1963), 93-99.
8. A. Sultan, "Absorption/regeneration non-conventional system for water extraction from atmospheric air, Renewable Energy" 29 (2004), 1515-1535.
9. R. C. Hall, "Production of water from the atmosphere by absorption with subsequent recovery in a solar still, Solar Energy" 10 (1966), 42-45.
10. H. E. Gad, A. M. Hamed and I. EL-Sharkawy, "Application of a solar desiccant/collector system for water recovery from atmospheric air, Renewable Energy" 22 (2001), 451-556.
11. Y. Alayli, N. E. Hadji and J. Leblond, "A new process for the extraction of water from air", (1987), 227-229.
12. A. M. Hamed, "Non-conventional method for collecting water from air using solar energy", Ph.D. Thesis, Russian Academy of Science, 1993.
13. N. P. Clarke and C. Calif, Atmospheric water extractor and method, United States Patent 5,233,843, 1993.
14. A. M. Hamed, "Parametric study of the adsorption-desorption system producing water from ambient air", International Journal of Renewable Energy Engineering 2 (2000), 244-252.
15. A. Khalil, "Dehumidification of atmospheric air as a potential source of fresh water in" the UAE, Desalination 93 (1993), 587-596.
16. B. A. Habeebullah, Potential use of evaporator coils for water extraction in hot and humid areas, Desalination 237 (2009), 330-345.
17. R. V. Wahlgren, Atmospheric water vapour processor designs for potable water production: a review, Water Resources Management 35 (2001), 1-22.