

# **SVC and STATCOM for Reactive Power Compensation in Transmission Line**

Priyanka G Patel<sup>1</sup>, Gaurang Patel<sup>2</sup>, Dr. Ami T. Patel<sup>3</sup>

P.G. Student, Department of Electrical Engineering, MGITER Engineering College, Navsari, Gujarat, India<sup>1</sup>

Assistant Professor, Department of Electrical Engineering, MGITER Engineering College, Navsari, Gujarat, India<sup>2</sup>

Assistant Professor, Department of Electrical Engineering, Government Engineering College, Bharuch, Gujarat, India<sup>3</sup>

**ABSTRACT:** This research study focus on the comparative analysis of reactive power compensation technologies. Static VAR Compensator (SVC) is one of the shunt connected FACTS device which is to be utilized here for the purpose of reactive power compensation. A Static Synchronous Compensator (STATCOM) is used to improve the voltage profile of the load bus.

**KEYWORDS:** facts devices, reactive power compensation, svc, statcom.

## **I. INTRODUCTION**

Reactive power compensation is a means for realizing the goal of a qualitative and reliable electrical power system. Reactive power compensation is a technique for the compensation of the unwanted effects of reactive loads which makes the power factor less than unity. With the reactive power compensation techniques, reactive power is controlled in such a way that the performance of electric power system such as improvement of transmission efficiency, harmonic loss reduction and power quality improvement gets improved.

There are two viewpoints to the issue of reactive power remuneration: load remuneration and voltage support. Load remuneration comprises of change in force component, adjusting of genuine force taken from the supply, good voltage regulation, and so on of extensive changing burdens. Voltage bolster comprises of decrease of voltage change in a transmission line. These types compensation can be realized in two ways: series and shunt compensation. These adjust the parameters of the framework to give improved VAR compensation. Shunt compensation is one where capacitors are employed in parallel with the transmission line and act like a synchronous condenser and absorb or supply reactive power. A series is one where inductor or capacitors are employed in series to supply required power. Mostly shunt compensation are employed nowadays in FACT devices.

## **II. RELATED WORK**

### **Synchronous Phase Modifier**

This is an ideal source having the capacity either to absorb or inject reactive power. However, it has got number of limitations as pointed out in section 1.5 (performance requirement). There are proven alternative methods of compensation available which are practically equivalent to SPM at low cost, more reliable, fast in response and giving trouble free service.

### **Shunt Capacitors**

The use of shunt capacitors in conventional way through mechanical switches has the following:

- Overall cost is very low.
- The installation is simple requiring no strong foundations.
- Incur negligible losses
- Less maintenance problems
- More reliable in service with long life. However, notable short coming are:

# International Journal of Innovative Research in Science, Engineering and Technology

(A High Impact Factor, Monthly, Peer Reviewed Journal)

Visit: [www.ijirset.com](http://www.ijirset.com)

Vol. 7, Issue 5, May 2018

- Not possible to vary reactive power matching with load demand continuously (only step variation).
- There exist a possibility for harmonics, if present, to get amplified.
- There also exists a scope for series / parallel resonance phenomenon to occur, which requires to be investigated prior hand. Hence the choice of a suitable compensator scheme calls for detailed study and careful design before implementation.

### Series Capacitors

it poses serious problems during faults, prone for resonance phenomenon, complexity in control and likely to give rise to sub-synchronous oscillations. Hence the series capacitors can be installed after careful study only. They are employed widely in HV lines and somewhat uneconomical for distribution networks, as the requirements in both cases differ widely.

### III. FACTS DEVICES

Flexible AC Transmission (FACT) devices are static equipments which helps in not only for compensating reactive power but also control one or more AC transmission parameters. Flexible AC Transmission Devices includes Static synchronous compensator, Thyristor switched reactor, Static synchronous series compensator, Thyristor switched capacitor, Thyristor switched series reactor.

Depending on the power electronic devices used in power system, the FACTS controllers can be classified as

- Variable impedance type.
- Voltage Source Converter (VSC).

Variable impedance controllers include:

- Static Var Compensator (SVC), (shunt connected)
- Thyristor Controlled Series Capacitor or compensator (TCSC), (series connected)
- Thyristor Controlled Phase Shifting Transformer (TCPST)
- PST (combined shunt and series)

The VSC based FACTS controllers are:

- Static synchronous Compensator (STATCOM) (shunt connected)
- Static Synchronous Series Compensator (SSSC) (series connected)
- Interline Power Flow Controller (IPFC) (combined series-series)
- Unified Power Flow Controller (UPFC) (combined shunt-series)

### IV. SVC CONTROLLER

The two main popular configuratin of this type of shunt controller are the fixed capacitor (FC) with a thyristor controlled reactor (TCR) and the thyristor switched capacitor (TSC). In its simplest form, the SVC consists of a TCR in parallel with a bank of capacitors. From an operational kind, the SVC behaves like a shunt-connected variable reactance, which can generates or absorbs reactive power in order to regulate the voltage magnitude at the point of connection to the AC network.

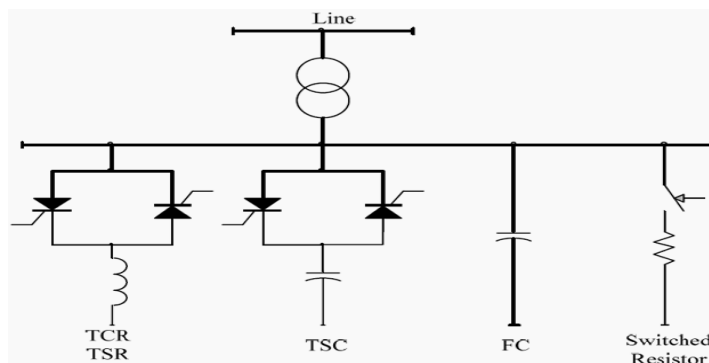

Fig 1:Statcom controller

# International Journal of Innovative Research in Science, Engineering and Technology

(A High Impact Factor, Monthly, Peer Reviewed Journal)

Visit: [www.ijirset.com](http://www.ijirset.com)

Vol. 7, Issue 5, May 2018

A static synchronous compensator (STATCOM), also known as a "static synchronous condenser" ("STATCON"), is a regulating mechanism used on alternating current electricity transmission networks. It is based on the power electronics voltage-source converter and can act as either a source or sink of reactive AC power to an electricity network. If it is connected to a source of power it can also provide active AC power. That is a member of the FACTS family of devices.

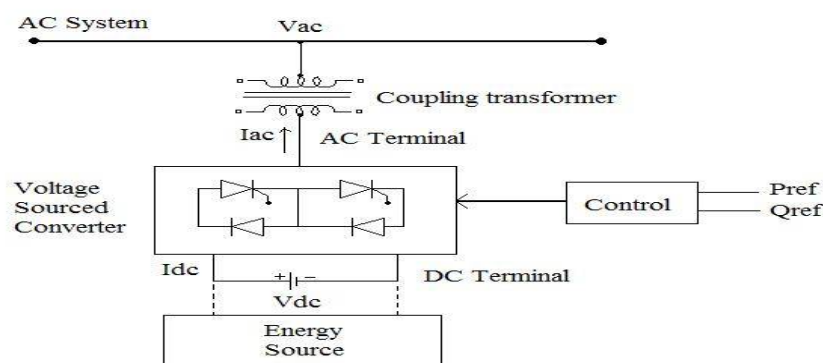

fig 2: statcom controller

## V. V-I CHARACTERISTIC OF SVC AND STATCOM

The operating Principle of both the FACT Devices are different, both of the devices are used for the improvement of power system stability. Fig shows the operating characteristics of both the FACT Devices the STATCOM has the capability to maintain the full capacitive current even at low system voltage while the SVC has the absent of same characteristics. This ability make the STATCOM more effective than the SVC in the improvement of power system stability.

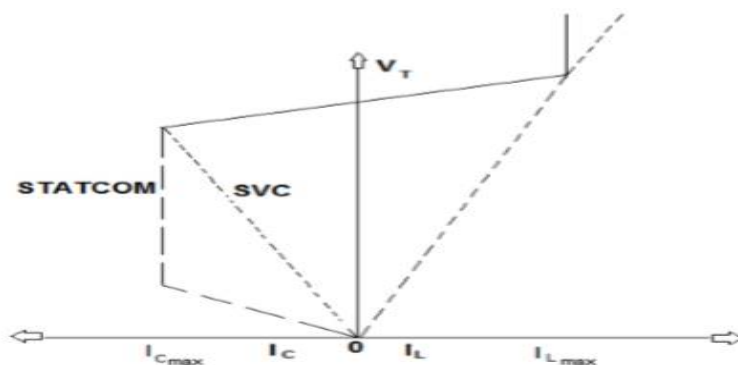

Fig 3: v-i characteristic of svc and statcom

## VI. MATHEMATICAL FORMULATION

Static Synchronous Compensator is one of the static component device and comes under the family of FACTS devices. It can absorb or supply reactive power in the single or three phase AC systems. A transmission network reactive power can be compensated using Static Synchronous Compensator. It also helps in preventing fluctuations in the transmission system like sudden voltage increase (voltage sag), sudden voltage decrease (voltage sag), transients etc.

A STATCOM comprises of a three phase inverter utilizing SCRs, MOSFETs or IGBTs, a DC capacitor (which when charging will absorb reactive power and while discharging will supply reactive power), a connection reactor whose purpose is to link the inverter output to the AC supply side, channel parts to channel out the high recurrence segments

# International Journal of Innovative Research in Science, Engineering and Technology

(A High Impact Factor, Monthly, Peer Reviewed Journal)

Visit: [www.ijirset.com](http://www.ijirset.com)

Vol. 7, Issue 5, May 2018

because of the PWM inverter. From the DC side capacitor, a three stage voltage is produced by the inverter. This is synchronized with the AC supply. The connection inductor interfaces this voltage to the AC supply side. This is the essential standard of operation of STATCOM.

$$p = V_{\max} I_{\max} \cos \omega t \cos(\omega t - \theta)$$

$$p = \frac{V_{\max} I_{\max}}{2} \cos \theta (1 + \cos 2\omega t) + \frac{V_{\max} I_{\max}}{2} \sin \theta \sin 2\omega t$$

The reactive power can be represented by:

$$\frac{V_{\max} I_{\max}}{2} \sin \theta \sin 2\omega t$$

Where: P= Instantaneous Power  
Vmax=Maximum Voltage  
Imax=Maximum Current  
W=Angular Frequency  
T=Time period  
Θ=Angle between Voltage and Current

## VII. RESULT & DISCUSSION

A static var compensator (SVC) is used to regulate voltage on a system. When system voltage is low the SVC generates reactive power (SVC capacitive). When system voltage is high it absorbs reactive power (SVC inductive). km transmission line is used.

A positive value of SVC susceptance indicates that the SVC is capacitive and a negative value indicates inductive operation.

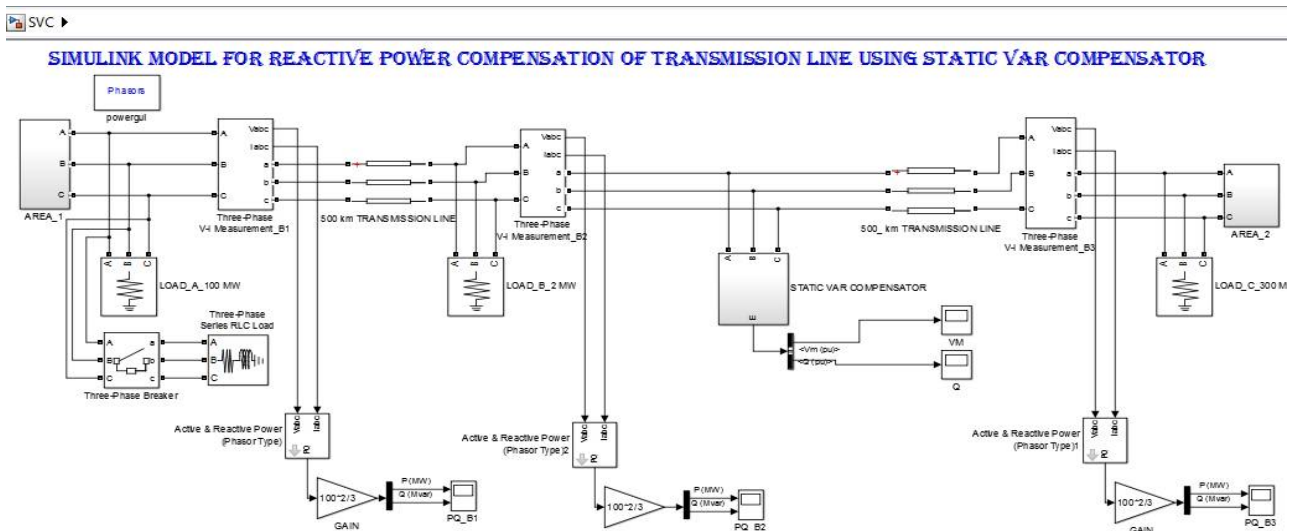

Fig 4 :simulation with svc

The SVC is rated +100 Mvar capacitive and 50 Mvar inductive. The two 500 kV Three-Phase Programmable Voltage Source is used to vary the system voltage to observe the SVC performance. The SVC is set in voltage regulation mode

# International Journal of Innovative Research in Science, Engineering and Technology

(A High Impact Factor, Monthly, Peer Reviewed Journal)

Visit: [www.ijirset.com](http://www.ijirset.com)

Vol. 7, Issue 5, May 2018

with a reference voltage  $V_{ref}=1.0$  pu. The voltage droop is  $0.03$  pu/100MVA, so that the voltage varies from  $0.97$  pu to  $1.015$ pu when the SVC current goes from fully capacitive to fully inductive.

## SIMULINK MODEL FOR REACTIVE POWER COMPENSATION OF TRANSMISSION LINE USING STATCOM

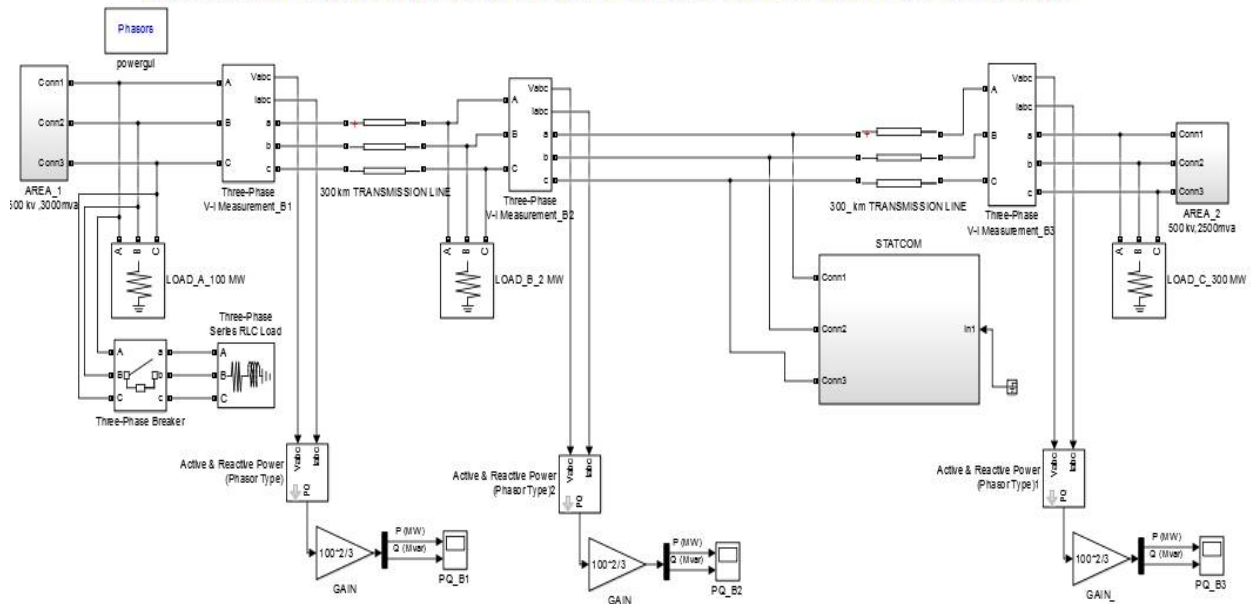

fig 5: simulation model for statcom

## VIII. SIMULATION RESULT WITH SVC & STATCOM

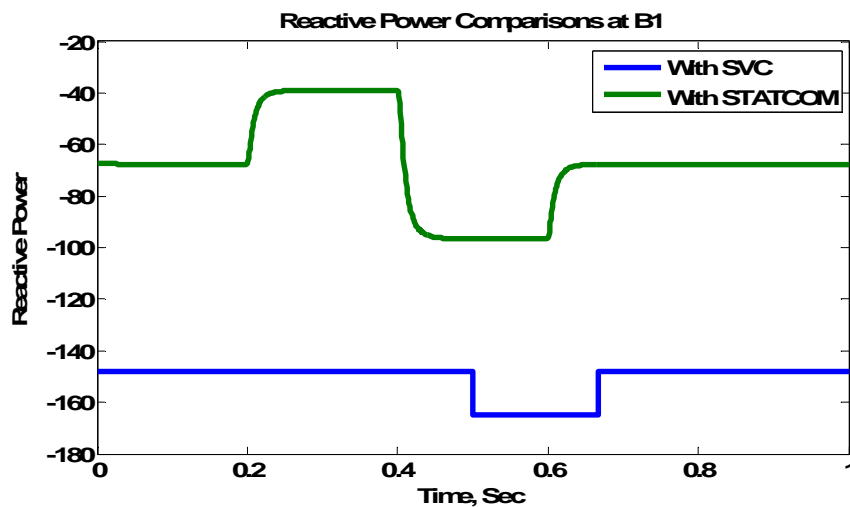

fig 6: reactive power waveform at b1

Initially the source is generating nominal voltage. Then, voltage is successively decreased ( $0.97$  pu), increased ( $1.018$ pu) and finally returned to nominal voltage ( $1$  pu). A positive of  $Q$ (pu) value indicates inductive operation and a negative value of  $Q$ (pu) value indicates capacitive operation.

# International Journal of Innovative Research in Science, Engineering and Technology

(A High Impact Factor, Monthly, Peer Reviewed Journal)

Visit: [www.ijirset.com](http://www.ijirset.com)

Vol. 7, Issue 5, May 2018

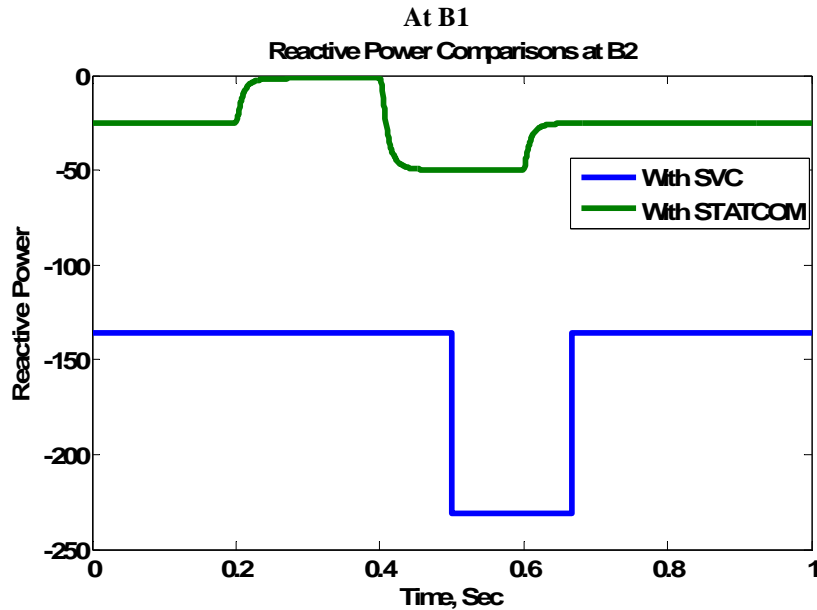

Fig 7: reactive power waveform at b2

During the 10-cycle fault, a key difference between the SVC and the STATCOM may be observed. The reactive power is generated by the SVC is -0.48 pu and the reactive power generated by the STATCOM is -0.71 pu.

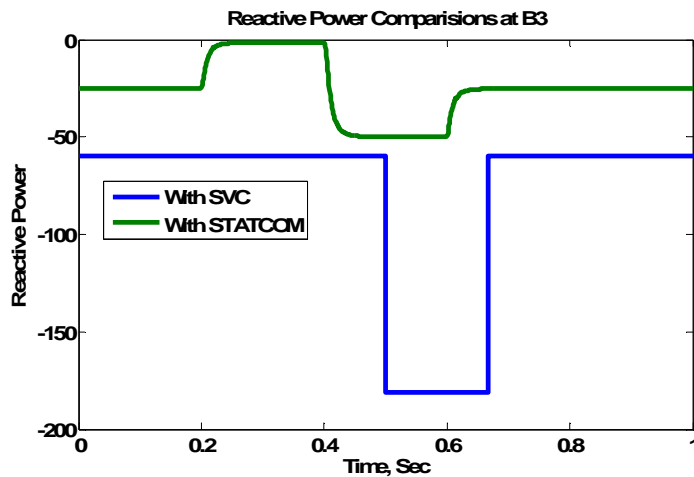

Fig 8: reactive power at b3

## IX. CONCLUSION

Run the simulation and look at results. Result displays the measured reactive power  $Q_m$  generated by the SVC (magenta trace) and the STATCOM. During the 10-cycle fault, a key difference between the SVC and the STATCOM may be observed. The reactive power is generated by the SVC is -0.48 pu and the reactive power generated by the STATCOM is -0.71 pu.

# International Journal of Innovative Research in Science, Engineering and Technology

(A High Impact Factor, Monthly, Peer Reviewed Journal)

Visit: [www.ijirset.com](http://www.ijirset.com)

Vol. 7, Issue 5, May 2018

We can then see that the maximum capacitive power generated by a SVC is proportional to the square of the system voltage while the maximum capacitive power generated by a STATCOM decreases linearly with voltage decrease (constant current). This ability to provide more capacitive power during a fault is one important advantage of the STATCOM over the SVC. Moreover, the STATCOM will normally exhibit a faster response than the SVC because of the presence of Voltage Source Converter.

## APPENDIX

### SVC DATA:

Converter rating : 100 MVA  
System nominal voltage: 500 KV  
Reactive power limits:  $Q_c(\text{var}>0)= 100 \text{ Mvar}$   
Reactive power limits:  $Q_l(\text{var}<0)= -100 \text{ Mvar}$   
Average time delay due to thyristor valves firing  $T_d : 4 \text{ ms}$

### STATCOM :

Converter rating : 100 MVA  
System nominal voltage: 500 KV  
Converter impedance:  $R= 0.0073 \text{ pu}$   $L= 0.22 \text{ pu}$   
Converter initial current: Magnitude=0 pu Phase angle =0 deg  
DC link nominal voltage : 40 KV  
DC link equivalent capacitance : 375 Uf

## REFERENCES

- [1] M.Gerald Geafori Titus, "Reactive Power Compensation using STATCOM for single phase distribution system ", 2015 International Conference on Circuit, Power and Computing Technologies, ICCPCT-2015
- [2] Mohammed Benidris, Samer Sulaeman, "Reactive Power Compensation for Reliability Improvement of Power Systems", IEEE Transactions, 2016
- [3] Famous. O. Igbinoia, Ghaeth Fandi, Jan Švec, Zdenek Müller, Josef Tlustý, "Comparative Review of Reactive Power Compensation Technologies", IEEE Transactions, 2015
- [4] Piyushkumar M. Saradva, Mahesh H. Pandya, "Reactive and Real Power Compensation in Distribution Line using D-STATCOM with Energy Storage", 2016 International Conference on Computation of Power, Energy Information and Communication (ICPEIC), IEEE
- [5] Brij Sunder Joshi, Om Prakash Mahela, Sheesh Ram Ola, "Reactive Power Flow Control Using Static VAR Compensator to Improve Voltage Stability in Transmission System ", IEEE International Conference on Recent Advances and Innovations in Engineering (TCRAIE-2016), December 23-25, 2016, Jaipur, India
- [6] Ahmed H. Al-Mubarak; Muhammad Haris Khan, Moayed Z. Al-Kadhem, "Dynamic Reactive Power Compensation For Voltage Support Using Static Var Compensator (SVC) In Saudi", IEEE Transactions, 2015
- [7] S.K.Das and J.K.Moharana, "Design, Analysis and Simulation of Small Signal Control Strategy of a STATCOM for Reactive Power Compensation on Variation of DC link Voltage", 2013 International Conference on Power, Energy and Control (ICPEC)
- [8] Hui Li, Shuai Li, Hao Zhang, "Study of STATCOM on Reactive Power Compensation Strategy of Wind Farm", 2013 International Conference on Computer Sciences and Applications
- [9] Tang Aihong, Guo Fang, Liu Furong, Chen Yuepeng, "Mathematical model of STATCOM based on switched System", IEEE Transactions, 2011
- [10] A. K. Pathak, Dr. M. P. Sharma, Dr. Manoj Gupta, "Modeling and Simulation of SVC for Reactive Power Control in High Penetration Wind Power system", IEEE INDICON 2015