

Coin Shortage Reduction Using NFC Card Digital Payment System

Dr. Hemalatha K.L.¹, VinayM², Sujith Manjunath³

Professor, Department of ISE, SKIT, Bangalore, Karnataka, India¹

UG Students, Department of ISE, SKIT, Bangalore, Karnataka, India^{2,3}

ABSTRACT:Recently, individuals experience the effects of coin deficiency issue and tend to charge the sum and round off to the closest different of 10 in spots, for example, in eateries, retail shops, private transports, and markets all around. This project proposes a development arrangement called byte-coin, to tackle the coin deficiency issue that we are looking in our nation. The exchange includes the support of the retailer and client. Despite the fact that there is no immediate contact with the bank at the season of exchange a base investment of bank is important to effectively execute this. The utilization of web is disregarded. Every exchange includes the investment of both retailer and client.

KEYWORDS: *NFC payment, byte-coin*

I. INTRODUCTION

India has an issue with little change, lodging, eateries, auto-taxi drivers, retail shop, open transports, advertises wherever individuals experience the effects of coin shortage issue and tend to charge the sum adjusted to the closest multiples of 10. RBI supplies billions of coins each year in different divisions all over India. Yet at the same time the basic man faces deficiency of progress and regularly being paid in eclairs, mints and so on. This project proposes an innovative arrangement called byte-coin, to take care of the coin lack issue that we are looking in our nation. The arrangement included a secured computerized installment framework that has reason constructed restricts on the sum engaged with the exchange. Every exchange includes the investment of the retailer and client. In spite of the fact that there is no immediate contact with the bank at the season of exchange a base support of the bank is important to effectively execute this. There is no need of a web association in this manner making it open to all aspects of our nation. There are two sides to this extend. Byte coin card on the client side and byte coin gadgets on the retailer or businessperson side. the client needs to have an affirmed byte coin card. Each retailer or businessperson should possess a byte coin gadgets. Byte coin exchange works safely finished correspondence. Every exchange is called as coin exchange. It has a couple of fundamental reason assembled confinements. Each card can hold a most extreme of 200rs as it were. every gadget has a most extreme day by day point of confinement of 20000rs. any single coin exchange can just exchange a sum between 1 to 9rs. The reader has a double display screen the retailer side one is a GUI in light of touch screen TFT show compose though the client centered one is illustrations show type. Both the display shows on brilliant in demonstrating just the relevant data as per the viewer. Retailer side card shows the current balance.

II. LITERATURE SURVEY

S. W. Park and I. Y. Lee, the following method uses the combination of mobile and NFC aroused great momentum for activation of NFC service as a payment service and is expected to go commercially in both domestic and global. Therefore, further enhances with a signature RTD-based transaction authentication method was used to protect personal financial information.

N. E Madhoun, F. Guenane, and G. Pujolle, it describes NFC technology, where NFC transaction is used in simple and practical way. EMV security is a feature, which describes it as a security protocol for both contact and contactless payment system. The two main security constraints between a customer payment device and payment terminal: 1) mutual authentication 2) confidentiality of sensitive data.

13th-14th March 2018

Organized by

Departments of Computer Science & Information Science Engineering, Sri Krishna Institute of Technology, Bangalore, India

C. A. Tucker, U. Muehlmann, and M.Gebhart, this method uses wireless energy transmission for key element in contactless HF communication technology, such as radio frequency or NFC. So, they propose a novel computational model to reveal the dynamic of energy transfer can be shown as set of force used by the oscillator at the interface of free- space. Finally, high frequency finite-element simulation based model is used to solve a practical problem. They have proposed theoretical concepts and frame conditions to improve the NFC solution development process supported by an experimental setup.

A. Mandalapu clarified the adaptable utilization of credit and charge card exchanges has turned out to be progressively omnipresent thus have the related vulnerabilities that make them a typical focus for cybercriminals. Besides, a common complexity related with obstructing of ATM cards includes dreary intelligent procedures and even perhaps long holding up times amid association with client mind administrations. Utilizing a three factor confirmation conspire utilizing NFC (Close Field Communication: a rising innovation developed from a mix of contact-less recognizable proof and interconnection giving information trade), Dash Matrix Calculation and One-time secret word, we depict and evaluate the possibility to defeat regular exchange liabilities (brute force attack, shoulder surfing, skimming of ATM cards). The helper highlight of blocking ATM cards is actualized utilizing a QR code verification plot and NFC innovation, executed both in NFC empowered telephones furthermore, non-NFC telephones.

III. PROPOSED SYSTEM

This project proposes an innovative arrangement called BYTE-COIN, to take care of the coin shortage issue that we are looking in our nation. The arrangement included a secured computerized installment framework that has reason constructed restricts on the sum associated with the exchange. Every exchange includes the cooperation of the retailer and the client. In spite of the fact that there is no immediate contact with the bank at the season of exchange, a minimum participation of banks is important to effectively execute this. There is no need of web association in this manner making it available to all aspects of the nation.

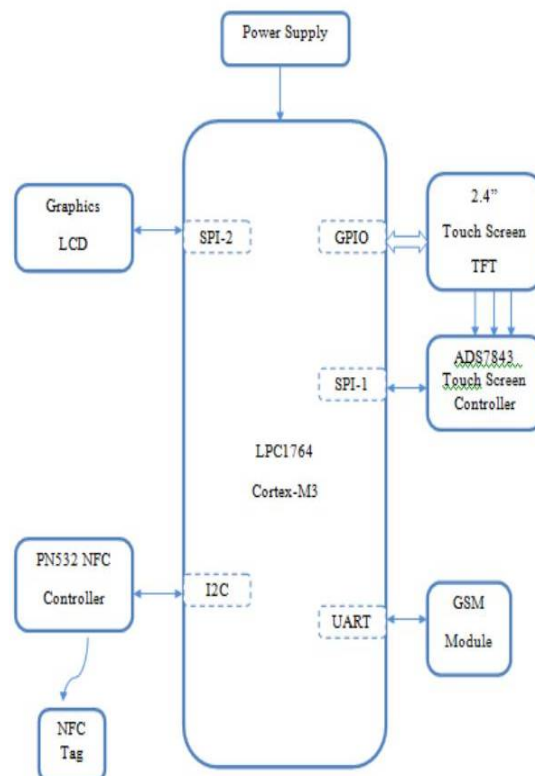

Figure 3.1: Block diagram of byte-coin

3.1 NEAR FIELD COMMUNICATION

The whole installment process is carried through NFC, which is a protected and general contactless correspondence innovation developed from RFID. It works in the 13.56MHz radio recurrence band and the correspondence regularly

occurs at 10 cm or lesser separation. Along these lines the exchange happens when the two gadgets are at closeness to each other. A NFC controller from NXP semiconductor is utilized for this reason. The cards utilized as a part of this venture are standard Type-A NFC labels. In spite of the fact that we have not utilized, the as of late presented NTAG Type 2 NFC cards offer much predominant security systems for a task this way.

- Short extend contactless innovation
 - Limited to 10cm territory
 - Very high security
 - 13.56 MHz recurrence
 - 106 to 424 Kbps information rate
 - Low cost and low power than Bluetooth or Wi-Fi

3.2 THIN FILM TRANSISTOR

Thin-Film Transistor is a matrix of pixels and ITO region and the TFT device is called array. Collection of pixels together create an image on the display. A TFT-LCD array consist of controllers, power supply, and driver circuits.

3.3 ARM CORTEX-M3

The ARM cortex– M3 processor is the business 32-bit processor for exceedingly deterministic ongoing application and has been particularly created to empower accomplices to grow superior exhibitions ease stages for an expansive scope of gadgets which incorporates microcontrollers, car body sytems, mechanical control sytems and remote sytems administration and sensors. The processor is exceptionally configurable empowering an extensive variety of usage from those requiring memory security and capable follow innovation through to amazingly cost gadgets requiring insignificant area.

3.4 POWER SUPPLY

A power supply gives a steady yield paying little mind to voltage variety "settled" three-terminal direct regulator are generally accessible to produce settled voltage of plus 3v, and give or take 5v,9v,12v, or 15v when the heap is not exactly around 7 amperes.

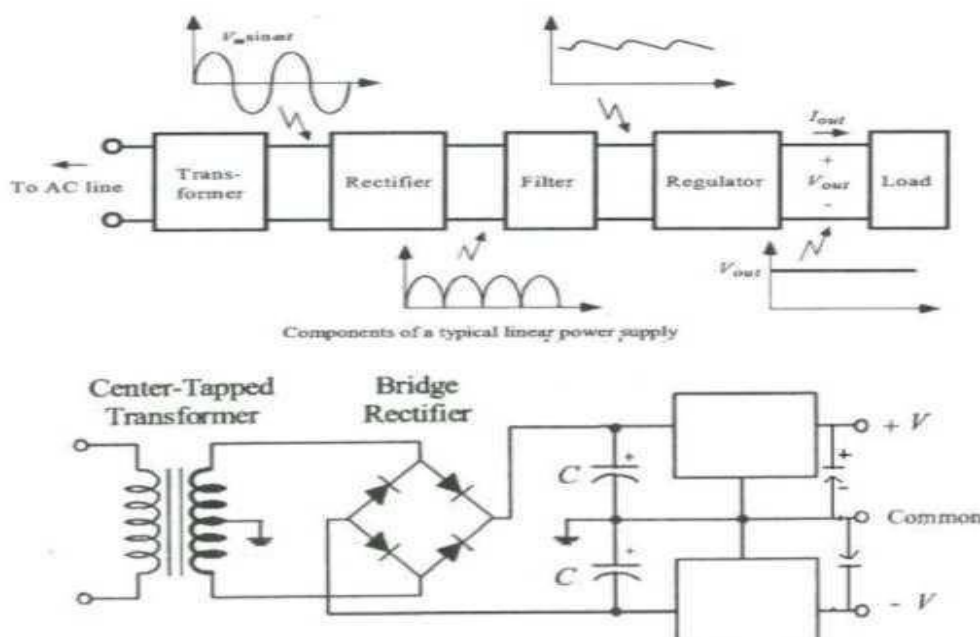

Figure 3.2: Schematic diagram of basic power supply

- *Output current up to 1A
- *Short circuit protection
- *Thermal overload protection
- *Output voltages of 5, 6,8,9,10,12,15,18,24

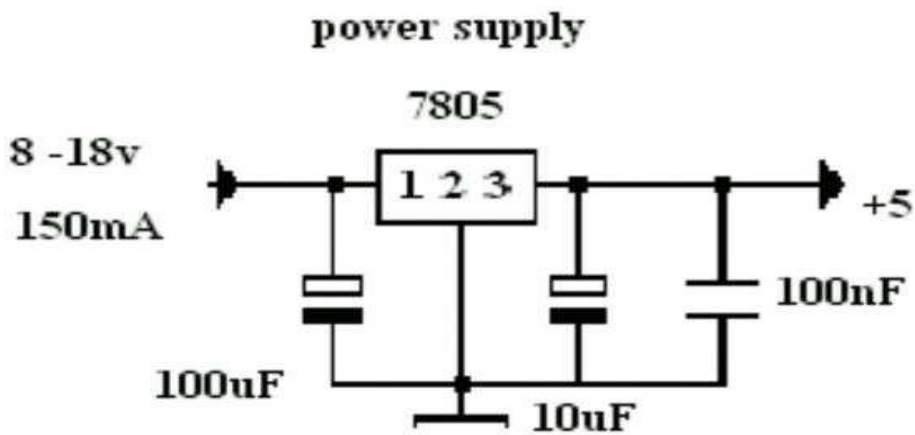

Figure 3.3: Circuit diagram of power supply

This circuit is a little +5V control supply, which is valuable while trying different things with computerized gadgets. Little economical divider transformers with variable yield voltage are accessible from any hardware shop and general store. Those transformers are effortlessly accessible, yet normally their voltage direction is extremely poor, which makes at that point not exceptionally usable for computerized circuit experimenter unless a superior control can be accomplished somehow. The accompanying circuit is the response to the issue. This circuit can give +5V yield at around 150 mA current, yet it can be expanded to 1 A when decent cooling is added to 7805 controller chip. The circuit has over-burden and terminal assurance.



Figure 3.4: Hardware implementation of byte coin

13th-14th March 2018

Organized by

Departments of Computer Science & Information Science Engineering, Sri Krishna Institute of Technology, Bangalore, India

IV. CONCLUSION

This paper, consists no link with bank. But also contain some link with bank and the device is issued by bank authorities after testing and approval, a bank can maintain the user database both the device owner and card owner. This will make the maintenance process an easier one. In this work, a data processing secure protocol and a certificate per NDEF message are proposed for NFC systems to provide extra security.

REFERENCES

- [1] S. W. Park, and I. Y. Lee, "Transaction Authentication Scheme Based on Enhanced Signature RTD for NFC Payment Service Environments" IEEE International Conference on Platform Technology and Service (PlatCon), pp. 1-4, 2016.
- [2] J. Wu, C. Zhao, Z. Lin, J. Du, J. Hu and X. He, "Wireless Power and Data Transfer via a Common Inductive Link Using Frequency Division Multiplexing" IEEE Transactions on Industrial Electronics, Vol. 62, No. 12, pp. 7810-7819, 2015.
- [3] C. A. Tucker, U. Muehlmann, and M. Gebhart, "Contactless power transmission for NFC antennas in credit-card size format. IET Circuits, Devices & Systems" IET Circuits, Devices & Systems, 2016.
- [4] W. Lumpkins and M. Joyce, "Near-Field Communication: It pays", IEEE Consumer Electronic Magazine, pp. 49-53, 2015.
- [5] D. M. Monteiro, J. J. Rodrigues and J. Lloret, "A secure NFC application for credit transfer among mobile phones" IEEE International Conference on Computer, Information and Telecommunication Systems (CITS), pp. 1-5, 2012.
- [6] Y. Zhao, B. Mahoney, and J.R. Smith, "Analysis of a Near Field Communication wireless power system", IEEE Conference on Wireless Power Transfer Conference (WPTC), pp. 1-4, 2016.
- [7] N. El Madhoun, F. Guenane, and G. Pujolle, "A cloud-based secure authentication protocol for contactless-NFC payment. In Cloud Networking (CloudNet)" IEEE 4th International Conference on pp. 328-330, 2015.