

International Journal of Innovative Research in Science, Engineering and Technology

(A High Impact Factor, Monthly, Peer Reviewed Journal)

Visit: www.ijirset.com

Vol. 7, Issue 9, September 2018

Semi-automation of Fitting Electric Motor into a Fuel Dispenser

Karthick L¹, Giri Haran S², Arun B², Gughan R P², Jeevanandham B³

Assistant Professor, Department of Mechanical Engineering, Hindusthan College of Engineering and Technology,
Coimbatore, Tamil Nadu, India¹

B.E. (Mechanical Engineering) Graduate, Sri Shakthi Institute of Engineering & Technology, Coimbatore,
Tamil Nadu, India²

U.G. Student, B.E. (Mechanical Engineering), Hindusthan College of Engineering and Technology, Coimbatore,
Tamil Nadu, India³

ABSTRACT: An assembly unit was in need of decreasing labour and increasing productivity, especially in the motor fitting section of its industry. A semi-automatic retractable scissor lift was designed and fabricated in order to speed up the fitting of electric motor and reduce the waiting time of dispensers in the queue. With this semi-automation, production is improved upto 12%. Total time taken for the motor fitting cycle is reduced by one third. 16 man hours is reduced to 6 man hours in the motor fitting section. Total cost of the project is Rs.31490.00 with the payback period of 4.45 months.

KEYWORDS: Productivity, semi-automatic retractable scissor lift, motor fitting cycle, man hours and payback period.

I. INTRODUCTION

Various activities of assembly unit were studied using the methods suggested by different authors [9&12] to locate the areas wherein production cost can be reduced. It was found that motor fitting was the activity wherein the waiting time of dispensers was tremendously high, affecting the total productivity. Factors like people and equipment constraints [3] that cause this bottle neck were analysed. In order to reduce the cost of production, it was aimed to design and fabricate a mechanical system which could increase the productivity and decrease labour in the motor fitting section of the assembly unit.

II. RELATED WORK

Ghazi Abu Taher et al. [8] published a paper in International Journal of Scientific and Research Publications about automation of material handling using conveyors. His works is hinted as follows: Belt Conveyor system is used in material transport in foundry shop like supply and distribution of molding sand, molds and removal of waste. His paper is based on the combination of Belt and Bucket Conveyers to perform complex task within a short time and successfully in a cost-effective way. In combination with computer-controlled pallet handling equipment this allows for more efficient retail, wholesale, and manufacturing distribution. It is considered a labour-saving system that allows large volumes to move rapidly through a process, allowing companies to ship or receive higher volumes with smaller storage space and with less labour expense.

Automated pick and place mechanisms were developed by 1954 itself. George Devol [7] applied for the first robotics patents in 1954 and granted in 1961 with publication number US2988237 A. The first company to produce a robot was Unimation, founded by Devol and Joseph F. Engelberger, and was based on Devol's original patents. They used hydraulic actuators and were programmed in joint coordinates, i.e. the angles of the various joints were stored during

International Journal of Innovative Research in Science, Engineering and Technology

(A High Impact Factor, Monthly, Peer Reviewed Journal)

Visit: www.ijirset.com

Vol. 7, Issue 9, September 2018

a teaching phase and replayed in operation. Owing to high cost, it is not advisable to go for a completely automated system. Hence, pneumatic semi-automatic system was proposed, as a solution to the assembly unit.

III.SEMI-AUTOMATIC RETRACTABLE SCISSOR LIFT

Various automated systems like chain conveyor [1], belt and bucket conveyors [8] and pick and place robots [7], used in the industry were studied. Kinematics of the equipment was decided based on the availability of space in the industry and study of various simple mechanisms [12]. Though, precision is not good in pneumatic cylinders due to the compressibility of gasses [5], pneumatics was decided to be used as it is readily available in the industry. Industrial automation systems were studied [13]. Owing to high costing, semi-automation was decided to be used. 3D modelling was done using Solidworks 2015 software. The isometric view of semi-automatic retractable scissor lift is shown in the figure 1. Figure clearly shows 3 kinds of motion in the semi-automatic retractable scissor lift, that are: one translatory motion along the piston rod axis of cylinder P, another translator motion along vertical axis & third translator motion along the piston rod axis of cylinder R. In addition to the components shown in the figure, the design consists of pneumatic cylinders, slider, slider holder, scissor lift, trolley, guide wheels, rail, electronic kit, proximity sensor, solenoid valve and flow control valves.

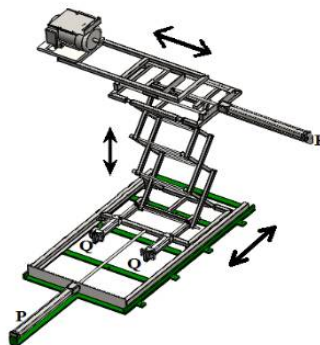

Fig. 1. Semi-automatic retractable scissor lift

3.1.Design

The design of various links and the selection of pneumatic cylinders are explained in the following sub-chapters.

3.1.1. Moment balancing and frictional resistance calculation

Force and moment balancing was done [6]. Friction [14] was calculated using the formula (1) and (2).

$$\text{Rolling resistance offered by wheel in N} = \frac{Cmg}{2} = 112.5 \text{ N} \quad (1)$$

Where, C = 0.5 which is coefficient of rolling resistance, m is mass of the semi-automatic scissor lift in kg and g = 10 m/s² which is acceleration due to gravity. Rolling resistance for cylinder Q will be zero as there is no rolling wheels for cylinder Q. Frictional resistance is given by,

$$\text{Frictional resistance offered for cylinder R in N} = Cmgk \quad (2)$$

Where, k = 0.6 is length ratio. Frictional resistance offered for cylinder R using equation (2) for fitting is 97.5N and return is 40.8 N.

3.1.2. Force and pressure calculations

$$\text{Force acted on cylinder P in N} \quad F_p = m \frac{d}{t^2} + R \quad (3)$$

Where, m is the mass of the semi-automatic scissor in kg, d is the distance travelled in m, t is the time taken to move to the distance d and R is rolling resistance in N. There are 3 classes of dispensers, namely, class A, B and C. Using equation (3), for class A, forces for fitting $F_{p,F}$ and return $F_{p,R}$ are found to 180.660 N and 117.56 N respectively.

$$\text{Force acted on cylinder Q in N} \quad F_Q = mg + \frac{m1}{t^2} \quad (4)$$

International Journal of Innovative Research in Science, Engineering and Technology

(A High Impact Factor, Monthly, Peer Reviewed Journal)

Visit: www.ijirset.com

Vol. 7, Issue 9, September 2018

Using equation (3), for class A, 598.02 N and 328.21 N are the forces for fitting F_{Q-F} and return F_{Q-R} respectively.

$$\text{Force acted on cylinder R in N} \quad F_R = \frac{mg}{t^2} + R \quad (5)$$

From (5), for class A, forces in cylinder R are estimated as $F_{R-F} = 598.02$ N (fitting) and $F_{R-R} = 328.21$ N (return).

3.1.3. Selection of pneumatic cylinders

Cross sectional area of the cylinders P, Q and R are 254.34mm^2 , 706.5mm^2 and 254.34mm^2 respectively.

$$\text{Pressure inside the cylinder P and R in bar} \quad P_{P \text{ and } R} = \frac{F}{A} \quad (6)$$

Where F is the Force acted by the cylinder in N and A is the area of the cylinder in mm^2 . From (6), pressure inside the cylinder P and R for fitting and return are found to be $P_{P-F \text{ and } R-F} = 7.103$ bar and $P_{P-R \text{ and } R-R} = 4.622$ bar respectively.

$$\text{Pressure inside the cylinder Q in bar} \quad P_Q = \frac{F}{2A} \quad (7)$$

For class A, by (7), pressure values in cylinder Q are $P_{Q-F} = 4.232$ bar and $P_{Q-R} = 2.322$ bar. Based on the above calculations, by considering stroke length required and standard pneumatic cylinder available in the market [4&10], suitable pneumatic cylinders were chosen.

3.1.4. Air flow rate estimation

$$\text{Air flow rate in the cylinder} \quad = \frac{lA}{t} \text{ mm}^3/\text{s} \quad (8)$$

Where l is the stroke length in mm, A is the cross-sectional area of cylinder and t is the time in s. Using (8), air flow rate is estimated as 10404.818, 28613.205, 23959.565, 91845.00, 6888.375 and 18369.00 in cylinders P (fitting and return), Q (fitting and return) and R (fitting and return) respectively. Calculation was done in the similar way for the three classes by varying pressure and air flow rate to provide flexibility to the motor fixing unit.

3.1.5. Analysis

Various links were analyzed using Von-Mises theory and their fatigue life was calculated using ANSYS R15.0. Linkages were designed with the help of standard designing procedures [2]. It is inferred from the Von-mises stress analysis in figure 2, that no stress concentration takes place in the slide, with maximum stress acting in slide estimated to be 1.5478×10^8 Pa, which occurs at the middle portion; hence a support is added in the middle to keep both the legs from tearing apart, as a result of buckling. The safety factor analysis in fig. 2 shows that, the minimum factor of safety for the slider is 1.93, which is safe enough for this working environment where human interventions are minimal. Its fatigue analysis was carried out and its life was estimated as 5000 days. Similarly, various elements of the mechanical system are analyzed.

International Journal of Innovative Research in Science, Engineering and Technology

(A High Impact Factor, Monthly, Peer Reviewed Journal)

Visit: www.ijirset.com

Vol. 7, Issue 9, September 2018

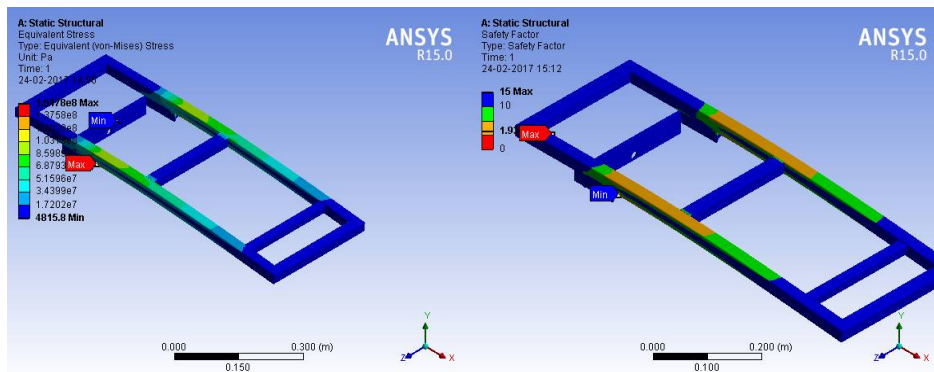

Fig. 2. Analysis of slider

IV. WORKING

Initially, the fixture is moved to the position near the motor table. The semi-automatic scissor lift consists of a vertical rod with 4 sensing points which is here denoted as Q1, Q2, Q3 and Q4, a horizontal rod with 4 sensing points namely R1, R2, R3 & R4 and 2 L shaped sensing points in the main frame which is named here as P1 and P2. Worker places the motor on the fixture. At once, scissor lift starts to move vertically downwards to Q2 in the vertical rod by the contraction of pneumatic cylinder Q. From there, by the contraction of pneumatic cylinder P, trolley moves so that the fixture is moved to P2. Afterwards, by the extension of the pneumatic cylinder R, the slider 1 slides horizontally to the position R2 in the horizontal rod to get close to the deo frame. Then vertically downward motion happens to the point Q4. It, then slides horizontally to the sensible position R3 by extension of the cylinder R. Then cylinder Q lifts the fixture vertically upwards to Q3 in the vertical rod which is exactly straight to the motor location. Then it slides to the position R4 horizontally. At this position, the motor's base plate fixes into the deo frame exactly. Then, the fixture returns back to its origin position by traversing the previously mentioned cycle in the reverse direction.

V. TRIAL INFERENCES

It was found that from the study of various activities that motor fitting was also the bottle neck since it allowed dispenser to wait for some time before it was being processed by it. To increase the productivity, actual time (processing time + waiting time) 101s needed to be reduced by increasing the capacity. Crashing down the time to 92 s (table 1) might increase the productivity, yet, motor fitting would still be the bottle neck. So, by reducing time of motor fitting to 66 s or less would make it a non-bottleneck activity. Similarly, total time is estimated for other 2 classes of dispensers. There is increase in productivity in all the three classes of fuel dispensers. Due to semi-automation, there is 6.67%, 12% and 4.44% increase in productivity of classes A, B and C respectively. Total cost of the semi-automatic scissor lift is Rs. 31,490.00 with the payback period of 4.45 months. Hence, 22.4% of total investment will be taken back in the form of savings every month.

VI. CONCLUSION

Bottle neck in the motor fitting section was removed with the help of fabricated semi-automatic retractable scissor lift. There is 6.67%, 12% and 4.44% increase in productivity of classes A, B and C respectively. Total productivity can be improved further by removing other bottle necks such as pump fitting and deo frame assembly in the respective classes of fuel dispensers. It is clearly evident that the automation of industry is becoming a necessity in this modern competitive environment to survive in this globalized market. The assembly unit is also concerned about the necessity of industrial automation.

International Journal of Innovative Research in Science, Engineering and Technology

(A High Impact Factor, Monthly, Peer Reviewed Journal)

Visit: www.ijirset.com

Vol. 7, Issue 9, September 2018

REFERENCES

- [1] Ali K. Gunal Shigeru Sadakane and Edward J. Williams, "Conveyors and Their Equipment Interfaces. Auto Simulations Symposium '96", Mountain Rendezvous Proceedings, pp. 313-319, 1996.
- [2] Bhandari V.B., "Design of Machine Elements", Tata McGraw-Hill Publications, 2010.
- [3] Binod Timilsina, "Removing Bottleneck from a Manufacturing Unit", Thesis: Central Ostrobothnia University of Applied Sciences, 2012.
- [4] Brian S. Elliott, "Compressed Air Operations Manual", McGraw Hill Book Company, 2006.
- [5] Cheng, "Design and Control for the Pneumatic Cylinder Precision Positioning Under Vertical Loading. Guidance, Navigation and control conference", Reston, 2005
- [6] Ferdinand P. Beer, Russell Johnston E., Jr. John T. Dewolf and David F. Mazurek, "Mechanics of Materials", McGraw-Hill publications, 6th edition, pp. 4, 2012.
- [7] George Devol, "Programmed Article Transfer", United States Patent Publication number US2988237 A, 1961.
- [8] Ghazi Abu Taher, Yousuf Howlader, Md. Asheke Rabbi and Fahim Ahmed Touqir, "Automation of Material Handling with Bucket Elevator and Belt Conveyor", International Journal of Scientific and Research Publications, 2014.
- [9] John Kamauff, "Manager's guide to Operations Management", McGraw Hill Publications, 2010.
- [10] "Parker cylinder- Hydraulic and Pneumatic Cylinder Engineering Data", Parker cylinder, U.S.A., 2005.
- [11] Rama Murthy, "P. Operations Research", New Age International (P) Limited Publishers, 2007.
- [12] Ratan S.S., "Theory of machines", Tata McGraw Hill Publications, 3rd edition, 2012.
- [13] Shell R., "Handbook of Industrial Automation", New York: Marcel Dekker, Inc., pp. 46, 2000.
- [14] Timoshenko S., Young D.H. and Rao J.V., "Engineering Mechanics", Mc Graw Hill Publications, 1964.