

Improving Security Performance Based on Intra-Body Communication Using Body Area Network

Ramineni Rakesh¹, Telugunta Mounika², Mogasala Jagan Subash³

Assistant Professor, Department of Electronics and Communication Engineering, Usha Rama College of Engineering and Technology, Telaprolu, Vijayawada, India¹

U.G. Student, Department of Electronics and Communication Engineering, Sri Prakash College of Engineering, Govari Konaru, Tuni, India²

U.G. Student, Department of Electronics and Communication Engineering, Sri Prakash College of Engineering, Govari Konaru, Tuni, India³

ABSTRACT: Improving security performance by using Body Area Network to control the door locks which uses Surface electrodes and microcontroller. The rapid increase in healthcare demand has seen novel developments in health monitoring technologies, such as the body area networks (BAN). BAN technology envisions a network of continuously operating sensors, which measure critical physical and physiological parameters e.g., mobility, heart rate, and glucose levels.

KEYWORDS: Body Area Network (BAN), electrical properties, galvanic coupling, human body tissues, intra body communication (IBC), modelling, radio frequency (RF), transceiver design, wireless communication.

I. INTRODUCTION

The current paradigm in healthcare is the notion of continuous remote patient monitoring using a network of wireless sensors. These healthcare sensor network systems, consisting of body area networks (BAN) and infrastructure area networks avoid the need for a manual self-administered health system and may enable users to take control of their health disorders in the future. BAN technology envisions miniaturized sensors worn or implanted on the body, continuously monitoring health parameters and acting to prevent the onset of critical health events. For example, diabetics now have access to an automatic insulin pump which monitors glucose levels and administers insulin when glucose levels are high. Similar technologies will one day result in devices which can minimize incidences of heart attack or stroke. They could prevent frequent hospital visits and save costs for both the individual patient and a nation's healthcare system. According to a recent report from Parks Associates, the U.S. market for wireless home-based healthcare applications and services will expand with an annual growth rate of over 180% and become a \$4.4 billion industry in 2013.

Statistics such as these indicate a rising demand for portable health monitoring devices e.g., BANs, which are recurrently Undergoing tremendous research and development.

At the heart of BAN technology is the need for short-range data read communications, both from sensors to a decision maker (usually a hub node) or from the hub node to an actuator, e.g., insulin delivery system. Wireless data communications based on radio frequency (RF) have been successfully developed using popular protocols such as

International Journal of Innovative Research in Science, Engineering and Technology

(A High Impact Factor, Monthly, Peer Reviewed Journal)

Visit: www.ijirset.com

Vol. 8, Issue 7, July 2019

Bluetooth, ZigBee, and ANT.

II. RELATED WORK

A major drawback of wireless RF propagation for miniaturized medical portable monitoring devices is the high-power consumption which limits the practical duration of an operation. Most current research claim that ZigBee and ANT have a battery life of three years, but this is at a low operating data rate, e.g., 1 B transmitted per 5 min. The IEEE 802.15.4 standard for low power ZigBee protocol indicates a transmission power output of 0 dBm (1 mW). Continuous operation at the maximum data rate of 250 kb/s generally consumes a normal Lithium ion battery in a matter of hours. It is evident that new approaches to ultralow power wireless technology are required for improving next generation BAN technology. Mirhojjat seyedi, Behailu Kibret, Daniel t. H. Lai, Michael Faulkner proposed the securities and issues of Intrabody communication [1].

A. Securities of the IBC:

The IBC system is a protected and private communication network which provides natural security and interference free Communication. The required operating frequency of IBC is much lower compared to RF systems. This means signals are confined to the person's proximity since reading data requires body contact. There is no signal leakage through the skin in IBC method and environmental noise has less effect on communication [3]. At higher frequencies (300 MHz to several gigahertz), the signal wavelength becomes comparable to the Human body channel length and body radiates energy acting as an antenna (dipole antenna). Since transmitter and receiver contain small size electrodes (for example Neuroline electrodes active area is 54 mm²) instead of antennas, the larger wavelength of the carrier signal compared to the electrode size results in interference-free IBC below 300MHz's.

B. Energy Consumption:

The key issue with RF propagation in portable devices is that it consumes battery life quickly. For example, ZigBee has the maximum data rate of 250 kb/s at 26.5 mW resulting in 106 nJ per received bit [4]. The energy consumption of UWB is 2.5 nJ/b when data rate was 16.7 Mb/s. Bae et al. Recently demonstrated that IBC consumes an order of magnitude less energy (0.24 nJ/b) at data rates up to 10 Mb/s which makes it an attractive communications method for WBAN applications.

III. PROPOSED SYSTEM

The proposed system is used to improve the security using bio signals to access the door. It uses surface electrodes, microcontrollers and driver circuit. The data from the controller is converted to the electrical signal by using a driver circuit. The resultant signal is allowed to transmit through the body using surface electrodes. Another electrode is placed at different place of the body. It collects the input from the body and feeds the driver circuit. Driver and signal inducing circuit converts the electrical signal to binarized input. The binarized input feeds the controller and accelerator sensor detects the character and it sends the command to the driver circuit. Depending upon the controller's commands, door will be locked/unlocked using driver circuit.

IV. BLOCK DIAGRAM

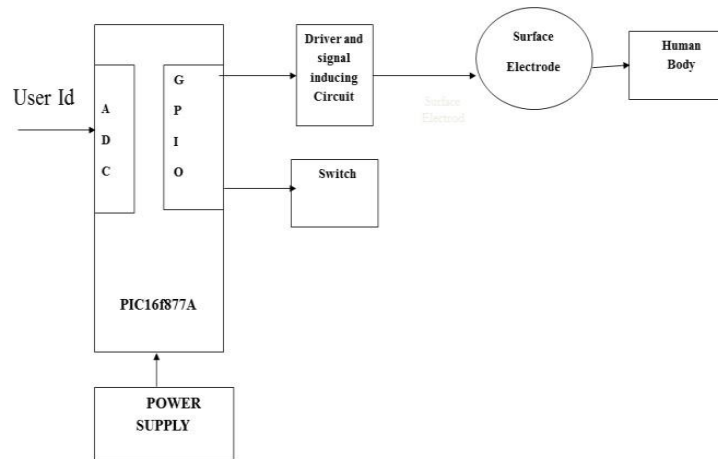

Fig.1. Hardware Architecture of the proposed system Transmitter

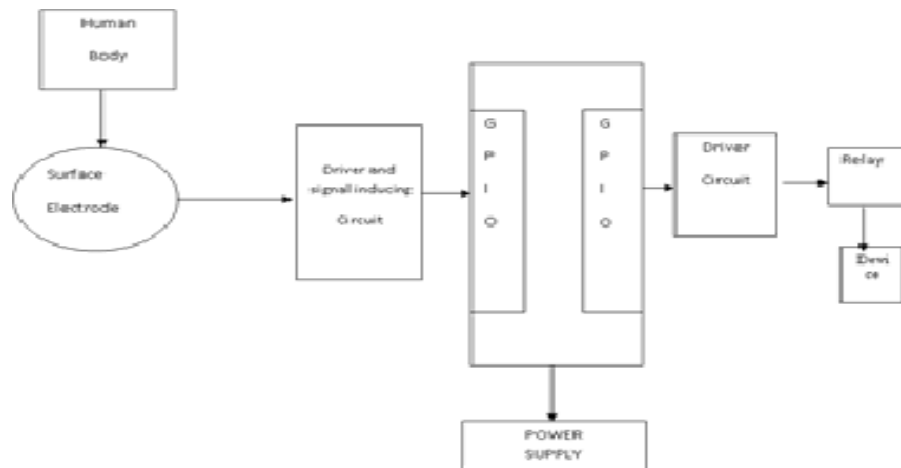

Fig.3. Hardware Architecture of the proposed system Receiver

The system consists of two nodes such as transmitter and receiver node. The transmitter part consists of microcontroller, driver circuit, switches and electrode. The data are transmitted to the driver circuit by pressing the switch. Then the data is transmitted through the human body by surface electrodes. Switches which are interfaced with the microcontroller are used to start up the operation of transmission of data. The receiver part consists of microcontroller, driver circuit, relay and devices. This part is used to receive data from the human body by the surface electrodes. The data is received by the microcontroller using driver circuit. Depend upon the data from the micro controller; driver circuit will switch off/on the motor by using the relay. In general IBC can be classified into two basic coupling types (i.e., how the electrical signals are transmitted) capacitive coupling (electric field) and the galvanic coupling (waveguide). Illustrates schematically the two different types of IBC coupling. For both coupling

International Journal of Innovative Research in Science, Engineering and Technology

(A High Impact Factor, Monthly, Peer Reviewed Journal)

Visit: www.ijirset.com

Vol. 8, Issue 7, July 2019

types the transceiver needs two pair of electrodes. In capacitive coupling only one of the electrodes (signal electrode) of the transmitter side and receiver side is attached to the body, while the other electrode (ground electrode) is floating.

A. ADXL3XXACCELEROMETER



Fig.4. Adxl3xx Accelerometer

Three axis acceleration sensing device provides analog voltages on three axis X, Y, Z which are proportional to the accelerations [4]. As the device generates analog voltage, it is interfaced to the analog portA of PIC16F877A. X, Y, Z pins of the ADXL320 are connected to the AN2, AN1 and AN0 of PIC16F877A. The micro controller forwards the analog voltages to the A to D converter on three different channels, which converts the analog signal into 10-digit number. The sensor is a polysilicon surface micro machined structure built on top of a silicon wafer. Polysilicon springs suspend the structure over the surface of the wafer and provide a resistance against acceleration forces. Deflection of the structure is measured using a differential capacitor that consists of independent fixed plates and plates attached to the moving mass.

The fixed plates are driven by 180° out-of-phase square waves. Acceleration deflects the moving mass and unbalances the differential capacitor resulting in a sensor output whose amplitude is proportional to acceleration. Phase sensitive demodulation techniques are then used to determine the magnitude and direction of the acceleration.

The demodulator output is amplified and brought off-chip through a 32 k resistor. The user then sets the signal band-width of the device by adding a capacitor. Filtering improves measurement resolution and helps prevent aliasing.

International Journal of Innovative Research in Science, Engineering and Technology

(A High Impact Factor, Monthly, Peer Reviewed Journal)

Visit: www.ijirset.com

Vol. 8, Issue 7, July 2019

V. EXPERIMENTAL RESULTS

Sensitivity is the ratio of change in acceleration (input) to change in the output signal. It is the absolute minimum amount of change in input signal which can be detected by the measuring device. This defines the ideal, straight-line relationship between acceleration and output. For analog-output sensors, sensitivity is ratio metric to supply



VI. CONCLUSION

This paper has successfully proposed an intra body communication (IBC) system. IBC is a new short range non-RF wireless communication technique specified by the IEEE 802.15.6 using the human body as a transmission medium. We reviewed the current IBC coupling methods, various IBC models, and latest transceiver designs. As it stands, the IBC technique potentially offers a more power efficient and naturally secure short-range communication method for body sensor networks, compared to wireless RF. Though ratified in a standard, there are still remaining challenges such as the effect of user motion on transmission quality, increasing data rates for low frequency carriers and effect of long-term use on health which requires further advances before this technology matures.

REFERENCES

- [1] MirHojjat Seyedi*, student Member, IEEE, Behailu Kibret, Student Member, IEEE, Daniel T. H. Lai, Member, IEEE, and Michael Faulkner, Member, IEEE. A Survey on intra body Communications for Body Area Network Applications. IEEE Transactions on Biomedical Engineering vol 60, No. 8, Aug 2013.
- [2] D. T. H. Lai, R Begg and M. Palaniswami, Healthcare sensor networks: Challenges Toward Practical Implementation. Boca Raton, FL, USA: CRC Press, 2011.
- [3] T. Falck, H Baldus, J. Espina, and K Klabunde, "Plug'n play simplicity for wireless medical body sensor", Mobile Netw Appl., vol 12, pp. 143-153, 2007.
- [4] J. Bae, K. Song, H Lee, H Cho, and H-J Yoo, "A low energy crystalline double-FSK sensor node transceiver for wireless body-area network." IEEE J. Solid-State Circuits, vol.47, no. 11, pp. 2678-2692, Nov 2012.
- [5] M. H. Seyedi, B. Kibert, D. Lai, and M. Faulkner, "An empirical comparison of limb joint effects on capacitive and galvanic coupled intra-body communications." Presented at the 8th IEEE Int. Conf Intell. Sens. Netw Inf Process., Melbourne, Australia, Apr. 2013, to be published.
- [6] S. Adibi, "Link technologies and BlackBerry mobile health (mHealth) solutions. A Review." IEEE Trans. Inf Technol. Biomed., vol 16, no. 4 pp. 586-597, Jul 2012.
- [7] M. S. Wegmueller, M. Oberle, N. Felber, N. Kuster and W. Fichtner, "Signal transmission by galvanic coupling through the human body," IEEE Trans. Instrum Meas., vol. 59, no. 4, pp.963-969, Apr. 2010