



e-ISSN: 2319-8753 | p-ISSN: 2320-6710

# IJIRSET

International Journal of Innovative Research in  
**SCIENCE | ENGINEERING | TECHNOLOGY**

# INTERNATIONAL JOURNAL OF INNOVATIVE RESEARCH

IN SCIENCE | ENGINEERING | TECHNOLOGY

Volume 10, Issue 3, March 2021

**ISSN** INTERNATIONAL  
STANDARD  
SERIAL  
NUMBER  
INDIA

**Impact Factor: 7.512**

9940 572 462

6381 907 438

[ijirset@gmail.com](mailto:ijirset@gmail.com)

[www.ijirset.com](http://www.ijirset.com)

# Smart Road Safety Accident Prevention System

Krishnaveni M<sup>1</sup>, Abhinaya K M<sup>2</sup>, Gayathri S<sup>3</sup>, Karthikayini P<sup>4</sup>, Kiruthika D<sup>5</sup>

Assistant Professor, Department of Electronics and Communication Engineering, AVS Engineering College, Salem,  
Tamil Nadu, India<sup>1</sup>

UG Scholars, Department of Electronics and Communication Engineering, AVS Engineering College, Salem,  
Tamil Nadu, India<sup>2345</sup>

**ABSTRACT:** This system presents autonomous accident preventions with security enabling techniques and accident detection system. In recent days vehicle accidents are one of the most leading causes of fatality. Increase in the number of vehicles on road increases the traffic hazards and accident. To prevent the mishap, initially check whether the person consumes alcohol. Accident may also occur because of the person fell asleep so that it ensure whether the person is awake. This system which is developed automatically to detect a mishap and alert the nearest hospitals and medical services about it. And then the Accident information system will get activated, message will be transmitted to respective authority using GSM and including the location using GPS. The system will reduce the number of accidents and also prevent valuable human lives.

**KEYWORDS:** RF transmitter and receiver, Alcohol sensor, Eye blink sensor, GPS and GSM.

## I. INTRODUCTION

Vehicle accident may be terribly huge downside in different countries. Most of the deaths within the world area unit because of road accidents. Reasons for road accidents square measures speed driving, drink and drive, drowsiness. To prevent the accident, uses the alcohol sensor and eye blink sensor to reduce the mishap. The projected system is employed

## II. RELATED WORK

A literature survey is done to know the existing techniques their significance and limitations. It also includes various proposed technique and their advantages.

1. Wireless black box report for tracking of accidental monitoring in vehicles - shaik khadar bashal, p.sireesh babu  
The following paper is to develop a wireless black box using MEMS accelerometer accidental monitoring. MEMS is a Micro electro mechanical sensor which is is a high sensitive sensor and capable of detecting the tilt. This device can perform all the tilt functions like forward, reverse, left and right directions. The system consists of cooperative components of an accelerometer, microcontroller unit, GPS device and GSM module. If any accident occurs, this wireless device will send mobile phone a short message indicating the position of vehicle by tracing the location of the vehicle through GPS system to family member, emergency medical service (EMS) and nearest hospital. The threshold algorithm and speed of motorcycle are used to determine fall or accident in real-time. and GPS tracking system for accidental monitoring

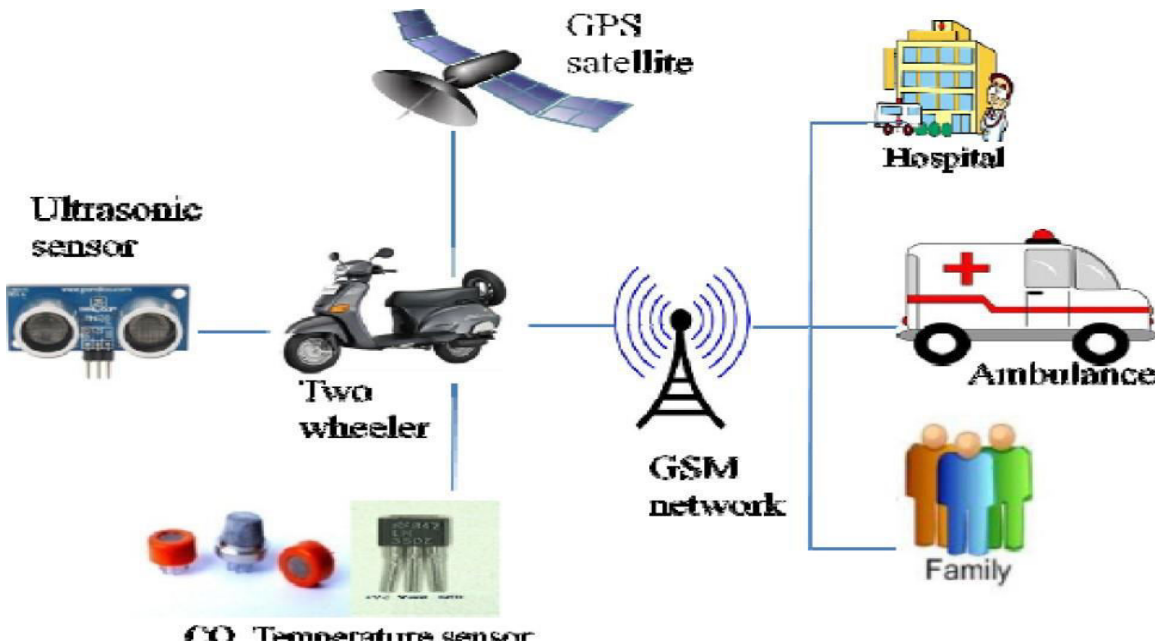

MEMS is a Micro electro mechanical sensor which is a high sensitive sensor and capable of detecting the tilt. This device can perform all the tilt functions like forward, reverse, left and right directions. The system consists of cooperative components of an accelerometer, microcontroller unit, GPS device and GSM module. If any accident occurs, this wireless device will send mobile phone a short message indicating the position of vehicle by tracing the location of the vehicle through GPS system to family member, emergency medical service (EMS) and nearest hospital. The threshold algorithm and speed of motorcycle are used to determine fall or accident in real-time. In this project we are also using temperature sensor and CO sensor which are interfaced to the micro controller. With the help of temperature sensor we can measure amount of temperature exhausted from the vehicle. CO sensor will sense the amount of CO gas emitted from the vehicle. Whenever the CO gas level exceeds the threshold limit then the motor of the vehicle is stopped. Ultrasonic sensor in the module is used to detect any obstacle in the surroundings of the vehicle and intimates the microcontroller and the controller calculates the distance between the vehicles and if the distance is very less.

2. Accident Prevention Using Eye Blinking and Head Movement- Chetna Bharti, Seema V.Arote, Chetna Bharti

This paper describes a real-time online prototype driver-fatigue monitor. It uses remotely located chargecoupled-device cameras equipped with active infrared illuminators to acquire video images of the driver. Various visual cues that typically characterize the level of alertness of a person are extracted in real time and systematically combined to infer the fatigue level of the driver. The visual cues employed characterize eyelid movement, gaze movement, head movement, and facial expression. A probabilistic model is developed to model human fatigue and to predict fatigue based on the visual cues obtained. The simultaneous use of multiple visual cues and their systematic combination yields a much more robust and accurate fatigue characterization than using a single visual cue. This system was validated under real-life fatigue conditions with human subjects of different ethnic backgrounds, genders, and ages; with/without glasses; and under different illumination conditions. It was found to be reasonably robust, reliable, and accurate in fatigue characterization.

Sleep related accidents tend to be more severe, possibly because of the higher speeds involved and because the driver is unable to take any avoiding action, or even brake, prior to the collision. Home describes typical sleep related accidents as ones where the driver runs off the road or collides with another vehicle or an object, without any sign of hard braking before the impact. In 2002, the National Highway Traffic Safety Administration (NHTSA) estimated that 35 percent of all traffic deaths occurred in crashes in which at least one driver or no occupant had a BAC(Blood Alcohol Content) of 0.08 percent or more and that any alcohol was present in 41 percent of all fatal crashes in 2002. Such statistics are sometimes cited as proof that a third to half of all fatal crashes are caused by "drunk driving" and that none of the crashes that involve alcohol would occur if the alcohol were not present. But this is incorrect and misleading because alcohol is only one of several factors that contribute to crashes involving drinking drivers. Furthermore, some fatally injured people in alcohol-related crashes are pedestrians with positive BACs, and these fatalities still would



occur even if every driver were sober. Distracted driving is a top danger behind the wheel. In fact, about eight out of 10 crashes involve some sort of driver inattention within three seconds of that crash. We've all seen it and likely even done it, driving distracted includes anything from talking on the phone, to messing with your music, to attending to your children or even pets. All of these actions can lead to serious consequences. Martha Meade with AAA Mid-Atlantic says, "People are dying because of a simple missed phone call, a dropped toy or some other event that is completely not important." Possible techniques for detecting drowsiness in drivers can be generally divided into the following categories: sensing of physiological characteristics, sensing of driver operation, sensing of vehicle response, monitoring the response of driver.

### III. PROPOSED SYSTEM

Whenever a person sits in driver seat of a vehicle, the system checks for following parameters with the driver. The alcohol sensor checks if the person has consumed alcohol or not. MQ3 sensor is suitable for detecting alcohol concentration from driver's breath. It has high sensitivity and fast response time. It provides an analog output based on alcohol concentration. If a drunk driver tries to sit on a driver seat, then the alcohol sensor MQ3 detects the presence of alcohol sensor, blow the buzzer and stop the fuel, unless the alcoholic person is replaced by a normal person the vehicle wouldn't ignite. The eye sensor ensures that the person in driver seat does not fall asleep, when the person fall asleep, it blows the buzzer and stop the fuels as like as previous case. If an accident has occurred, the piezoelectric sensor provides a high value and it indicates the occurrence of an accident. Once Arduino detects the accident or set bit through measuring instrument detector, Arduino activates the GSM module that has a manually saved signal of friend of accident victim, send a prestored SMS to that selection. Simultaneously, it further offers the message to the many friends that accident had occurred. This technique is known as automatic emergency message system. The GSM equipment sends associate in nursing SMS to the predefined mobile variety and informs regarding the accident and it includes the location of the accident occurred using GPS. Using this system, the time gap between the accident occurrence and medical personnel are reduced to save the human lives.

### IV. BLOCK DIAGRAM

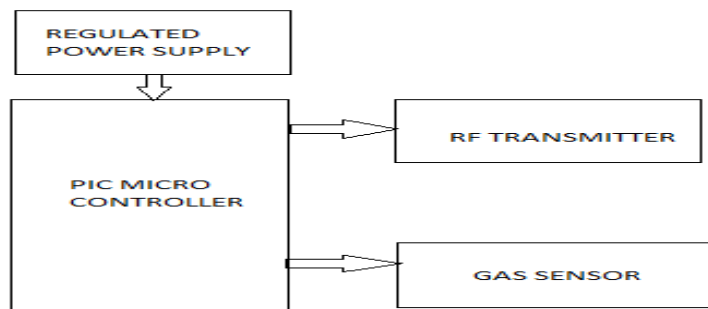

Block diagram for transmitter side

#### A. PIC CONTROLLER

The original PIC was built to be used with General Instrument's new CP1600 16-bit CPU. While generally a good CPU, the CP1600 had poor I/O performance, and the 8-bit PIC was developed in 1975 to improve performance of the overall system by offloading I/O tasks from the CPU. The PIC used simple microcode stored in ROM to perform its tasks, and although the term was not used at the time.

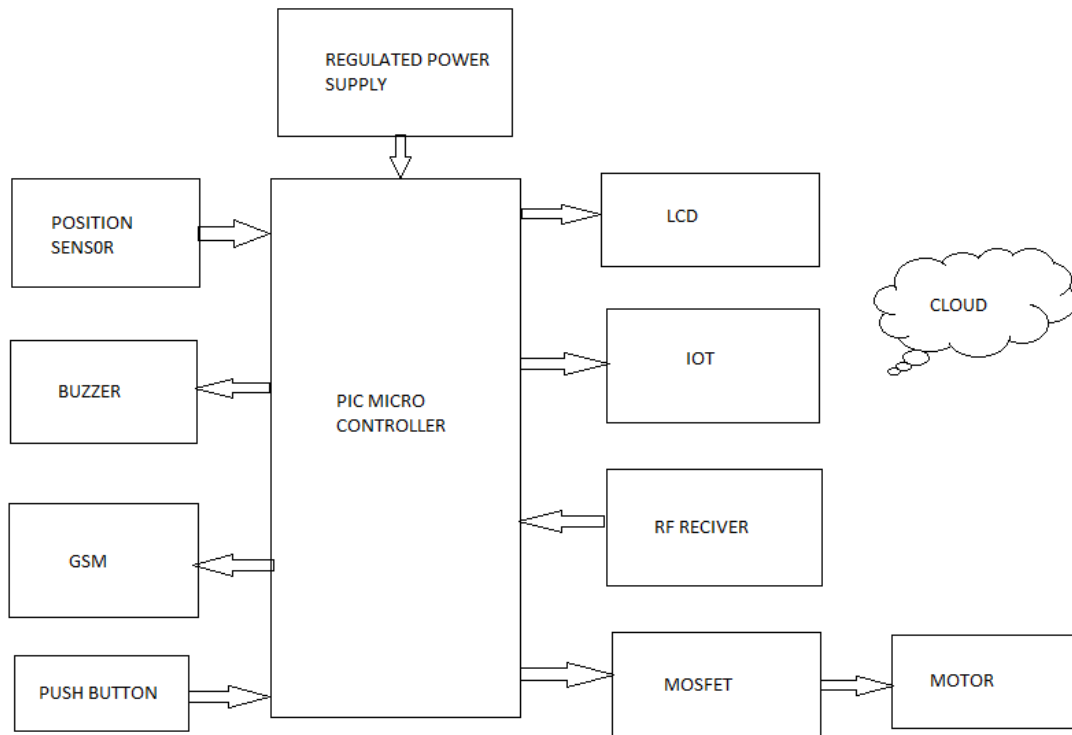

Block diagram for receiver side

**B. RF TX RX**



The TX is an ASK transmitter module. The TX is designed specifically for remote-control, wireless mouse and car alarm system operating at 315/433.92 MHz. The RX is a miniature receiver module that receives On-off keyed (OOK) modulation signal and demodulated to digital signal for the next decoder stage. The RX is designed specifically for remote-control and wireless security receiver operating at 315/434Mhz. UART TTL o/p - Baud Rate – 9600

**C . GSM/GPRS Module**

GSM/GPRS module is used to establish communication between a computer and a GSM-GPRS system. Global System for Mobile communication (GSM) is an architecture used for mobile communication in most of the countries. Global Packet Radio Service (GPRS) is an extension of GSM that enables higher data transmission rate. GSM/GPRS module consists of a GSM/GPRS modem assembled together with power supply circuit and communication interfaces (like RS-232, USB, etc) for computer.



A GSM/GPRS MODEM can perform the following operations:

- Receive, send or delete SMS messages in a SIM.
- Read, add, search phonebook entries of the SIM. Make, Receive, or reject a voice call.

#### D. GPS

The Global Positioning System (GPS) is a spacebased satellite navigation system that provides location and time information in all weather conditions, anywhere on or near the earth where there is an unobstructed line of sight to four or more GPS satellites. The system provides capabilities to military, civil and commercial users around the world. It is maintained by the United States government and is freely accessible to anyone with a GPS receiver.

#### E. ALCOHOL SENSOR

The MQ series of gas sensors utilizes a small heater inside with an electro chemical sensor these sensors are sensitive to a range of gasses are used at room temperature. MQ135 alcohol sensor is a  $\text{SnO}_2$  with a lower conductivity of clean air. When the target explosive gas exists, then the sensor's conductivity increases more increasing more along with the gas concentration rising levels. By using simple electronic circuits, it convert the change of conductivity to correspond output signal of gas concentration

The MQ135 gas sensor has high sensitivity in ammonia, sulfide, benzene steam, smoke and in other harmful gas. It is low cost and suitable for different applications. There are different types of alcohol sensors like MQ-2, MQ-3, MQ-4, MQ-5, MQ-6, etc.

#### V. CONCLUSION

An efficient smart vehicle system has been proposed which gives good security to driving. We have done a detailed survey among the existing systems for vehicles. On the basis our analysis we are proposing smart vehicle method. The advantages of the proposed system over other methods include prevention of accidental injuries, to Improve safety of driving to Discourages careless driving, Helps to control traffic violation by an Adaptable simple Method which is of Low cost.

#### REFERENCES

1. Emerging Trends in Computer Science and Information Technology 2012 (ETCSIT2012) Proceedings published in International Journal of Computer Applications @ (IJCA)
2. IOSR Journal of Computer Science (IOSR-JCE) ISSN: 2278-0661, pISSN: 2278-8727 PP 39-42 [www.iosrjournals.org](http://www.iosrjournals.org)
3. INTERNATIONAL JOURNAL OF PROFESSIONAL ENGINEERING STUDIES 4.978-0-7695-5146-3/13 \$26.00 © 2013 IEEE  
DOI 10.1109/T11EC.2013.1
4. Government of India, Ministry of Road Transport and Highways, Lok Sabha Unstarred Question No.374 Answered.
5. R. Ramani, S. Valarmathy, Dr. N. Suthanthira, S. selvaraju, M. thirupathi, R. thagam, Vehicle Tracking and locking Based GSM and GPS, Issue Date: Sept 2013
6. GONG xiaoyan, TAN Gshuming, WANG feiyue, Traffic incident detection algorithm based on non-parameter regression IEEE 2002.
7. Cellular networks for massive IOT ERICSON White paper, jan 2016.
8. LYLA Bb Das, Embedded systems – an integrated approach, first impression, pearson, 2013
9. Vijay savani, HARDIK Agarwal, dhruvil patel, alcohol detection and accident prevention of vehicle, international journal of innovative and emerging research in engineering research in engineering, volume 2, issue 3 2015



**INNO**  **SPACE**  
SJIF Scientific Journal Impact Factor

**Impact Factor:  
7.512**

**ISSN** INTERNATIONAL  
STANDARD  
SERIAL  
NUMBER  
**INDIA**



# INTERNATIONAL JOURNAL OF INNOVATIVE RESEARCH

IN SCIENCE | ENGINEERING | TECHNOLOGY

 **9940 572 462**  **6381 907 438**  **ijirset@gmail.com**



[www.ijirset.com](http://www.ijirset.com)

Scan to save the contact details