

Measurement of Complex Permittivity of Dielectrics and Its Applications

Pravin K. Bhadane^{#1}, Sheetal V. Bambal^{#2}^{#1,2}Department of Electronics, Nowrosjee Wadia College Pune-411 001, India

ABSTRACT: Measurement of dielectric properties provide valuable information about the physical parameters of agricultural & food products. Precise measurement of complex permittivity (CP) gives details of moisture content in products. In the present work we have used simple electronic method for the measurement of CP. We have used microcontroller for measurement & calibration of CP. The electronic circuit is designed with the help of low cost locally available components. The software program is developed in C language in Keil environment. The results obtained for CP are accurate and can be used for the estimation of moisture content. The electronic circuit can be used for the measurement of other dielectric properties such as dielectric strength & loss. The combine effect of all the dielectric properties can be easily implemented in the software.

KEYWORDS: permittivity, microcontroller, dielectric.

I. INTRODUCTION

Permittivity is the property of a dielectric material and depends on its molecular structure. The permittivity also depends on environment related parameters such as temperature and moisture content [1]. The food and agricultural products can conduct electric current to some degree, but they also show dielectric properties [2]. For the dielectric properties the main parameter is the complex permittivity which describes the material behaviour when it is subjected to an electric field.

The dielectric measuring techniques can be divided into two main categories namely, resonant and non-resonant, the resonant methods can characterize the material at single frequency. In this method a dielectric material used as a resonant element. A non-resonant method can measure over the broad range of frequencies. It can categorize the material by determining the reflection and transmission coefficients that causes changes in characteristics impedance and wave velocity [3].

Interest in electric properties of agricultural materials has increased as the agricultural technology has become more sophisticated, as new devices for characterization are being developed. Electric properties of agricultural products have been of interest for many years. One of the earliest applications of such electrical properties was the study of dc electrical resistance of grain for rapid determination of its moisture content. Waterer found a logarithmic increase in electrical resistance as the moisture content of grain decreased [4]. He had used direct current conductivity method for measuring the moisture content of grains. Since bulk grain is a mixture of grain particles and air, measurement of the dielectric properties is more difficult than if it were a homogeneous substance consisting of grains only [5]. There is a need of better automated measurement technique for the measurement of permittivity. The objective of this work was to investigate simple automatic device for measurement of permittivity of agricultural material.

II. EXPERIMENTAL WORK

The dielectric properties, or permittivity, of a material determine the interaction of that material with electric field. For practical use, the dielectric properties of usual interest are the dielectric constant and the dielectric loss factor, the real and imaginary parts, respectively, of the relative complex permittivity,

$$\epsilon = \epsilon' - j\epsilon'' = |\epsilon|e^{-j\delta}$$

where δ is the loss angle of the dielectric. In this article, "permittivity" is understood to represent the relative complex permittivity, i.e., the permittivity relative to free space. The capacitive technique is the simplest practical method for

International Journal of Innovative Research in Science, Engineering and Technology

(An ISO 3297: 2007 Certified Organization)

Vol. 3, Issue 6, June 2014

the measurement of the permittivity. The parallel plate capacitor method involves sandwiching of a dielectric material (agricultural sample) between two plates to form a capacitor. In the present work, a parallel plate capacitor (cell) with plate area $100 \times 10^{-4} \text{ m}^2$ and separation distance 10^{-2} m has been constructed for the measurement of permittivity. Since capacitor is a physical device, it has constant plate surface area (A) and distance between the plates (d). Changes in its capacitance are then dependent only on dielectric properties of the material placed between the plates. Converting a capacitor into a permittivity sensor is practically quite simple, the material to be tested is placed between the capacitor plates as the dielectric, as shown in Figure 1.

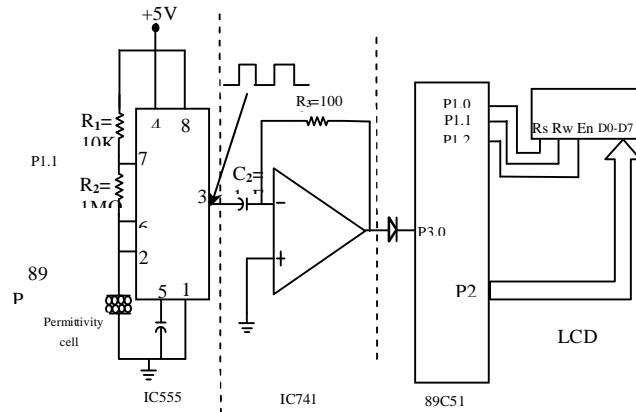

Figure 1 : Circuit diagram for the measurement of permittivity.

III. RESULTS AND DISCUSSION

The oscillator circuit uses the permittivity cell as a timing capacitor. It generates square wave oscillations of frequency 8 MHz for the empty cell. When the cell is filled with agricultural sample then increase in the frequency observed. The square wave signal is converted into differentiated signal i.e. spikes. Diode is used as clipper for negative spikes. Time period between two positive spikes and the corresponding frequency has been measured by microcontroller program. The program also calculates the permittivity by following formula.

$$E = (1.44 \times d) / (R1 + 2 \times R2) \times A \times f$$

Figure 2 shows the flowchart of the permittivity computation program. The steps involved in the measurement of frequency and its conversion into permittivity are shown in the flowchart. The device has been used to measure the permittivity of some food grains. The measured permittivities are depicted the Table I.

Grain	Permittivity (X 10^{-12} Fm^{-1})
sunflower	17.70
lime	17.70
cotton	26.55
corn	26.55
olive	27.43
coconut	28.32
wheat	35.40

TABLE I : PERMITTIVITY OF SOME FOOD GRAINS.

The software program has been developed in the C language and listed at the end of the article. The source code is compiled in Keil IDE and programmed into microcontroller ATMEL 89C51 with the help of μC -flash programmer. Soft copy of source code can be obtained freely from the authors.

International Journal of Innovative Research in Science, Engineering and Technology

(An ISO 3297: 2007 Certified Organization)

Vol. 3, Issue 6, June 2014

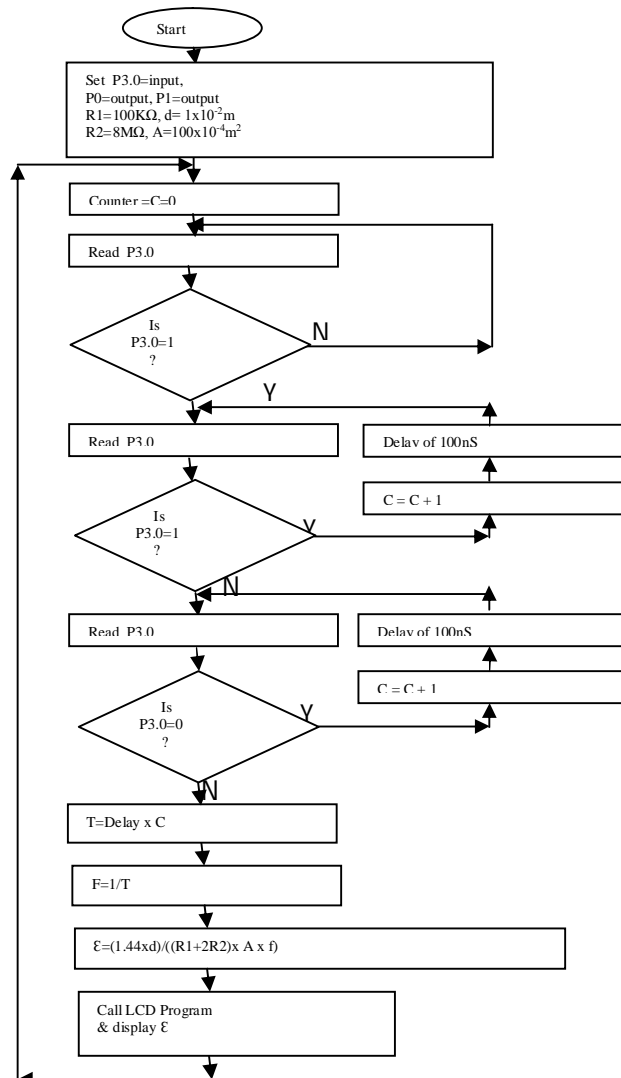

Figure 2 : Flowchart for the permittivity measurement.

IV. CONCLUSIONS

The device for the measurement of permittivity has been developed. It includes construction of electronic circuit and the software program. The required electronic components are low cost and locally available. The device has been successfully tested for some agricultural samples. The program has been tested for some fruits and the obtained results are dependable. The charging – discharging cycle of capacitor minimizes the dielectric loss and polarization effect. The moisture content is proportional to the permittivity of sample and the relationship between them can be established from the observations. Our future plan is to interface circuit with Computer for the continuous measurement of permittivity and its graphical analysis.

International Journal of Innovative Research in Science, Engineering and Technology

(An ISO 3297: 2007 Certified Organization)

Vol. 3, Issue 6, June 2014

ACKNOWLEDGEMENT

The authors are sincerely thankful to the Principal, N. Wadia College, Pune for his kind support.

REFERENCES

- [1] S.O. Nelson, L.H. Soderholm, and F.D. Yung, "Determining the dielectric properties of grain," *Agricultural Engineering*, vol. 34(9), pp.608-610, 1953.
- [2] C. Gabriel, S. Gabriel, and E. Corthout, "The Dielectric Properties of Biological Tissues : I. Literature survey," *Physics in Medicine and Biology*, vol. 41, pp. 2231-2249, 1996.
- [3] M.S. Venkatesh and G.S. V. Raghavan "An Overview of Dielectric Properties Measuring Techniques," *Canadian biosystems engineering*, vol. 47, pp. 7.15-7.30, 2005.
- [4] D. Waterer, W.E. Muir, and R. N. Sinha, "Electrical resistance probe for detecting stored grain deterioration," *Canadian Agricultural Engineering*, vol. 27, pp. 73-77, 1985 .
- [5] S. O. Nelson, P.G. Bartley, "Measuring Frequency and Temperature Dependent Permittivities of Food Materials," in *IEEE transactions on instrumentation and measurement*, vol. 51 (4), pp.589-592, 2002.

```
// program to calculate the permittivity and display it on
// the LCD
/***** Header Files Declaration *****/
#include<reg51.h>
#include<stdio.h>
/***** LCD control signals declaration *****/
sbit rs = P1^0; // Register Select line
sbit rw = P1^1; // Read/write line
sbit en = P1^2; // Enable line
sbit sq = P3^0;
#define lcdport P2 // LCD data lines are connected to P2
/***** LCD function prototypes *****/
void lcdcmd(unsigned char);
void lcddata(unsigned char);
void lcdinit(void);
void delay(unsigned int);
/**** Main Function declaration *****/
void main()
{
    char arr1[]="PERMITIVITY";
    double e;
    int i;
    int c;
    int d=1,a=100,e1;
    double t,f;
    double r1=100000,r2=10000000;
    lcdport = 0x00; // Make the port as output port
    lcdinit(); // LCD initialization
    while(1)
    {
        c=0;
        while(sq==0);
        while(sq==1)
        {
            c=c+1;
            for(j=0;j<=0;j++);
        }
    }
}
```

International Journal of Innovative Research in Science, Engineering and Technology

(An ISO 3297: 2007 Certified Organization)

Vol. 3, Issue 6, June 2014

```
}
while(sq==0)
{
c=c+1;
for(j=0;j<=0;j++);
}
t=100*c;
f=1000000000/t;
e = ((1.44*d) * 1000000000000)/((r1+2*r2)*a*f);
e1=(int)e;
lcdcmd(0x85);
delay(100);
for(i=0;arr1[i]!='\0';i++)
{
lcddata(arr1[i]);
}
delay(500); // Delay of 0.5sec
lcdcmd(0xC6); // Force cursor to the 2nd line
delay(100);
lcddata(char(e1));
delay(500);
}
}
/*****LCD Initialization Function declaration */
void lcdinit()
{
lcdcmd(0x38); // configuring LCD as 2 line
lcdcmd(0x0E); // Display on, Cursor blinking
lcdcmd(0x01 // Clear Display Screen
}
/* LCD Command Sending Function declaration */
void lcdcmd(unsigned char command)
{
lcdport = command;
rs = 0; // Select Command Register
rw = 0; // write operation
en = 1; // High to Low pulse
delay(1); // 1 ms delay
en = 0;
}
/** LCD data Sending Function declaration */
void lcddata(unsigned char value)
{
lcdport = value;
rs = 1; // Select Data Register
rw = 0; // write operation
en = 1; // High to Low pulse with nearly 1ms
delay(1); // 1 millisecc delay
en = 0;
delay(100); // 100 millisecc delay
}
/****delay Function declaration ****/
```

International Journal of Innovative Research in Science, Engineering and Technology

(An ISO 3297: 2007 Certified Organization)

Vol. 3, Issue 6, June 2014

```
void delay(unsigned int val)
{
  unsigned int i,j;
  for(i=0;i<=val;i++)
  {
    for(j=0;j<=0;j++);
  }
}
```