

International Journal of Innovative Research in Science, Engineering and Technology

(An ISO 3297: 2007 Certified Organization)

Vol. 4, Issue 8, August 2015

Performance Analysis of Production Line A Case Study in Small Scale Industry

Santosh Kulkarni ¹, G.R.Naik ²

P.G. Student, Department of Production Engineering, K.I.T's Engineering College, Kolhapur, Maharashtra, India¹

Associate Professor, Department of Production Engineering, K.I.T's Engineering College, Kolhapur, Maharashtra,
India²

ABSTRACT Performance analysis is the ongoing monitoring and reporting of functions accomplishments, particularly progress towards pre established goals. It is typically conducted by management. Performance measures may address the type or level of program activities conducted (process), the direct products and services delivered by a program (outputs), and/or the results of those products and services (outcomes). This paper describes a case study which is under observation, by preliminary analysis several issues are came out which is hampering the performance of production line so to analysing the production line and find out issues to enhance the production line which is a need. To measure the performance of production line OEE method is used.

KEYWORDS: Performance Analysis, OEE, WIP Inventory, DMAIC, Queuing theory, Raw Material Inventory.

I. INTRODUCTION

Performance analysis is measuring the output of a particular business process then modifying the process or procedure to increase the output, increase efficiency, or increase the effectiveness of the process or procedure. Performance improvement can be applied to either individual performance such as organizational performance such as a commercial business.[3]. Performance analysis involves determining what to measure, identifying data collection methods, and collecting the data. Evaluation involves assessing progress toward achieving performance expectations, usually to explain the causal relationships that exist between program activities and outcomes. Performance measurement and evaluation are components of performance- based management, the systematic application of information generated by performance plans, measurement, and evaluation to strategic planning and budget formulation [18].

There are several benefits of performance analysis like strengthens accountability[7], enhances decision-making, improves customer service, assists management in determining effective resource use, supports strategic planning and goal-setting, provides early detection of problems, and it can potentially enhance the rating etc.

In order to succeed with the goal of long term survival and the ability to produce useful output manufacturing companies continuously make decisions regarding e.g. the deployment of resources. Irrespective of whether the decisions are conscious or, not, they determine how the company is operated. By actively taking charge over the decisions the competitive position of a company can be shaped over time. [11]

Performance analysis and Productivity growth are interlinked with each other because performance growth is important to the firm, it means that it can meet its (perhaps growing) obligations to workers, shareholders and governments and still remain even improve its competitiveness in the market place. The way to promote growth in output is bring additional inputs into production adding more inputs will not increase the income earned per unit of input. In fact, it is likely to mean lower average wages and lower rates of profit. But, when there is productivity growth, even the existing commitment of resources generates more output and income. Income generated per unit of input increases. Additional resources are also attracted into production and can be profitably employed [5].

International Journal of Innovative Research in Science, Engineering and Technology

(An ISO 3297: 2007 Certified Organization)

Vol. 4, Issue 8, August 2015

II. LITERATURE REVIEW

Michael Manitz: described an approximation procedure for determining the throughput of such an assembly line. Exact solutions are not available in this case. For performance evaluation, a decomposition approach is used. The two-station subsystems are analyzed by G/G/1/N stopped-arrival queuing models. In this heuristic approach, the virtual arrival and service rates, and the squared coefficients of variation of these subsystems are determined. A system of decomposition equations which are solved iteratively is presented. Any solution to this system of equations indicates estimated values for the subsystems' unknown parameters.

Na Li, Shiqing Yao, George Liu, Caihua Zhuang: studied the optimization problem in setting the suitable total Work in- Process (WIP) level and the distribution in the three loops from the view of the trade-off between the throughput and the WIP level for the system is addressed. In the proposed model, the system is firstly modelled as a three-loop closed queue network and they propose an approximate method to evaluate the performance. Secondly, a Genetic Algorithm is designed to obtain near optimal results based on the performance evaluation.

Viswanadham and Narahari: offer a unique effort in presenting a unified and systematic treatment of various modeling methodologies and analysis techniques for performance evaluation of automated manufacturing systems. They begin with an overview of automated manufacturing systems, and then move on to provide a comprehensive discussion of three principal analytical modelling paradigms: Markov chains, queues and queuing networks and Petri nets. They also deal with the transient analysis of manufacturing systems performance and the important topic of performability of automated manufacturing systems.

Buzacott and Shanthikumar : who provide a comprehensive treatment of stochastic models of manufacturing systems, and develop stochastic models that evaluate the performance, address issues in the design, control and operation of these systems, and provide an understanding of how different components of a manufacturing system can be coordinated. The authors present new treatments of such classical issues as workload allocation and new models of assembly systems with strict job sequence requirements. In addition, they have developed a new framework to describe the interaction between information and material flow in manufacturing.

Askin and Standridge: provide an introduction to the analysis of manufacturing systems using analytical and experimental models. They bring together useful models and modelling approaches that address a wide variety of manufacturing system design and operation issues.

Papadopoulos, Heavey and Browne: describe the modelling of manufacturing systems using queuing network models and two other closely related modelling techniques, simulation modelling and generative models for the buffer allocation problem. The main purpose of this work is to provide an overview of past research in this area.

Zhai: investigated the job shop bottleneck detection based on orthogonal experiment. Here, detection of bottleneck machine before manufacturing system run and guide the production process for the improvement of performance of manufacturing systems. On order to to evaluate the performance of the proposed method, different scales of job shop scheduling instances and two existing bottleneck detection methods are selected for simulation. The result shows that prior-to-run bottleneck detection method is feasible, efficient and easily implemented.

III. CASE STUDY UNDER OBSERVATION

A case study which is under observation, four months data (January 2015-April 2015) is taken for preliminary analysis. In a company the production of hub is carried out according to monthly demand from customers. Once the customers place order, the production planning and control department schedule for monthly production. Company divide monthly production requirement into weekly production requirement and weekly into daily production requirement.

International Journal of Innovative Research in Science, Engineering and Technology

(An ISO 3297: 2007 Certified Organization)

Vol. 4, Issue 8, August 2015

Layout of Hub Production Line

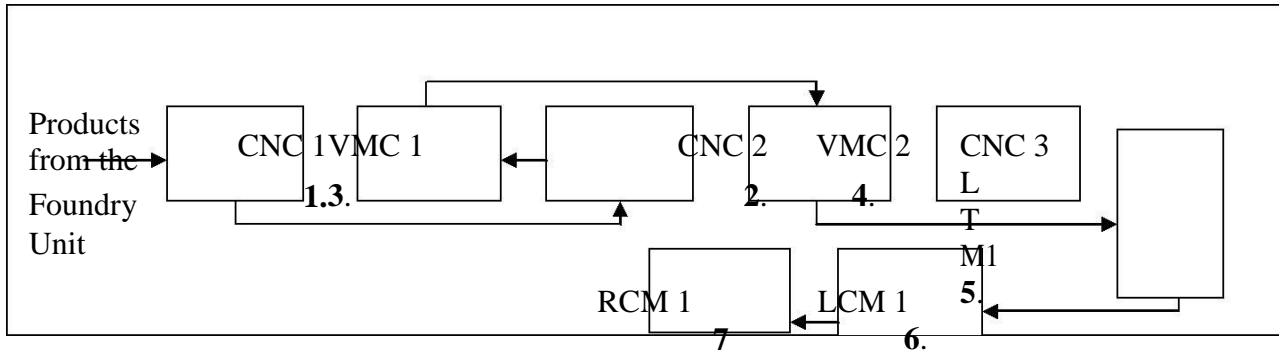

Fig no. 01- Layout of Hub Production Line

When casting of hub product is completed from foundry unit the products come to the raw material store point, where the inspections of casting products are carried out. If the products comes with some defects like blow holes, cold shuts, extra material etc. then products are send it to foundry department with proper reason. After these inspections of products, they are sent it to machine shop, with Ok tag. The hub product is machined on four different machining centres (CNC and VMC), one leakage testing centre (LTM), one laser coding centre (LCM) and rotary cleaning machine (RCM). The hub production line consists of CNC1, CNC2, VMV1, VMC2, LTM1, LCM1, and RCM1.

Phase I

By using past data since January 2015 and observation the data collected as below:-

Part Name – (Hub 353)		Part No: 1731-18								
Month	Hub Schedule	Week 1 st		Week 2 nd		Week 3 rd		Week 4 th		Total Prod.
		Plan	Actual Qty.	Plan	Actual Qty.	Plan	Actual Qty.	Plan	Actual Qty.	
Jan 2015	3000	750	468	750	510	750	490	750	482	1950
Feb 2015	3000	750	478	750	489	750	469	750	483	1919
March 2015	3000	750	494	750	480	750	478	750	485	1937
April 2015	3000	750	473	750	459	750	463	750	474	1869

Fig No 02- Dispatch Record

International Journal of Innovative Research in Science, Engineering and Technology

(An ISO 3297: 2007 Certified Organization)

Vol. 4, Issue 8, August 2015

Performance Parameters:

Month	O.T.D (On Time Delivery in %)	Work In Process Units
Jan-15	64.20	1050
Feb-15	63.96	1081
March-15	64.58	1063
April-15	62.30	1131

Fig no. 03 Performance Parameters

The company's average manufacturing is only 1900 units of hub per month but requirement is 3000 units per month which means the on time delivery of the hub is only 63%, due to this the numbers of WIP units are increasing and the revenue is decreasing. So from these parameters company facing major problem related to

- Problem associated with dispatch.
- Problem associated with work-in-process inventory.

Analysis of Revenue

Month	No. Of Units Produced	Profit/Month	Loss of Revenue/Month
Jan-15	1950	Rs. 30030	Rs. 16170
Feb-15	1919	Rs. 29553	Rs. 16647
March-15	1937	Rs. 29783	Rs. 16370
April-15	1869	Rs. 28783	Rs. 17417

Fig No 04 Analysis of Revenue

After preliminary analysis the recorded analysis of revenue from Jan-15 to April-15, so from these parameters the expected profit from this production line is Rs. 46200 and the average loss of revenue is Rs16651/Month.

Time Study of Production Line

The time study is a direct and continuous observation of a task, using a time keeping device (e.g- decimal minute stopwatch, compute assisted electronic stopwatch and video tape camera) to record the time taken to accomplish a task and its often used when:

- There are repetitive work cycles of short to long duration,
- Wide variety of dissimilar work is perform, or
- Process control elements constitute a part of cycle.

In this case study to observe Production Line for time study HD recoding camera is used.

The result of time study is as follows:

Machine	Operation Time (In Min)	Loading and Unloading Time (In Min)	Total Cycle Time (In Min)
CNC1	04.00	0.30	4.30
CNC2	02.30	0.30	3
VMC1	01.30	0.30	2
VMC2	04.00	0.30	4.30
LT1	01.00	1	2
LCM1	01.00	1	2

Fig No 05 Time Study

International Journal of Innovative Research in Science, Engineering and Technology

(An ISO 3297: 2007 Certified Organization)

Vol. 4, Issue 8, August 2015

Phase II

Current status of machines in production line:

To find out efficiency of each machine Overall Equipment Effectiveness (OEE) method is used.

Overall Equipment Effectiveness (OEE)

Overall Equipment Effectiveness (OEE) is a way to monitor and improve the efficiency of your manufacturing process. OEE has become an accepted management tool to measure and evaluate plant floor productivity. OEE is broken down into three measuring metrics of Availability, Performance, and Quality. These metrics help gauge your plant's efficiency and effectiveness and categorize these key productivity losses that occur within the manufacturing process.

OEE empowers manufacturing companies to improve their processes and in turn ensure quality, consistency, and productivity measured at the bottom line. By definition, OEE is the calculation of Availability, Performance, and Quality.

$$\text{OEE} = \text{Availability} \times \text{Performance} \times \text{Quality}$$

Metric 1: Availability

$$\text{Availability} = \text{Run Time} / \text{Total Time}$$

By Definition: Percentage of the actual amount of production time the machine is running to the production time the machine is available. Simple OEE: The total run time of the machine subtracting all unplanned downtime.

Metric 2: Performance

$$\text{Performance} = \text{Total Count} / \text{Target Counter}$$

By Definition: Percentage of total parts produced on the machine to the production rate of machine. Simple OEE: How well a machine is running when it is running?

Metric 3: Quality

$$\text{Quality} = \text{Good Count} / \text{Total Count}$$

By Definition: Percentage of good parts out of the total parts produced on the machine.

Simple OEE: How many good parts versus bad parts a machine has produced.

The OEE of each machine is as follows:

Machine	Availability (%)	Performance (%)	Quality (%)	OEE (%)
CNC1	85	98	90	75
CNC2	83	67	91	51
VMC1	72	51	92	34
VMC2	85	91	92	71
LT1	62	55	98	33
LCM1	66	52	98	34
Avg in %	75.5	69	93.5	50

Fig No. 06 OEE of each Machine

The Overall Equipment Effectiveness (OEE) of the production line is just 50%, so continuous monitoring of the production line is necessary for increment, therefore performance improvement is necessary. It is observed that availability and performance efficiency of the line are the major issue for obtaining excellent level of performance so it is recommended to monitoring machine resources for its optimum utilization and also increase the operating efficiency of the production line. It was also observed that constraint resource can be effectively utilised for production of other component which industry is producing after fulfilling line requirement.

International Journal of Innovative Research in Science, Engineering and Technology

(An ISO 3297: 2007 Certified Organization)

Vol. 4, Issue 8, August 2015

The Financial loss per machine/day is as follows:

Machine	Actual Production (In Units)	Machine Capacity (In Units)	Cost wise Financial Loss (In Rs.)
CNC1	94	96	37
CNC2	89	160	919
VMC1	89	192	1545
VMC2	83	88	158
LT1	83	240	418
LCM1	83	240	393

Fig No.07 Financial loss per Machine/day

By referring the above table cost wise financial loss of CNC2, VMC1, LT1 and LCM1 is more compare to other machines, here first priority is to minimise the financial loss of VMC1 and CNC2. By minimisation of cost which will help the organization to enhance the profit.

Comparison between available capacity and demand placed on each machine

Machine	Available capacity (In Min)	Demand/day (Required capacity)(In Min)	Remark
CNC1	410	538	Constraint Resources
CNC2	400	375	Non Constraint Resources
VMC1	347	250	Non Constraint Resources
VMC2	410	538	Constraint Resources
LT1	300	250	Non Constraint Resources
LCM1	320	250	Non Constraint Resources

Fig No.08 Comparison between available capacity and demand placed on each machine

Waste analysis:-

By inspection and past data, there are many non value added activities are observed which can be minimize by using DMAIC approach which is under process. Following are some non value added activities which are observed in production line:

- ✓ Motion
- ✓ Waiting
- ✓ Over-processing

IV. CONCLUSION

Managing the customer demand is major challenges in today's manufacturing scenario companies are enhancing their productivity by analysing the performance. The OEE method is most suitable for analysis of performance. This paper, discuss the performance analysis of production line for improvement and satisfy the customer demand. The authors are presently focusing on production line of a small scale industry for performance improvement. From current performance analysis which indicates bottlenecks and non added activities in the production line due to this the company not able to fulfil the customer demand. This provides generous scope in performance improvement.

REFERENCES

- [1] Askin, and Standridge, "Selection machines and buffers in unreliable assembly/disassembly manufacturing networks", Int. J. Production Economics154, pp.113-126, 2014
- [2] Riyadh Mohammed Ali Hamza., "Selection of Balancing Method for Manual Assembly Line of Two Stages Gearbox", Global Perspectives on Engineering Management, Vol. 2 Iss. 2, PP. 70-81, 2013

International Journal of Innovative Research in Science, Engineering and Technology

(An ISO 3297: 2007 Certified Organization)

Vol. 4, Issue 8, August 2015

- [3] Papadopoulos, Heavey and Browne., “An Efficient Assembly line Balancing in Automobile Manufacturing”, IEEE , vol.11, 2011
- [4] Na Li, Shiqing Yao, George Liu, Caihua Zhuang. “Optimization of a multi-Constant Work-in-Process semiconductor assembly and test factory based on performance evaluation”, Computers & Industrial Engineering 59, pp. 314–322, 2010
- [5] Michael Manitz., “Queueing-model based analysis of assembly lines with finite buffers and general service times”, Computers & Operations Research 35, pp. 2520 – 2536, 2008
- [6] Chung-Jen Kuo., “Standard WIP Determination and WIP Balance Control with Time Constraints in Semiconductor Wafer Fabrication”, Journal of Quality Vol. 15, No. 6 ,2008
- [7] Viswanadham and Narahari., “Evaluating focused factory benefits with queuing theory”, European Journal of Operational Research 128 , pp. 597-610, 2011
- [8] H.T. Papadopoulos, C. Heavey., “Queuing theory in manufacturing systems analysis and design: A classification of models for production and transfer lines”, European Journal of Operational Research 92, pp. 1-27, 1996
- [9] kua, and van der Wal., “Monotonicity of the throughput in single server production and assembly networks with respect to the buffer sizes”, in:
- [10] H. Perros T. Altiok (eds)., Queuing Networks with Blocking, North-Holland, Amsterdam, pp. 345-356, 2011
- [11] Yao.D., “Majorization and arrangement orderings in open queueing networks”, Annals of Operations Research 9, pp.53 i-543, 2001
- [12] Papadopoulos, H.T., Heavey, and Browne., “Queueing Theory in Manufacturing Systems Analysis and Design”, Chapman and Hall, London, 2012
- [13] Nakata, and Kostelski, “Matrixgeometric and recursive algorithm solution of a two-stage unreliable flow line”, HE Transactions 19/4, pp. 429-438, 1999
- [14] Azmat Nafees., “Queueing theory and its application: Analysis of the sales checkout operation in ICA supermarket”, University of Dalarna, Department of Economics and Society, vol 06, 2007
- [15] L.S. Murty, “Constraint Management- An Indian Case of Throughput Improvement Productivity”, (2001), vol.42, No.2, pp.337-343.
- [16] G.V.Frazier, P. M. Reyes, “Applying Synchronous Manufacturing concept to improve the production performance in High-Tech Manufacturing”, Production and Inventory Management journal, (2000), vol.3, pp.60-65.
- [17] S.S.Chakravorty, “Improving a V-plant operation: A Case Study”, Production and Inventory Management journal, (2000), vol.3, pp.37-42.
- [18] Chandrasekharan Rajendran, Knut Alick, “Dispatching in flow shops with bottleneck machines”, Computers and Industrial Engineering 52, (2007), pp.89–106.
- [19] S Danny J. Johnson “A framework for reducing manufacturing throughput time”, Journal of Manufacturing Systems 4, 2003, pp. 283-298.
- [20] Colin Herron et al. “A methodology for developing sustainable quantifiable productivity improvement in manufacturing companies”, Int. J. Production Economics 104, 2006, pp. 143–153.
- [21] Yumei Hua et al. “Minimizing total completion time in two-machine flow shops with exact delays” Computers & Operations Research Volume36, 2009, pp.2018–2030.
- [22] Goldratt, E.M. (1988), “Computerized shop floor scheduling”, International Journal of Production Research, Vol. 26 No. 3, pp. 443-55.

BIOGRAPHY



Santosh Kulkarni is PG student studying M.E Mech. (Prod) in K I T's College of Engineering, Kolhapur. The topic of his dissertation is Performance Improvement of Production Line.



Mr. Girish R. Naik, Associate Professor Dept of Prod Engg. in K I T's College of Engineering, Kolhapur. M.E.(Mech-Prod.), B.E.(Indl.Prod.), D.C.P, D.B.M, PhD(Pursuing), Academic experience 26 Years, Publications in International journals-28, Publications in national Journals-22