

# Analysis and Optimization of Chain Conveyor Outer Link

S.R.Kale<sup>1</sup>, R.R.Navthar<sup>2</sup>P.G. Student, Department of Mechanical Engineering, PDVVP COE, A. Nagar, Maharashtra India<sup>1</sup>Assistance Professor, Department of Mechanical Engineering, PDVVP COE, A. Nagar, Maharashtra India<sup>2</sup>

**ABSTRACT:** Roller conveyor chains are mostly preferred in production or assembly lines to transport goods as a material handling system. Roller chains have to deal with different environment conditions, chemicals. This causes wear and tear of components of chains and hence unexpected failure and costly production. A conveyor consists of two or more endless strands of chain with attached non interlocking slats or metal flights to carry the material. Other examples are conveying pallets, tree-stumps or even whole cars. Wheeled cars, for example, can be carried by the chain but can also be pulled by the chain. In recent work I have studied the different failures of roller conveyor chain links under different loading conditions using Mild Steel. In chain conveyor system motor capacity of conveyor depends on the weight of chain. It was determined that maximum amount of weight of chain conveyor is covered by outer link and inner link. We concentrated on both link and weight reduction of link by using composite material (Glass Fiber & Carbon Fiber) to reduce the power requirement of conveyor

**KEYWORDS:** Design of chain links; failure cases of chain system; Analysis using ANSYS. Analysis using composite material .

## I. INTRODUCTION

Economy of state is dominated by agricultural as well as industrial sector. Sugar factories play important role in economy of state. About 60 percent processes in these factories are based on roller chain conveyers. Apart from that, other industries also use these chains frequently for process atomization. However, failure of this chain is perennial problem in these industries which causes huge losses to these industries along with its dependants and in turn economical growth of the state. So, roller chain is the most important element of the industrial processes.[1] Roller conveyor chains are generally used in production or assembly lines where individual large objects need to be conveyed. Typical applications of roller conveyors are carrier conveyors for the transport of steel coils in a steel plant or slat conveyors that carry objects. A slat conveyor consists of two or more endless strands of chain with attached non interlocking slats or metal flights to carry the material. Other examples are conveying pallets, tree-stumps or even whole cars. Wheeled cars, for example, can be carried by the chain but can also be pulled by the chain. A typical conveyor chain is constructed with two different types of shackles: the roller link (or inner link) and the pin link (or outer link), see Figure 1.1 The roller link consists of two steel bushings that are press-fitted inside the roller link plates, while the pin link consists out of two steel pins press-fitted inside the pin link plates. To prevent disengaging of plates and pins, riveted pins or t-pins (as shown) are used. Conveyor chains can be loaded in two ways: the force can be applied on the side plates by use of attachments which are connected to the side plates, see Figure 1.1 Alternately the force can be applied on the pins. Therefore hollow pins and axles instead of solid pins (as shown) are used.[1]

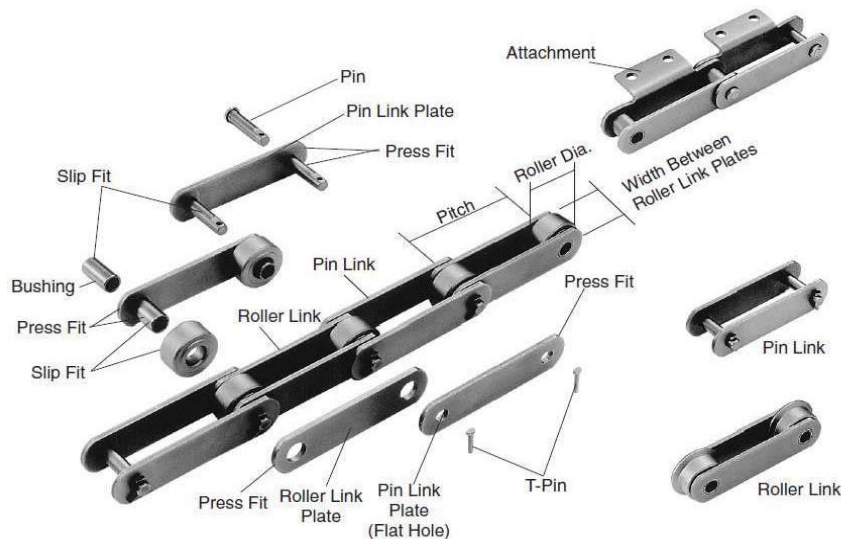

Figure 1.1: Basic structure of a conveyor chain [1]

## II. PROBLEM STATEMENT

The weight of the roller conveyor chain is major problem in industrial sector. The outer link is the important part of the roller conveyor chain assembly. The outer link has the maximum weight contribution in roller chain conveyor assembly. Weight of the outer link has significant weight contribution which makes the roller conveyor chain assembly heavier, hence increases the power required to run the roller chain conveyor. Most of the time chain is under tension which causes failure of chain assembly which is the problem for industrial sector. Causes of this failure are improper design. It is important to study the influence of these parameters. All these parameters can be considered simultaneously and chain link design optimally



FIGURE 2.1 Failure of link

**III.CHAIN CONVEYOR EXAMPLE AND SELECTION**

A suitable type of chain has to be selected for horizontal slat conveyor:

Given values:

Transported material	brown coal
Conveyor length	30 m
Flow	30 T/h
Conveyor conduit width	350 mm
Conveyor conduit height	250 mm
Number of chains	1
Number of teeth of the sprocket	9 (pre-selected)
Load distribution	even

**Corresponding type of chain according to DIN 8167 (ISO 1977) is MRC 80 x 125**

**IV. FEA RESULTS FOR ORIGINAL OUTER LINK**

Figure 5.1 shows the deformation of roller chain conveyor link made of mild steel and Figure 5.2 shows the stresses in roller chain conveyor link made of mild Steel

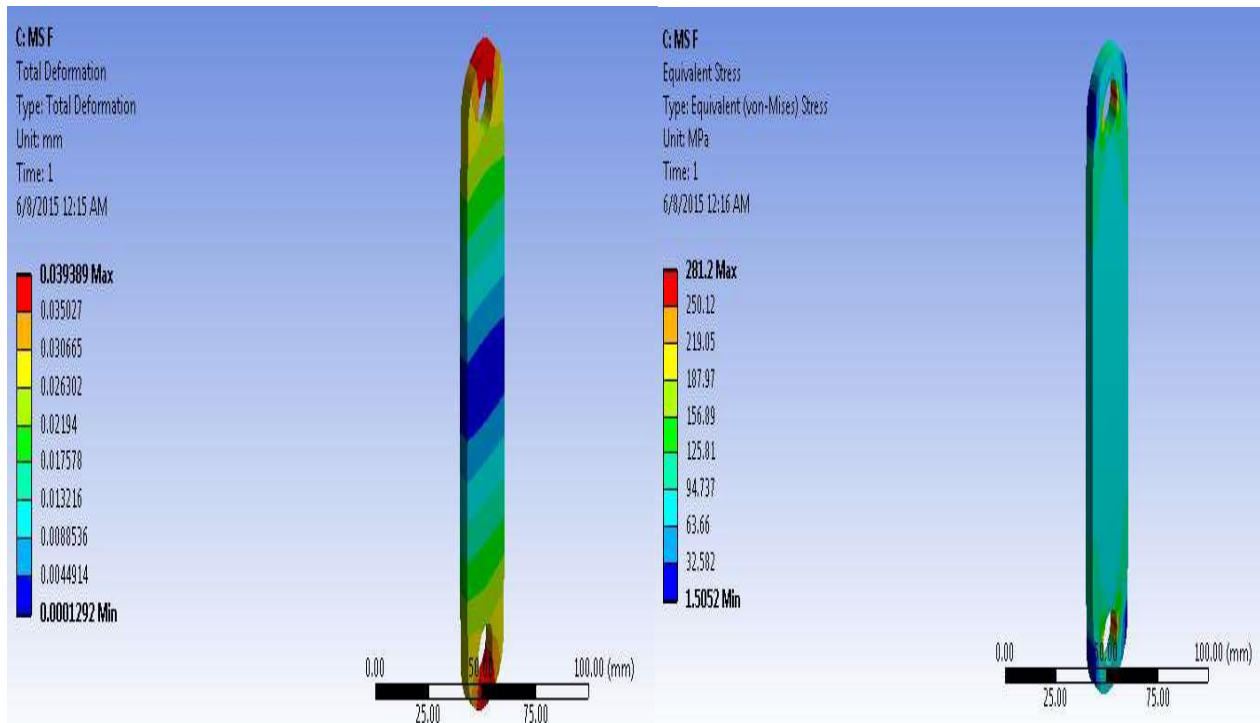

FIGURE 4.1 Deformation of the original Link

FIGURE 4.2 Stresses in the original Link

# International Journal of Innovative Research in Science, Engineering and Technology

(An ISO 3297: 2007 Certified Organization)

Vol. 4, Issue 8, August 2015

## V. FEA RESULTS FOR LINK USING NEW COMPOSITE MATERIAL

Static analysis is performed on the link using new composite materials, Glass Fiber & Carbon Fiber.

Property	Glass Fiber	Carbon Fiber
Young modulus, EX, MPa EY, MPa EZ, MPa	43000 6500 6500	177000 10600 10600
Poisson's ratio, PRX PRY PRZ	0.27 0.6 0.6	0.27 0.2 0.2
Elasticity , GX, MPa GY, MPa GZ, MPa	4500 2500 2500	7600 2500 2500

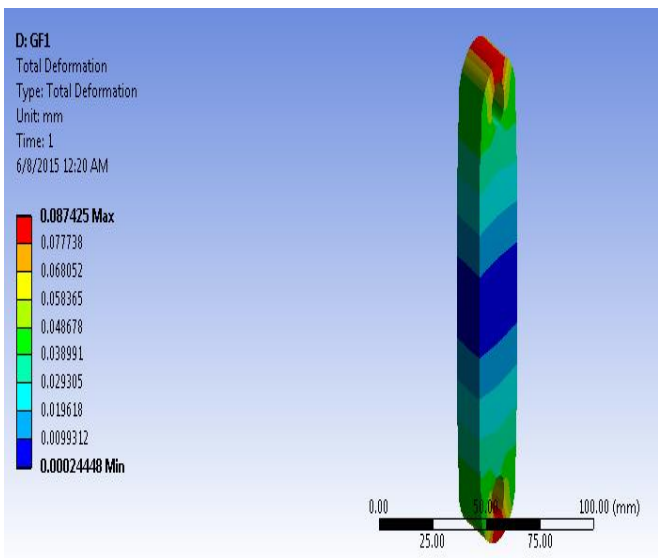

Figure 5.1 Deformation of glass fiber link

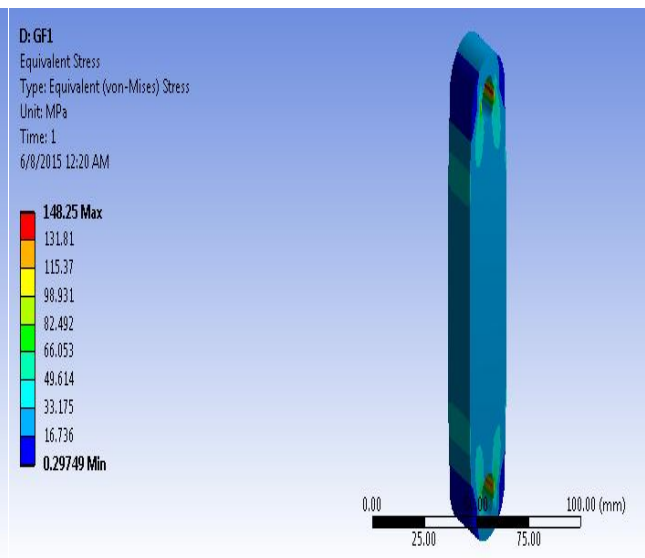

Figure 5.2 stresses in glass fiber link

Figure 5.1 shows the deformation in roller conveyor chain link made of glass fiber. Figure 5.2 shows the stresses in roller conveyor chain link made of glass fiber. Figure 5.3 shows the deformation in roller conveyor chain link made of glass fiber having mild steel bush. Figure 5.4 shows the stresses in roller conveyor chain link made of glass fiber

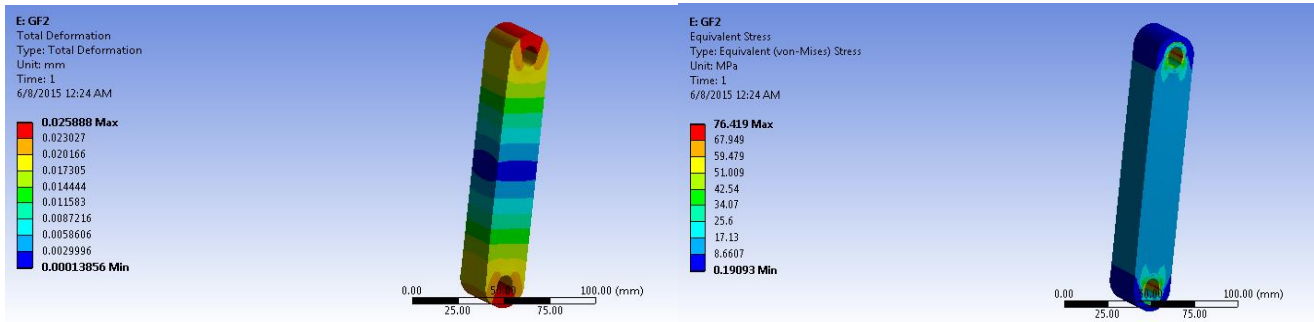

Figure 5.3 Deformation in Glass Fiber with Mild Steel bush      Figure 5.4 Stresses in Glass Fiber with Mild Steel bush

Figure 5.5 shows the deformation in combination of carbon fiber and mild steel (sandwich) Figure 5.6 shows the stresses in combination of carbon fiber and mild steel (sandwich)

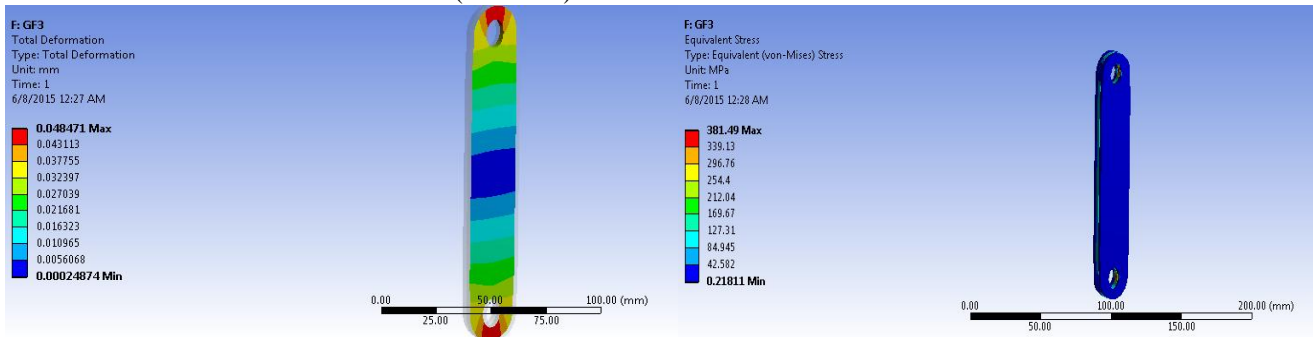

Figure 5.5 Deformation of Glass fiber and Mild Steel (Sandwich)      Figure 5.6 Stresses of Glass fiber and Mild Steel

Figure 5.7 shows the deformation in roller conveyor chain link made of carbon fiber. Figure 5.8 shows the stresses in roller conveyor chain link made of carbon fiber

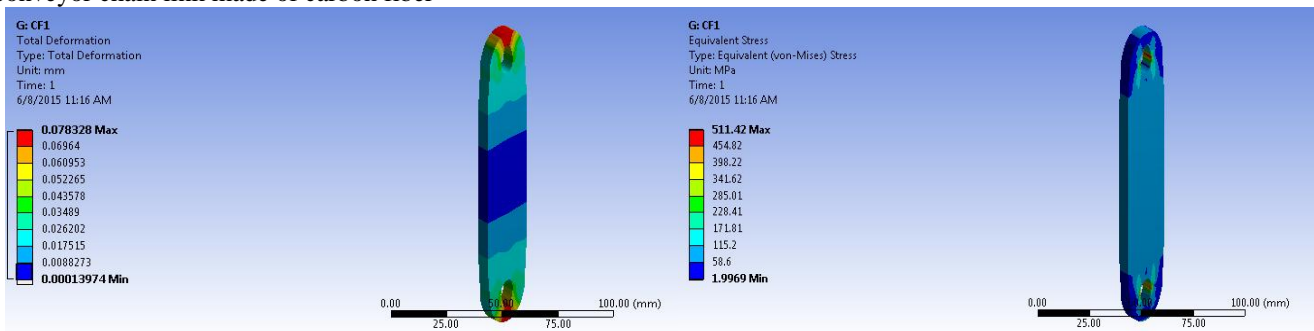

Figure 5.7 Deformation in Carbon Fiber Link      Figure 5.8 Stresses in Carbon Fiber Link

Figure 5.9 shows the deformation in roller conveyor chain link made of glass fiber having mild steel bush. Figure 5.10 shows the stresses in roller conveyor chain link made of carbon fiber with mild steel bush

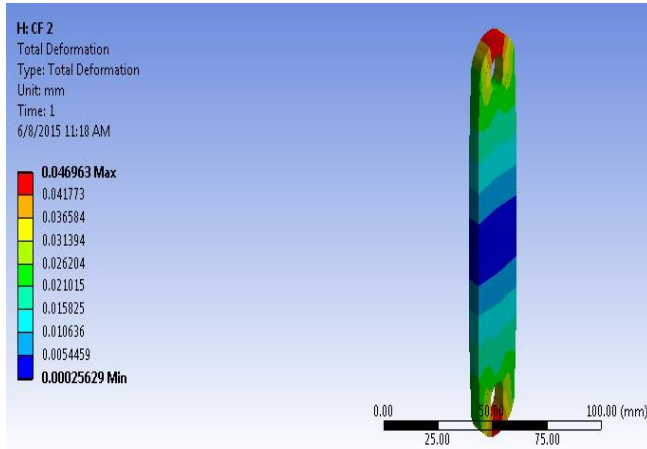

Figure 5.9 Deformation in CF Link with Mild Steel bush

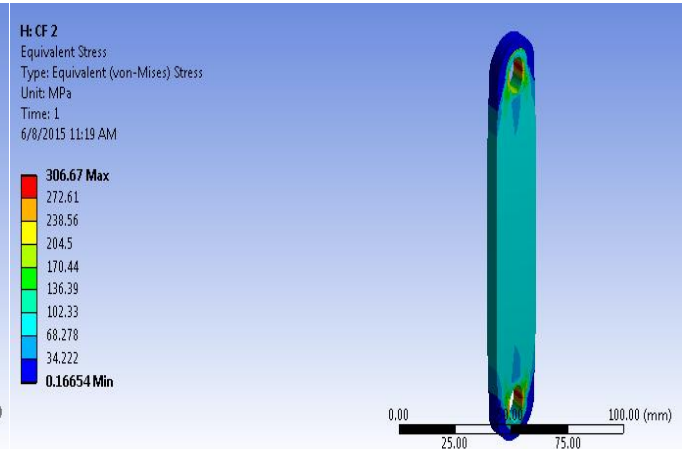

Figure 5.10 Stresses in CF Link with Mild Steel bush

Figure 5.11 shows the deformation of combination of carbon fiber and mild steel (Sandwich). Figure 5.12 shows the stresses in of combination of carbon fiber and mild steel (Sandwich)

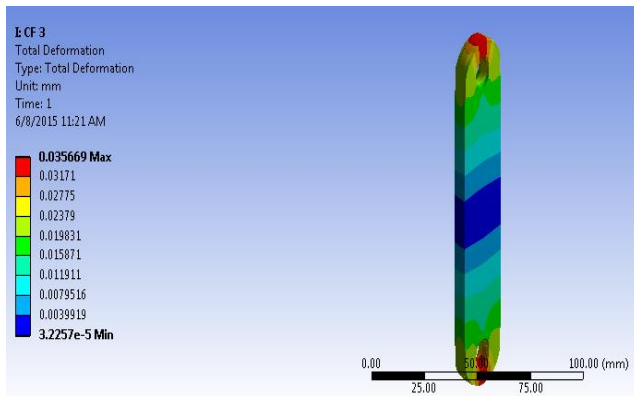

Figure 5.11 Deformation in CF and Mild Steel (Sandwich)

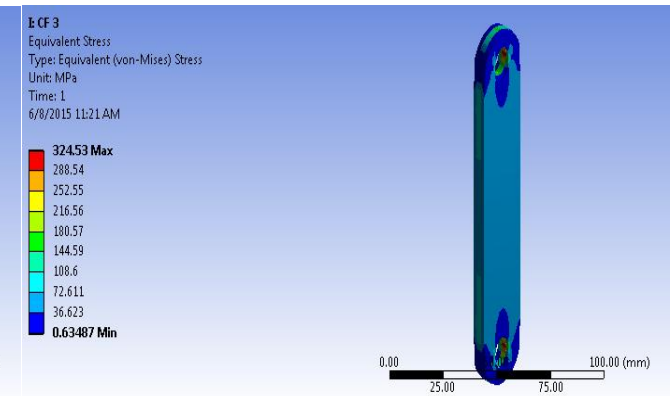

Figure 5.12 Stresses in CF and Mild Steel (Sandwich)

The pure carbon fiber link with 6 mm thickness is having the minimum density and weight but the stresses induced as per the FEA are higher than the stresses induces in the mild steel link. Here we are increasing the thickness by 2 mm to minimize the stresses. Hence the analysis is done of carbon fiber link with 8mm thickness. Figure 5.13 shows the deformation in carbon fiber link with 8 mm thickness.



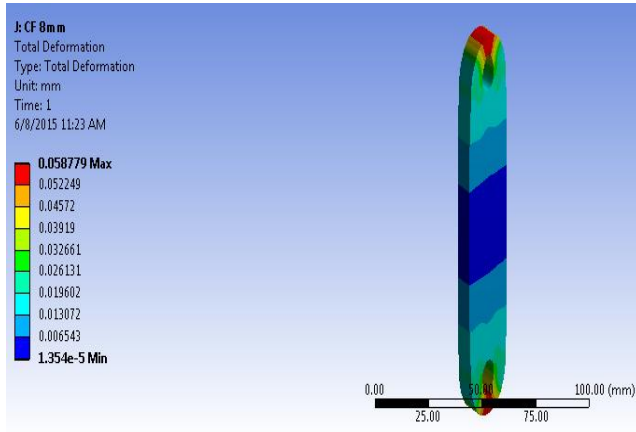

Figure 5.13 Deformation in Carbon Fiber with 8 mm

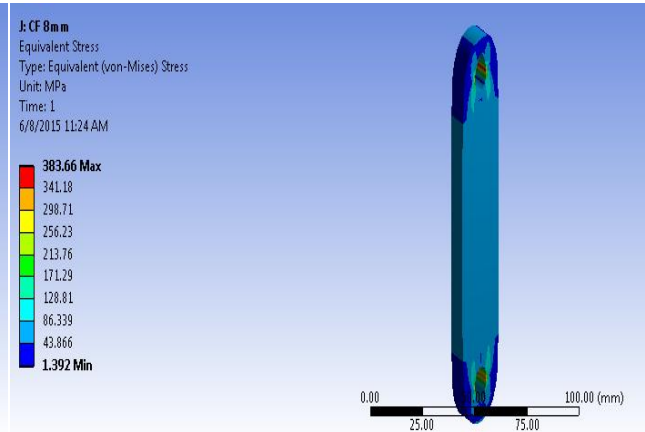

Figure 5.14 Stresses in Carbon Fiber with 8 mm thickness

Figure 5.15 shows the deformation of the carbon fiber link with 10 mm thickness. Figure 5.16 shows the stresses in carbon fiber link with 10 mm thickness

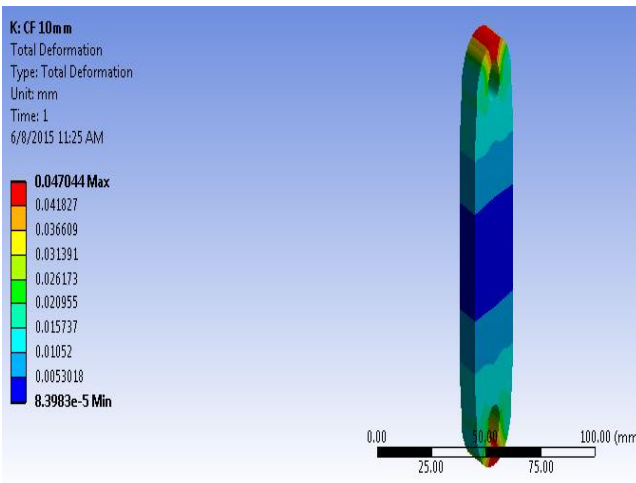

Figure 5.15 Deformation in Carbon Fiber with 10 mm thickness

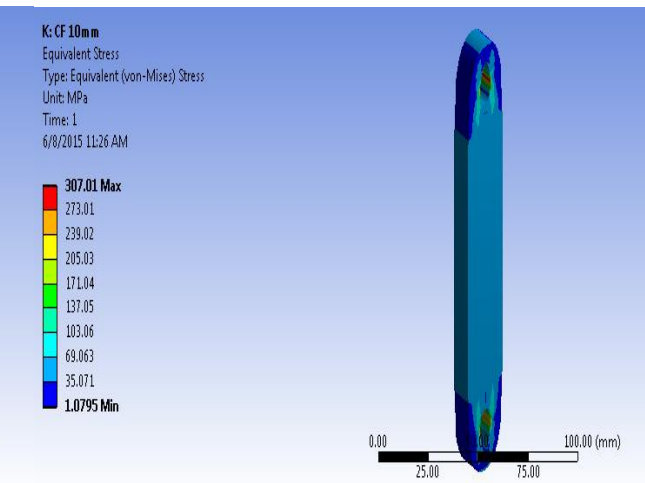

Figure 5.16 Stresses in Carbon Fiber with 10 mm

The stresses induced in the carbon fiber link with 8 mm and 10 mm thickness are higher than the stresses induced in mild steel link. Hence we are again increasing the thickness by 2 mm, and FEA analysis is done with Carbon fiber link having 12 mm thickness. Figure 5.17 shows the deformation of the carbon fiber link with 12 mm thickness

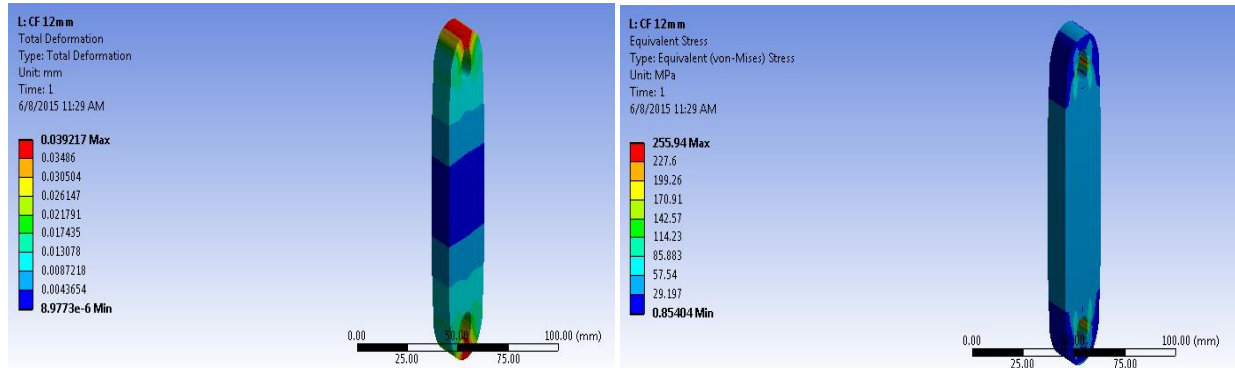

Figure 5.17 Deformation in Carbon Fiber with 12 mm thickness      Figure 5.18 stresses in Carbon Fiber with 12 mm

#### VI. EXPERIMENTAL RESULTS

On the basis of Finite element analysis it is observed that the glass the roller conveyor chain link made of glass fiber is having minimum stresses. For the validation purpose a tension test of glass fiber link is carried out on universal testing machine. Using the attachment the specimen is fixed in universal testing machine. Both the ends are fixed in the universal testing machine.



Figure 6.1 Glass Fiber Specimen



Figure 6.2 Specimens On UTM



# International Journal of Innovative Research in Science, Engineering and Technology

(An ISO 3297: 2007 Certified Organization)

Vol. 4, Issue 8, August 2015



Figure 6.3 Failure Of Glass Fiber Link

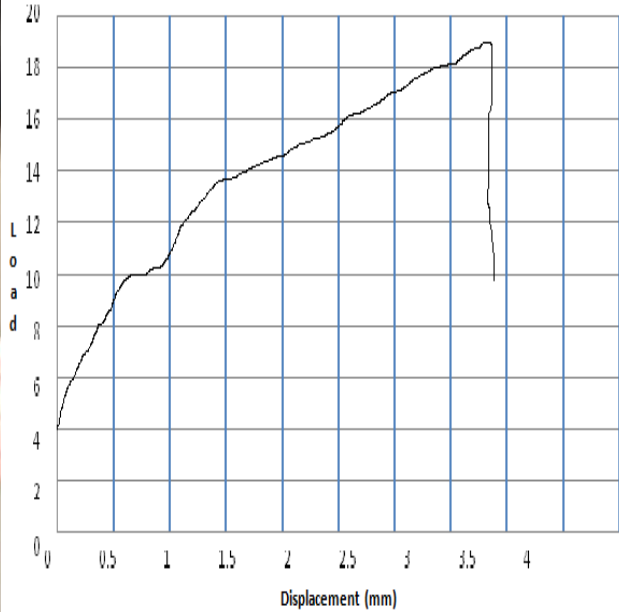

Graph 6.1 Load vs. Displacement

Graph 6.1 shows the graph of load vs displacement. There is no deformation in the glass fiber link up to a load of 4000 N. deformation starts increasing from 4000 N up to a maximum load of 19200 N. With further loading glass fiber link breaks the maximum deformation in the glass fiber link is 3.8 mm. The link is required to take a maximum load of 11600 N which well below the maximum load carrying capacity of glass fiber link.

## VII. RESULTS AND DISCUSSION

SR. NO	Material	Total Deformation (mm)	Equivalent Von Mises Stress (MPa)	Weight (kg)
1	MS	0.03938	281.2	0.13446
2	GF	0.08742	148.25	0.10227
3	GF+MS Bush	0.25888	76.149	0.22077
4	GF+MS+GF	0.04847	381.49	0.10111
5	CF	0.07832	511.42	0.03288
6	CF+MS Bush	0.04696	306.67	0.03656
7	CF+MS+CF	0.03586	324.53	0.09156
8	CF	0.05877	383.66	0.04385
9	CF	0.04704	307.01	0.05481
10	CF	0.03921	255.94	0.06577

# International Journal of Innovative Research in Science, Engineering and Technology

(An ISO 3297: 2007 Certified Organization)

Vol. 4, Issue 8, August 2015

The maximum stress induced in Mild steel link is 281.2 MPa and weight is 0.13446 kg. .FEA is carried out using glass fiber and carbon fiber with different conditions and thickness. The best results are found with glass fiber having thickness 15 mm with 24% weight reduction. The maximum stress induced in glass fiber having 15 mm thickness is 148.25 MPa and maximum deformation is 0.087 mm the carbon fiber link with 12 mm also gives the weight reduction up to 51%.bt glass fiber link is easily available and cheaper in cost which makes itself a good option for using a alternative for mild steel link. Fatigue life of glass fiber link as well as carbon fiber link is higher than the mild steel link. Fatigue life of glass fiber link and carbon fiber link are 1.59e5 and 1.31e5 cycles respectively and that of mild steel link is 8036 cycles at critical sections As per the tension test performed the maximum load carrying capacity of roller conveyor chain link made of glass fiber is 19200 N. The force acting on roller chain link is about 11600 N. hence the load carrying capacity is well above the required force

## VIII.CONCLUSION

Static analysis was performed to achieve the stresses and deformations and in results it is found that there is a maximum deformation of 0.039389 mm in the mild steel link and the Corresponding displacements in glass fiber is 0.087 mm. From the static analysis results, we see that the von-misses stress in the mild steel is 281.2 MPa. And the von-misses stress in glass fiber is 148.25 MPa. Glass fiber link plate can be suggested for replacing the steel link plate from stress and stiffness point of view. A comparative study has been made between steel and composite link with respect to strength and weight. Fatigue life of glass fiber link as well as carbon fiber link is higher than the mild steel link. Fatigue life of glass fiber link and carbon fiber link are 1.59e5 and 1.31e5 cycles respectively and that of mild steel link is 8036 cycles at critical sections. As per the tension test performed the maximum load carrying capacity of the glass fiber link is 19200 N which is well above the requirement. Weight reduction is achieved 24 % with glass fiber, the weight of the glass fiber link is 0.102 kg and that of mild steel link is 0.135 kg. It must be noted that in typical industrial application thousands of such link will be needed. Thus, the weight and material saving will have significant impact on cost of the chain

## REFERENCES

- 1) Bhoite Tushar, Prashant M. Pawar & Bhaskar D. Gaikwad "Fea Based Study Of Effect Of Radial Variation Of Outer Link In A Typical Roller Chain Link Assembly", Ijmie,2012
- 2) M.D Jagtap, Gaikwad B. D, Pawar P. M. "Study Of Roller Conveyor Chain Strip Under Tensile Loading", Ijmer,2014
- 3) Patil Suhas, M. Shinde And R.B. Patil, "Design And Analysis Of A Roller Conveyor System For Weight Optimization And Material Saving", Ijet, 2014
- 4) American Chain Association, Second Edition, "Standard Hand Book Of Chains- Chains For Power Transmission And Material Handling," 2006.
- 5) Reddy, A. V.. "Aeronautical and Engineering Component Failure. United States Of America": Crc Press 2004
- 6) Aliya, D.The" "Failure Analysis Process. An Overview". Materials Park: Asm International 2003
- 7) Bošnjak, S. M., Arsic, M. A., N.Odanovic, Z. D & Dordevic, M. D. (2011). "Failure Analysis of the Stacker Crawler Chain Link .Engineering Procedia", 10: 2244–2249.
- 8) Kerremans, V., Rolly, T., Baets, P. D., Pauw, J. D., Sukumaran, J., & Delgado, Y. P. "Wear Of Conveyor Chains With Polymer Rollers. Sustainable Construction And Design" 2011
- 9) Pankaj Saini, Ashish Goel, Dushyant Kumar, "Design And Analysis Of Compositeleaf Spring For Light Vehicles" Moradabad Institute Of Technology, Moradabad, Uttar Pradesh, India. 2013
- 10) Dakshraj Kothari,Rajendra Prasad Sahu And Rajesh Satankar,, "Comparison Of Performance Of Two Leaf Spring Steels Used For Light Passenger Vehicle", VsrD-Map 2249-8303 Volume2 (1), 9-16.2012