

# International Journal of Innovative Research in Science, Engineering and Technology

(An ISO 3297: 2007 Certified Organization)

Vol. 4, Issue 8, August 2015

## Finite Element Analysis of Axial Flow Fan

M.NagaKiran<sup>1</sup>, T.R.Sydanna<sup>2</sup>, G.Siva Prasad<sup>3</sup>, K.Sagar Kumar, M.Venkateswarlu

Assistant Professor, Department of Mechanical Engineering, Dr.K.V.S.R Institute of Technology, Kurnool, India<sup>1</sup>

Associate Professor, Department of Mechanical Engineering, Sreenivasa. Engineering College, Kurnool, India<sup>2</sup>

Assistant Professor. Department of Mechanical Engineering, Dr.K.V.S.R Institute of Technology, Kurnool, India<sup>3</sup>

Assistant Professor Department of Mechanical Engineering, Dr.K.V.S.R Institute of Technology, Kurnool, India<sup>4</sup>

Assistant Professor Department of Mechanical Engineering, Dr.K.V.S.R Institute of Technology, Kurnool, India<sup>5</sup>

**ABSTRACT:** In this thesis, an axial flow fan is to be designed and modeled in 3D modeling software Pro/Engineer. Present used axial flow fan in the taken application has 10 blades, in this thesis the number of blades are changed to 12 and 8. Theoretical calculations are done to determine the blade dimensions, % flow change, fan efficiency and axial velocity of fan when number of blades is taken as 10, 12 and 8.

The design is to be changed to increase the efficiency of the fan and analysis is to be done on the fan by changing the materials Aluminum Alloy 204, Mild Steel and E Glass. Analysis is done in finite element analysis ANSYS.

**KEYWORDS:** Axial flow fan, Pro/Engineer, Aluminium Alloy 204, Mild Steel, E Glass, ANSYS

### I. INTRODUCTION

The axial flow fans are widely used for providing the required airflow for heat & mass transfer operations in various industrial equipment and processes. These include cooling towers for air-conditioning & ventilation, humidifiers in textile mills, air heat exchangers for various chemical processes, ventilation & exhaust as in mining industry etc.

All the major industries of the national economy such as power generation, petroleum refining & petrochemicals, cement, chemicals & pharmaceuticals, fertilizer production, mining activities, textile mills, hotels etc. use large number of axial flow fans for the aforesaid operations.

The axial flow fans are conventionally designed with impellers made of aluminium or mild steel. The grey area today is the inconsistency in proper aerofoil selection & dimensional stability of the metallic impellers. This leads to high power consumption & high noise levels with lesser efficiency

### II. LITERATURE SURVEY

Young-Kyun Kim [1] et. al Three dimensional flow characteristic was present by a revision of an impeller of an axial turbo fan for improving the air flow rate and the static pressure. To consider an incompressible steady three dimensional flow equations are used as the governing equation and the standard turbulence model is chosen. The pitch angle of  $44^{\circ}$ ,  $54^{\circ}$ ,  $59^{\circ}$  and  $64^{\circ}$  are implemented for the numerical model. The numerical results shows the air flow rates of each pitch angle .the difference of the static pressure at impeller inlet and outlet are 120Pa, 214Pa, 242Pa, and 60Pa according to respective pitch angles. It means that the  $59^{\circ}$  of the impeller pitch is optimal to improve the airflow rate and the static pressure.

Mahajan Vandana N [2] et. al The CFD based investigation has been reported in order to study the effect of change in speed of fan on velocity, pressure, and mass flow rate of axial flow fan. It has been observed that there is a significant change in mass flow rate, velocity of rotor and guide or stator vanes as the speed of the fan is varied. As the performance of the fan is directly dependent on mass flow output. So there should be a moderate velocity and pressure

## International Journal of Innovative Research in Science, Engineering and Technology

(An ISO 3297: 2007 Certified Organization)

Vol. 4, Issue 8, August 2015

profile as all these parameters are correlated .In order to predict the mass flow output, velocity and pressure on stator and rotor section.

### III. TYPES OF AXIAL FLOW FANS

There are three types of Axial Flow Fans are there, they are

#### A. Propeller Fans

These are a special type of axial flow fan used almost exclusively to provide cooling airflow over large finned tube heat exchangers. These fans are often several meters in diameter, they rotate relatively slowly and the blades are usually made from composite material such as Fibre-glass reinforced plastic (FRP), such as those normally used on Cooling Tower fans.



Fig no - .1 Propeller Fan

#### B. Tube Axial Fan

The simplest form of axial flow fans comprising an axial type impeller mounted in a basic cylindrical housing. The impeller is usually mounted directly on the motor shaft and the motor, in turn, is mounted on a folded metal base within the housing. In some cases the fans are belt driven with the motor mounted on a bracket outside the housing.

Tube axial fans have no provision for recovering the residual tangential component of velocity leaving the impeller and are less efficient than other types but this is offset by simplicity and low cost. They have a wide range of application in ventilation and cooling in industrial and commercial buildings, are used in both fixed locations and as portable units. A special case is the jet fan used in vehicular tunnels. In that application, the fans must be certified to continue operation for a limited time in event of a fire where they are exposed to high temperatures.



Fig no – 2 Tube-Axial Fan

## International Journal of Innovative Research in Science, Engineering and Technology

(An ISO 3297: 2007 Certified Organization)

Vol. 4, Issue 8, August 2015

### C. Vane Axial Fan

Vane-axial fans are high efficiency machines that are unmatched in high specific speed (high volume, lower pressure) applications by other fan types. Vane-axial fans have matched downstream stator vanes that convert the tangential component of the velocity leaving the impeller to the axial direction at a higher static pressure and reduced absolute velocity. Effectively this functions as a vaned diffuser although the term is usually reserved for centrifugal machines. In addition long diffusers are often added to improve the overall efficiency, especially on large Mine fans.

Vane-axial types are the most common in higher capacity applications where highest possible efficiency (running costs) outweighs the higher initial capital cost

1. Welded Turning Vanes 2. Dual Belt Tunnel 3. Adjustable motor Plate 4. Extended Lubricating Lines 5. Pre Punched Mount Flanges

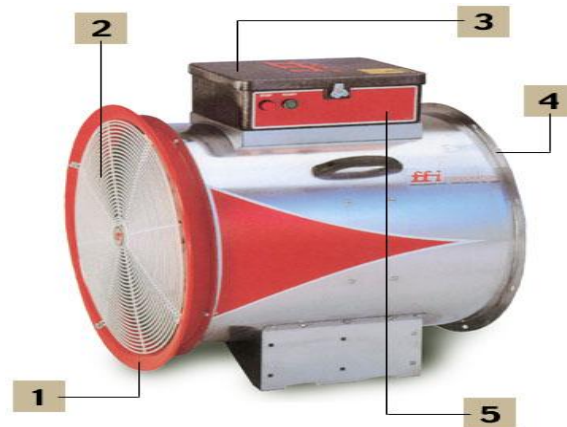

Fig no – 3 Tube-Axial Fan

### IV. THEORITICAL CALCULATIONS FOR 10 BLADES $N_b = 10$ BLADES

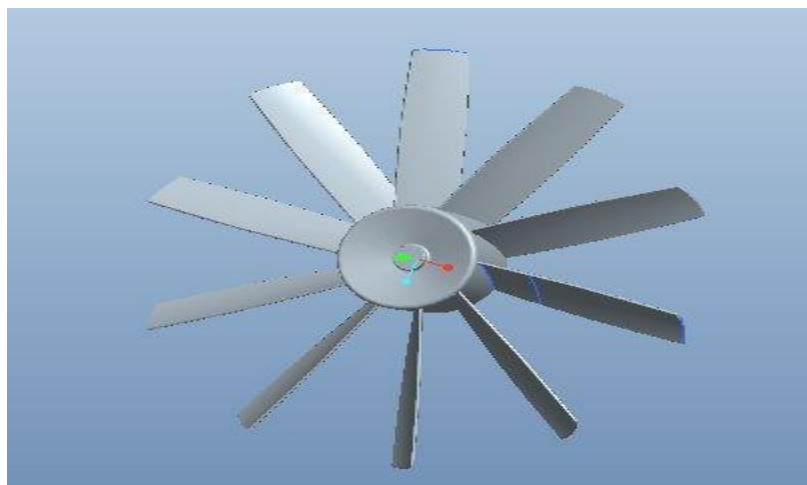

Fig no -4. Blades Model in Pro-E

The Figure-4 is drawn in Pro/Engineering Wildfire 5.0 by using various commands

# International Journal of Innovative Research in Science, Engineering and Technology

(An ISO 3297: 2007 Certified Organization)

Vol. 4, Issue 8, August 2015

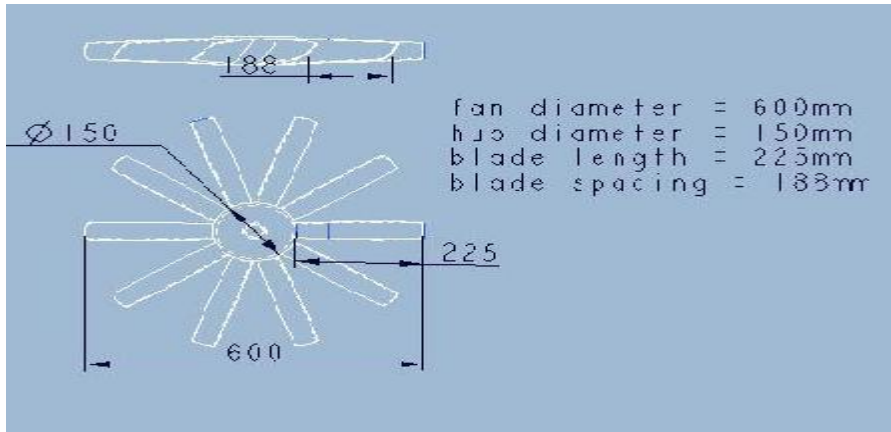

Fig no -5 Dimensions for 10 Blades

Figure-5 shows the dimensions of fan diameter, hub diameter, blade length, blade spacing

- 1) Fan diameter = 600mm Hub diameter (rh) = 150mm Tip radius (rt) = 120mm
- 2) Hub radius/tip radius  $r = (rh / rt) = 75/120$   
 $r = 5/8$   
 $= 0.625$

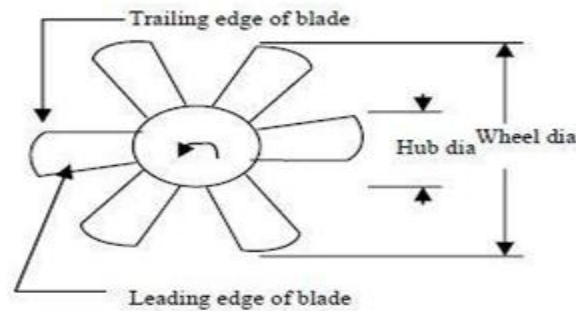

Fig no-6 Basic dimensional parameters

Figure-6 shows the trailing edge of blade, leading edge of blade, wheel dia, and hub dia

- 3) Number of blades (nb) =  $6r/(1-r)$  Where  $r = 5/8$   
 $nb = 10$
- 4) Blades spacing (xp) =  $2\pi R/ nb$  (or)  $\pi R(1-r)/3r$   
R = fan radius = 300mm  
 $xp = 188.4mm$

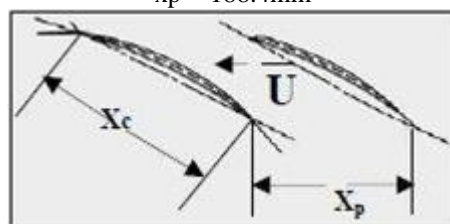

Fig no-7 Chord and Pitch Lengths

# International Journal of Innovative Research in Science, Engineering and Technology

(An ISO 3297: 2007 Certified Organization)

Vol. 4, Issue 8, August 2015

Figure-7 Shows the chord and pitch lengths where  $x_p$ =Blade Spacing

5) Blades width =  $L \leq 3.4 * d / nb$

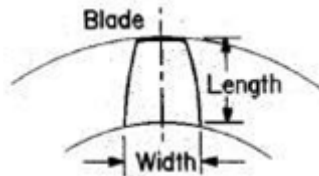

Fig no-8 Blade Length and width

Where  $d$  = hub diameter

$nb$  = no. of blades

$$L \leq 3.4 * 150 / 10 = 51 \text{ mm}$$

6) Blades length =  $(D_{fan} - D_{hub}) / 2$   
 $= (600 - 150) / 2$   
 $= 225 \text{ mm}$

7) Tip speed (ft/min) =  $D * S * \pi / 12$

$D$  = fan diameter in fts

$S$  = speed in rpm

Assume  $S = 1000$  rpm

$$T_s = 512.866 \text{ ft/min}$$

8) Tip clearance = Fan diameter/100  
 $= 600 / 6 = 6$

9) blade passing frequency

$$F_b = F_b = \frac{Nb * rpm}{60} = \frac{10 * 1000}{60}$$

$$= 166.6 \text{ Hz}$$

10) Number of Blades Effect on Fan Noise  
Blade Numbers from 9 to 30

10) Number of Blades Effect on Fan Noise  
Blade Numbers from 9 to 30

$$\% \text{ Flow Change} = \left( \frac{N_2 - N_1}{N_1 + 222} \right) 100$$

Where :  $N_1$  = New Number of Blades

$N_2$  = Original Number of Blades

$$\% \text{ Flow Change} = \left( \frac{12 - 10}{10 + 222} \right) 100 \quad (N_1 = 10; N_2 = 12)$$

$$= 0.862$$

11) Fan efficiency =  $\frac{\text{total pressure rise} * \text{volumetric flow rate}}{\text{shaft power}}$

Total pressure rise = 8.56 mm of water gauge

$$= 8.56 * 9.80664857$$

$$= 83.944 \text{ Pa} \quad (1 \text{ Pa} = 1 \text{ N/m}^2)$$

Volumetric flow rate = 96.94  $\text{m}^3/\text{s}$

Shaft power = 10.1 KW (1 KW = 1000W)

$$1 \text{ W} = 1 \text{ Nm / s}$$

$$= \frac{83.944 * 96.44}{10.1 * 1000}$$

$$= 0.8057 * 100$$

# International Journal of Innovative Research in Science, Engineering and Technology

(An ISO 3297: 2007 Certified Organization)

Vol. 4, Issue 8, August 2015

Fan efficiency = 80.57

12) Axial velocity =  $V_a$

$$V_a = \frac{Q}{\frac{\pi}{4}(D_{fan}^2 - D_{hub}^2)}$$

Q = flow rate here Q is taken from table no: 1.7

$$\text{Axial Velocity} = \frac{96.94}{\pi/4\{(600)^2 - (150)^2\}} = 36.589 \times 10^{-3} \text{ m/s}$$

## V. MATERIAL PROPERTIES ALUMINUM 204.0-T4

### Physical Properties Metric

Density 2.80 g/cc

### Mechanical Properties Metric

Hardness, Brinell 110

Hardness, Knoop 138

Hardness, Rockwell A 44

Hardness, Rockwell B 69

Hardness, Vickers 124

Tensile Strength, Ultimate  $\geq$  331 MPa

Tensile Strength, Yield  $\geq$  200 MPa

@ Strain 0.200

%

Elongation at Break  $\geq$  8.0 %

Modulus of Elasticity 71.0 GPa

Poissons Ratio 0.33

Machinability 90 %

Shear Modulus 26.5 GPa

Shear Strength 199 MPa

### Thermal Properties Metric

Heat of Fusion 389 J/g

CTE, linear 19.3  $\mu\text{m}/\text{m}\cdot^\circ\text{C}$

Specific Heat Capacity 0.963 J/g $\cdot^\circ\text{C}$

Thermal Conductivity 120 W/m-K

Melting Point 529 - 649  $^\circ\text{C}$

Solidus 529  $^\circ\text{C}$

Liquidus 649  $^\circ\text{C}$

### Component Elements Properties Metric

Aluminum, Al 93.3 - 95.5 %

Copper, Cu 4.2 - 5.0 %

Iron, Fe  $\leq$  0.35 %

Magnesium, Mg 0.15 - 0.35 %

Manganese, Mn  $\leq$  0.10 %

Nickel, Ni  $\leq$  0.050 %

Other, each  $\leq$  0.050 %

Other, total  $\leq$  0.15 %

Silicon, Si  $\leq$  0.20 %

Tin, Sn  $\leq$  0.050 %

TITANIUM, Ti 0.15 - 0.30 %

ZINC, ZN  $\leq$  0.10 %

# International Journal of Innovative Research in Science, Engineering and Technology

(An ISO 3297: 2007 Certified Organization)

Vol. 4, Issue 8, August 2015

## VI.STATIC ANALYSIS FOR 10 BLADES USING ALUMINUM ALLOY 204

### Loads:

Pressure – 0.000083944 N/mm<sup>2</sup>

Angular velocity – 0.121963 rad/sec

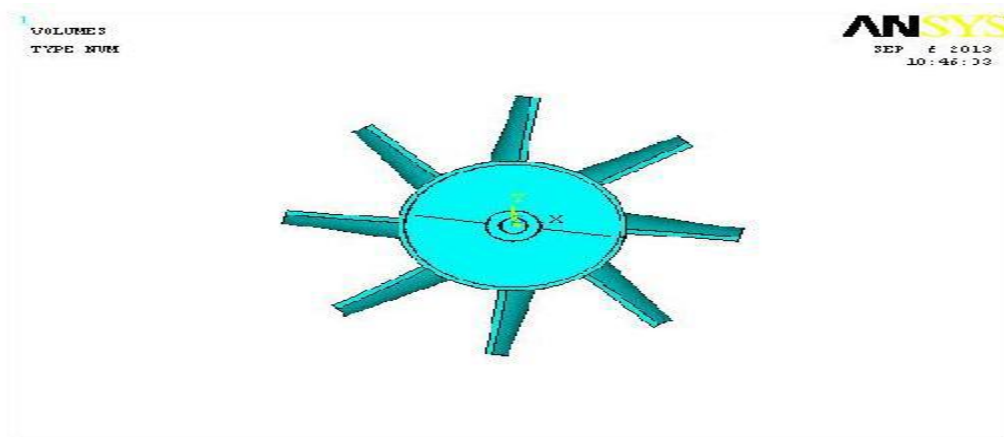

Fig no- 9 imported model from Pro-E

Figure -9 shows the imported model from Pro/Engineering Wildfire 5.0, it must be in Volume

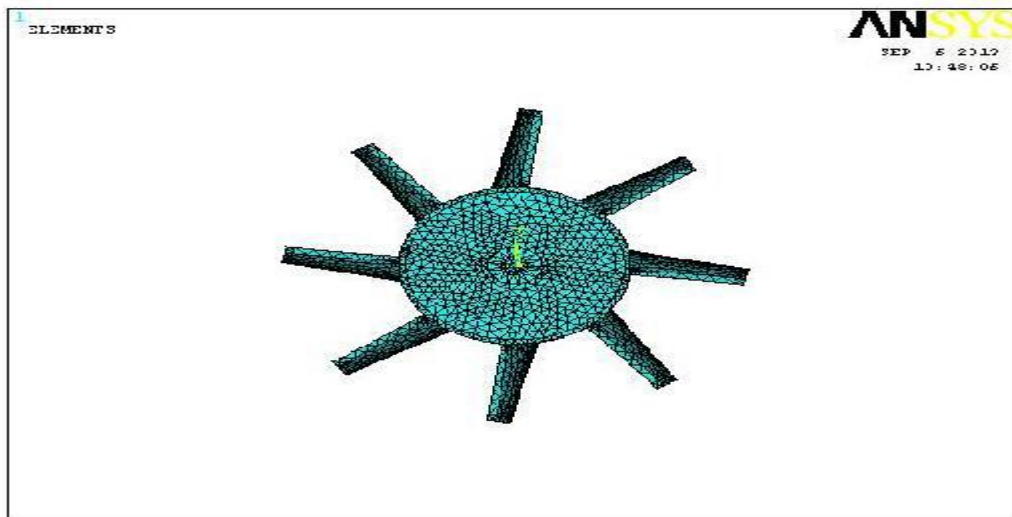

Fig no-10 Meshed model in Ansys

Figure 10 Shows the Meshed Model in ansys 10

# International Journal of Innovative Research in Science, Engineering and Technology

(An ISO 3297: 2007 Certified Organization)

Vol. 4, Issue 8, August 2015

**DISPLACEMENT:**

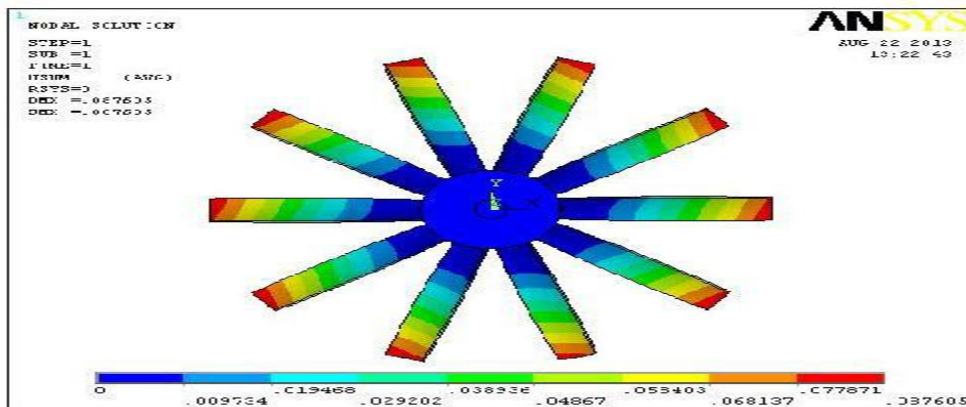

**Fig no -11** Displacement for 10 Blades using Al material property

Figure 11 shows the Displacement for 10 Blades using Aluminum Alloy 204 material property in ANSYS-10

**Stress:**

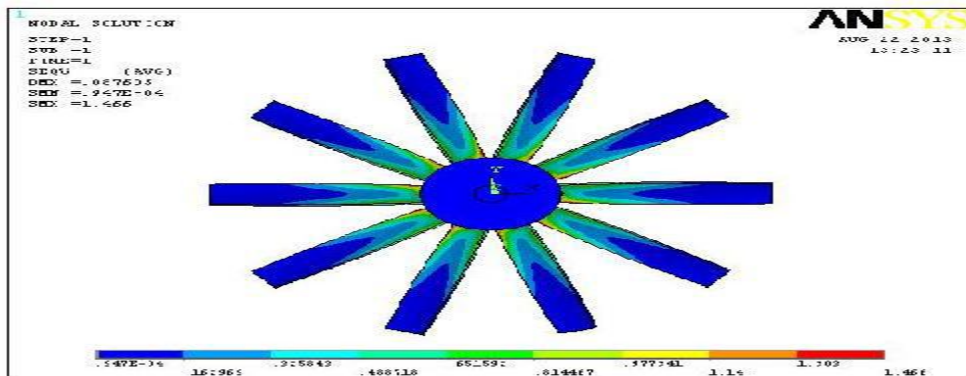

**Fig no -12** Stress for 10 Blades using Al material property

Figure 12 shows the Stress for 10 Blades using Aluminum Alloy 204 material property in ANSYS-10

**Strain:**

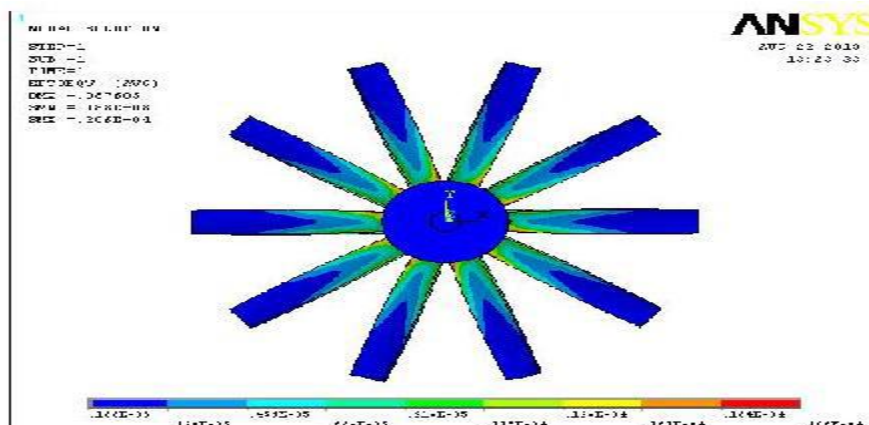

**Fig no-13** Strain for 10 Blades using Al material property



# International Journal of Innovative Research in Science, Engineering and Technology

(An ISO 3297: 2007 Certified Organization)

Vol. 4, Issue 8, August 2015

Figure 13 shows the strain for 10 Blades using Aluminum Alloy 204 material property in ANSYS-10

## VI. DYNAMIC ANALYSIS FOR 10 BLADES USING AL ALLOYS 204

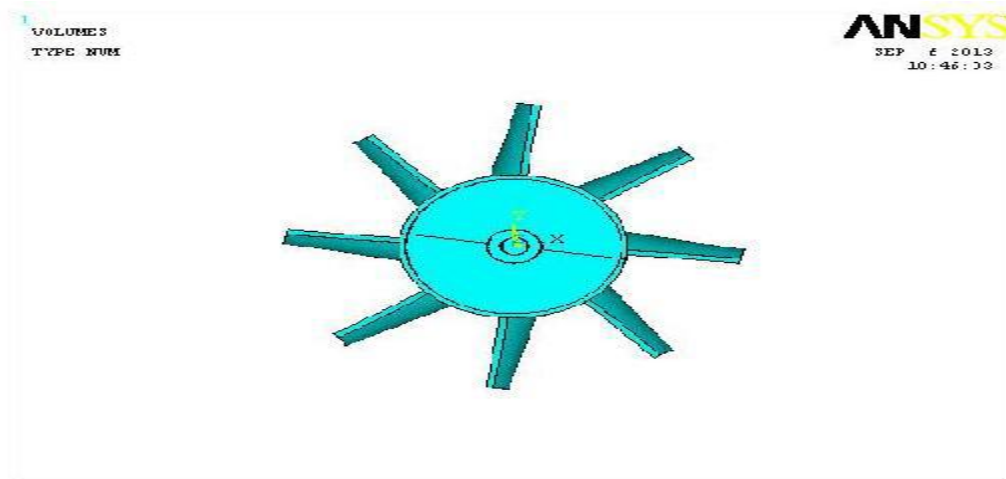

Fig N- 14 Imported model from Pro-E

Figure 14 shows that importing Pro/Engineering 5.0 model in ANSYS 10 it must be in Volumes

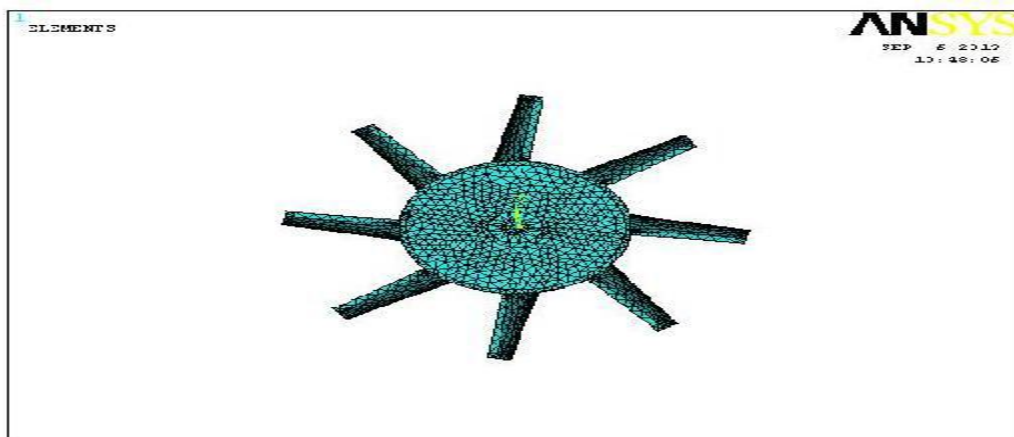

Fig No-15 Meshing model in ANSYS

Figure 15 Shows the meshed model in ANSYS 10 and follows the following steps

### Solution

Solution- analysis type –new analysis – select transient.

Solution controls-

Define these boxes

Time at end of load step - 10

Number of sub steps - 10

Max. No. of sub steps - 10

Min. no. of sub steps – 1

# International Journal of Innovative Research in Science, Engineering and Technology

(An ISO 3297: 2007 Certified Organization)

Vol. 4, Issue 8, August 2015

## Loads

- Define load – apply – structural
- Displacement – on areas – select fixed area.
  - Pressure – 0.000083944 N/mm<sup>2</sup>
  - Angular velocity – 0.263444 rad/sec

## LOAD STEP OPTIONS

LOAD STEP OPTIONS – WRITE LS FILE-1-OK

## SOLUTION

- Analysis type - Solution controls –
  - Define these boxes
  - Time at end of load step - 20
  - Number of sub steps - 10
  - Max. No. of sub steps - 10
  - Min. no. of sub steps - 1

## Loads

- Define load – delete – all load data- all loads & opts
- Define load – apply – structural
- Displacement – on areas – select fixed area.
  - Pressure – 0.000125916 N/mm<sup>2</sup>
  - Angular velocity – 0.263444 rad/sec

## LOAD STEP OPTIONS

Load step options – write LS file-2 – OK

## SOLUTION

- Analysis type - Solution controls –
  - Define these boxes
  - Time at end of load step - 30
  - Number of sub steps - 10
  - Max. No. of sub steps - 10
  - Min. no. of sub steps - 1

## Loads

- Define load – delete – all load data- all loads & opts
- Define load – apply – structural
- Displacement – on areas – select fixed area.
  - Pressure – 0.000167888 N/mm<sup>2</sup>
  - Angular velocity – 0.263444 rad/sec

## LOAD STEP OPTIONS

Load step options – write LS file-3 – OK

## FOR SOLVING SOLUTION

- Solution – solve – from LS file – select
  - Start LS file number - 1
  - End LS file number - 3
  - File number increment - 1
- Select –OK to begin solution

# International Journal of Innovative Research in Science, Engineering and Technology

(An ISO 3297: 2007 Certified Organization)

Vol. 4, Issue 8, August 2015

**DISPLACEMENT:**

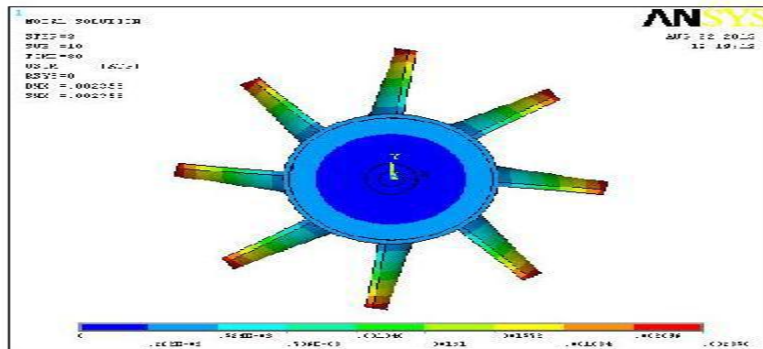

**Fig No 16 - Displacement using 10 Blades with Al Material property in Dynamic analysis**

Figure 16 shows that displacement using 10 blades with Aluminum Alloy 204 material property in Dynamic analysis using ANSYS 10

**STRESS:**

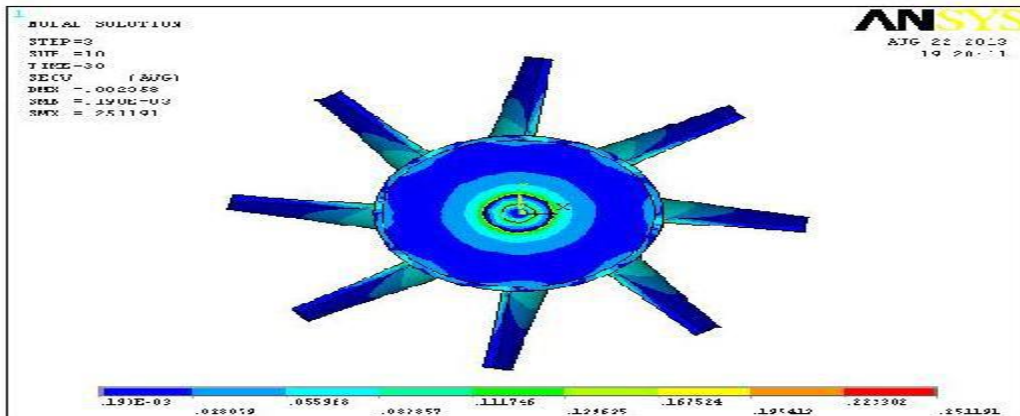

**Fig No 17- Stress using 10 Blades with Al Material property in Dynamic analysis**

Figure 17 shows that Stress using 10 Blades with Aluminum Alloy 204 material property in Dynamic analysis using ANSYS 10

**STRAIN:**

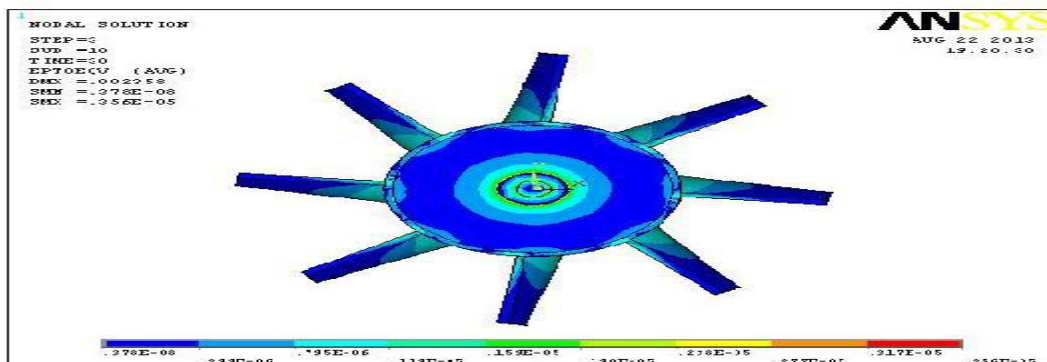

**Fig No 18- Strain using 10 Blades with A Material property in Dynamic analysis**

# International Journal of Innovative Research in Science, Engineering and Technology

(An ISO 3297: 2007 Certified Organization)

Vol. 4, Issue 8, August 2015

Figure 18 shows that Strain using 10 Blades with Aluminum Alloy 204 material property in Dynamic analysis using ANSYS 10

**Note:** By using 8, 10, 12 Blades the Hub Diameter and Blade Length will change. For each and every Blade we are going to check with three material properties like Aluminum Alloy 204, Mild Steel, E-Glass we are going to finalize the best material for best blade by comparing the results with efficiency

## VII. RESULTS & CONCLUSION

### WEIGHT OF AXIAL FLOW FANS (KG)

	MILD STEEL	ALUMINUM ALLOY 204	E GLASS
<b>8 BLADES</b>	14.63	5.07	4.71
<b>10 BLADES</b>	6.91	2.39	2.223
<b>12 BLADES</b>	48.16	16.68	15.497

**Table No: 1-WEIGHT OF AXIAL FLOW FANS (Kg)**

Table -1 shows the weight of axial flow fan for three different types of blades V/s three different materials which are used in this thesis

### THEORETICAL CALCULATIONS

	8 BLADES	10 BLADES	12 BLADES
<b>% OF FLOW CHANGE</b>	13.79	0.862	0.854
<b>AXIAL VELOCITY mm/s</b>	65.861	36.589	23.862

**Table No: 2- THEORETICAL CALCULATIONS**

**Table no -2** shows that the axial velocity and percentage of flow change for three different blades which came from the theoretical calculations

### STATIC RESULTS

#### MILD STEEL

	8 BLADES	10 BLADES	12 BLADES
<b>DISPLACEMENT (mm)</b>	0.737 E <sup>-03</sup>	0.29483	0.002545
<b>STRESS (N/mm<sup>2</sup>)</b>	0.350563	1.492	0.400588
<b>STRAIN</b>	0.166 E <sup>-05</sup>	0.701E <sup>-05</sup>	0.189 E <sup>-05</sup>

**Table No: 3- Static Analysis with Mild Steel**

**Table no -3** shows the static results for mild steel and the Displacement, stress strain values are taken from ANSYS 10.

## International Journal of Innovative Research in Science, Engineering and Technology

(An ISO 3297: 2007 Certified Organization)

Vol. 4, Issue 8, August 2015

### ALUMINUM ALLOY 204

	8 BLADES	10 BLADES	12 BLADES
DISPLACEMENT (mm)	0.001383	0.087605	0.007357
STRESS (N/mm <sup>2</sup> )	0.16944	1.466	0.376155
STRAIN	0.240 E <sup>-05</sup>	0.206 E <sup>-04</sup>	0.532 E <sup>-05</sup>

**Table NO: 4-** Static Analysis with ALUMINUM ALLOY 204

**Table no -4** shows the static results for Aluminum Alloy 204 and the Displacement, stress strain values are taken from ANSYS 10

### E-GLASS

	8 BLADES	10 BLADES	12 BLADES
DISPLACEMENT (mm)	0.001328	0.086858	0.00713
STRESS (N/mm <sup>2</sup> )	0.185617	1.512	0.4046
STRAIN	0.257 E <sup>-05</sup>	0.210 E <sup>-04</sup>	0.563 E <sup>-05</sup>

**Table NO: 5-** Static Analysis with E-Glass

**Table no -5** shows the static results for E-Glass and the Displacement, stress strain values are taken from ANSYS 10

### DYNAMIC RESULTS

#### MILD STEEL

	8 BLADES	10 BLADES	12 BLADES
DISPLACEMENT(mm)	0.001066	0.059943	0.00498
STRESS (N/mm <sup>2</sup> )	0.435849	3.095	0.921093
STRAIN	0.206E <sup>-05</sup>	0.145 E <sup>-04</sup>	0.440 E <sup>-05</sup>

**Table NO: 6-** Dynamic Analysis with Mild Steel

**Table no -6** shows the Dynamic results for Mild Steel and the Displacement, stress strain values are taken from ANSYS 10

### ALUMINUM ALLOY 204

	8 BLADES	10 BLADES	12 BLADES
DISPLACEMENT (mm)	0.002358	0.177895	0.014649
STRESS (N/mm <sup>2</sup> )	0.251191	3.049	0.877972
STRAIN	0.356 E <sup>-05</sup>	0.430 E <sup>-04</sup>	0.126 E <sup>-04</sup>

**Table NO: 7-** Dynamic Analysis with ALUMINUM ALLOY 204

**Table no -7** shows the Dynamic results for Aluminum Alloy 204 and the Displacement, stress strain values are taken from ANSYS 10

# International Journal of Innovative Research in Science, Engineering and Technology

(An ISO 3297: 2007 Certified Organization)

Vol. 4, Issue 8, August 2015

## E-GLASS

	8 BLADES	10 BLADES	12 BLADES
<b>DISPLACEMENT (mm)</b>	0.002275	0.177883	0.01427
<b>STRESS (N/mm<sup>2</sup>)</b>	0.279559	3.176	0.961477
<b>STRAIN</b>	0.387 E <sup>-05</sup>	0.441 E <sup>-04</sup>	0.135 E <sup>-04</sup>

**Table NO: 8-** Dynamic Analysis with E-Glass

**Table no -** shows the Dynamic results for E-Glass and the Displacement, stress strain values are taken from ANSYS 10

## VIII. CONCLUSION

- In this thesis, an axial flow fan is designed and modeled in 3D modeling software Pro/Engineer. Present used axial flow fan in the taken application has 10 blades, in this thesis the number of blades are changed to 12 and 8. Theoretical calculations are done to determine the blade dimensions, % flow change, fan efficiency and axial velocity of fan when number of blades is taken as 10, 12 and 8.
- By observing the theoretical calculations, axial velocity and % of flow change is more when 8 blades are used. The weight of the fan when 12 blades is increased thereby reducing its efficiency. Present used material for fan is Mild Steel, which has more weight. By replacing it with Aluminum alloy 204 and E Glass epoxy, the weight is reduced thereby increasing its efficiency. By using composite material E Glass, the weight is less than Aluminum alloy.
- Structural and Dynamic analysis is done on the fan by changing the materials Mild Steel, Aluminum alloy 204, and E Glass. Analysis is done in finite element analysis ANSYS.
- By observing the analysis results, for all materials, the analyzed stress values are less than their respective yield stress values, so using all the three materials is safe under given load conditions. The strength of the composite material E Glass is more than that of other 2 materials Mild Steel and Aluminum Alloy. By observing the analysis results, the displacement and stress values are less when 8 blades are used.
- So we can conclude that using composite material E Glass and using 8 blades is better.

## REFERENCES

- [1]Young-Kyun Kim,Tae-GuLee, “Flow characteristics Impeller change of an Axial Turbo Fan ” Mechanical Engineering Publications, 37(2), 1984, 476-48.
- [2]Mahajan Vandana N, Shekhawat Sanjay P, “Analysis of Blades of Axial Fan Using ANSYS”, ed. E. Frollini, A.L. Leão and L.H.C. Mattoso, 159-201, 2000, San Carlos, Brazil: Embrapa, USP-IQSC, UNESP.
- [3]Witt & Sohn Ag “Stall and parallel operation” ,83 (12), Journal of Applied Engineering Science,pp.2634-2643.
- [4]Ing.Robin Poul, Doc.Ing Daniel Hanus “Design Optimisation and technology of carbon composite axial flow fan rotor blade of light aircraft propulsion system”, International congress of the aeronautical sciences.
- [5]Imanol Garcia, De Beristain, “Aerodynamic analysis of axial fan unsteady simulations” International journal in research engineering”, Sep 2012
- [6]Thomas Carlous, Marc Schneider “Review of noise prediction methods for axial flow fans”, prepared as paper IN2000/391
- [7]D.Almazo, C.Rodriguez, and M.Toledo “Selection and design of an axial flow fan”, world academy of science, engineering and technology 77 2013
- [8]Railly, J.W., 1984, “Computational Methods in Turbo machinery”, Mechanical Publications, London
- [9]Lakshminarayana, 1996, “Fluid dynamics and heat transfer of turbo machinery”, Wiley Interscience, pp. 358-362.
- [10]Kim, K.Y., Kim, J. Y., and Chung, J.Y., 1997, “Three dimensional analysis of the flow through an axial flow fan”, journal of KSME, Vol.21, No.4, pp.541-542
- [11]Hur, N.K., Kim, U., Kang, S.H., 1999, “A numerical study on cross flow fan: effect of blade shapes on fan performance”, Journal of KFMA, Vol. 2, No. 1, pp.217-222.

## International Journal of Innovative Research in Science, Engineering and Technology

(An ISO 3297: 2007 Certified Organization)

Vol. 4, Issue 8, August 2015

### BIOGRAPHY



**M.NagaKiran** Postgraduate (Machine Design) from RGM Affiliated to JNTU Ananthapuramu 2014. His areas of interest are Design, Composite materials, Finite element Methods.



**T.R.SYDANNA**, Postgraduate (Refrigeration and air conditioning) from JNTU Ananthapuramu in 2003. His areas of interest are Internal Combustion Engines, Heat transfer and Thermal Engineering, operation research, engineering mechanics, Refrigeration and air-conditioning.



**G.SivaPrasad** graduated (Mechanical Engineering) from GPREC Kurnool, SK University, M.Tech (Production Engineering) From SVUCE Tirupathi and His areas of interest thermal engineering, heat transfer and Production engineering.



**K.Sagar Kumar**, graduated (Mechanical Engineering) from GPREC Kurnool, SKD University, M.Tech (industrial management) From NIT Calicut and His areas of interest thermal engineering, strength of material and Production engineering.



**M.Venkateswarlu**, graduated (Mechanical Engineering) from GPREC Kurnool, SK University, M.Tech (Production Engineering) From SVUCE Tirupathi and His areas of interest thermal engineering, Production, Robotics.