

Experimental Investigation of Variation of Temperature in a Four Stroke Spark Ignition Engine

Balaji Rajendiran¹, HariharanElangovan¹, Dineshbabu Deenadayalan²

U.G Student, Velammal Engineering College, Chennai, Tamilnadu, India¹

Assistant Professor, Velammal Engineering College, Chennai, Tamilnadu, India²

ABSTRACT: Heat flux and heat transfer coefficient on the cylinder head is determined with the help of a platinum-platinum rhodium thermocouple with respect to crank angle position by using four stroke single cylinder engine having one inlet and one exhaust valve. The output from the thermocouple is connected with a manual temperature indicator. Results for a certain condition are compared for total heat transfer coefficient of the cylinder engine with experimental measurement and close agreement are observed. It was found that the local value of heat transfer coefficient varies considerably in different parts of the cylinder, but they have equivalent trend with crank angle. Based on the results, new correlations are suggested to predict maximum and minimum convective heat transfer coefficient in the combustion chamber of a SI engine.

I. INTRODUCTION

The combustion chamber walls of an internal combustion engine are subjected to a periodic thermal excitement during the engine cycle. The burned gases instantaneous temperature in the combustion chamber can reach 2500K. The temperature of the metal walls of the combustion chamber as well as the whole material composing the engine has to reach lower levels. This thermal control is guaranteed by the cooling systems. So, these engine running conditions lead to important heat transfers due to temperature gradients of in the all engine structure. Combustion of gas mixture is the main source of heat in the engine. The gas is subjected to different thermodynamic conditions. Between the intake stroke and combustion of mixture, the gas is compressed from the bottom dead centre to the top dead centre. The resulting gas temperature increases is a source of heat transfer from the gas to chamber walls even if there levels are lower than the wall temperature. The heat is transfer from the combustion chamber walls to the fluid. Thus, the description of heat transfer between fluid and walls has to take into account the non-stationary feature of the phenomena during the cycle. The modelling feature of the phenomena during the cycle.

A considerable progress in three dimensional simulations of the turbulent flows has been achieved. However the kinematic and thermal boundary layer is the simulation area where the simplifying hypotheses are most widely used. It is arbitrarily modelled by pre-established laws, said "laws of wall", which do not necessarily correspond to the real flow conditions.

Concerning heat transfer modelling approaches coexist. In conclusion we could say lack of description of fine physics of certain models is compensated by their simplicity.

All the convection models in combustion chamber neglect the precision of simulation during the intake stroke to privilege a validation on the heat transfer peak at the end of the compression stroke. In fact, the major part of the heat transfer is directed from the gas to the walls, especially with combustion, during the cycle. However, because of the influence initial conditions on the development of the physical process such as the combustion, a fine modelling

of the intake stroke seems to be of great interest. If we consider that the chamber walls are

“warm”, intake gases are at low temperature. The intake stroke, coupled with an intense internal aerodynamics, may be responsible of a reheating of gas before the compression stroke. Considering that that the modern engines reach a part of their global performances using internal aerodynamics.

II. LITERATURE SURVEY

F. Alizon et al (2010); this is an experimental approach of the wall heat transfers in the combustion chamber of the internal combustion engine. During compression and the expansion strokes, the correlations for the convection coefficient are mostly used and provide a good estimation of the heat transfers. A bibliographical study shows that the studies having established these formulae never consider the intake stroke precisely. The current constraints for the engine conception bring to conceive evolved aerodynamic strategies during the intake stroke. The question is to know if these very strong and structured aerodynamic structures can modify significantly the characteristics of the convection levels during the intake stroke.

Yuh-YihWua, (2008); the model was developed based on single engine. In order to develop a heat transfer model suitable for more small-scale S.I. engines a heat transfer model also using the Stanton number, which is much simpler but yet accurate enough, is proposed in this paper. The proposed model is determined as a function of compression ratio, stroke, cylinder, volume and mean piston speed. Since the spark plug temperature is required for the proposed heat transfer model, an experimental formula based on two engines is proposed, and determined as a function of intake manifold pressure, engine speed, compression ratio, and throttle opening angle. Experimental data of instantaneous heat flux and global heat transfer of two engines were used to verify the proposed heat transfer model. In addition, the experimental data of cylinder pressure and corresponding heat release rate of three engines were conducted to verify the engine model with the proposed heat transfer model. The results show that the proposed model has better prediction results than the previous one at the most engine operation conditions, thus it can be widely employed for different small-scale engines.

F. Illan, A zero-dimensional combustion model consisting of two zones, coupled with a heat release model has been numerically solved in this paper. A gas mixture model has been used to obtain the influence of working fluid properties on engine performance. The model allows obtaining the in-cylinder temperature and pressure profile, the engine energy balance or the engine temperature map as well as other derived results. The results obtained are in good agreement with other results obtained by previous researchers, proving the ability of the model proposed in this work. Approximately, six minutes have been found as the duration of the transition period from start up in the whole engine, although the piston reaches the regime conditions in less than one minute. Referring to the temperature, the most critical point of the engine has been found in the spark plug and its vicinity, more even than in piston head. Using the model proposed in this work it is relatively simple to analyse further work, the influence of different parameters like cooling medium conditions, engine speed, and combustion characteristics. Finally, using a mesh model more adjusted to engine geometry, the computational cost will increase, but will be possible to analyse the influence of pin geometry on engine temperature distribution.

Hubert Winter et al (2003), CFD simulation has become an indispensable tool for development and optimization of modern large gaseous-fuelled engines. Experimental investigations were executed on a single cylinder research engine. In this regard two different combustion processes were investigated at different loads and compared with simulation results. In addition to comparison of global fuel conversion rates through pressure indication, the local and temporal progress of the flame front was verified through optical measurements of the OH radicals with the help of multiple sensors positioned in the combustion chamber. Gaseous fuelled engines, Charge motion and mixture formation can be simulated with high precision. The behaviour of combustion and wall heat flux is more difficult to represent. The latter were the objects of this investigation. A PDF combustion model and two different wall heat models were tested in detail for their suitability to simulate the phenomena in large gaseous-fuelled engines. Experimental investigations were executed on a single cylinder research engine. In this regard two different combustion processes were investigated at different loads and compared with the simulation results. In addition to the comparison of global fuel conversion rates through pressure indication, the local and temporal progress of the flame front was verified through optical

measurements of the OH radicals with the help of multiple sensors positioned in the combustion chamber. Additional information about flame propagation and an analysis of heat transfer models (logarithmic wall function model and model according to Han & Reitz) were obtained in the pre-chamber and main combustion chamber using local heat flux measurements.

Ravindradas (1989); the present study indicates that the insulation coating applied on the cylinder wall has the following influences. It increases the overall body temperature of the piston. The value of temperature will further increase if the thickness of the insulation coating is increased. With application of a 2-mm thick insulation coating, the reduction in heat loss through the piston is found to be nearly 6%. Heat loss through the air in the crank-case increases but heat loss through the cooling water decreases. The percentage distribution of heat to cooling water and air in the crank-case remains unaffected at high or low loads. The effect of cooling media temperatures is dominant at low loads, while hot gas temperature is dominant at high loads. The temperature fields are obtained by indirect evaluation of the boundary conditions of the piston. The thermal stresses developed in the piston body can be estimated with the help of temperature fields.

Enzo Galloni: Although the RANS approach does not allow to grasp the causes which determine combustion instability, it allows to investigate the factors which influence the extent of cyclic variation in the internal combustion engine. With regard to the engines investigated in this paper, CFD calculations show that the operating points characterized by high cyclic dispersion are characterized by mixtures do not close to the stoichiometric values, low turbulent kinetic energies and very low charge velocities in the spark region at the spark time. The laminar flame speed, turbulence intensity and velocity magnitude have been considered among the factors that affect the extent of the engine cyclic variation. The influence of these parameters has been investigated. Correlating these features of the charge with the measured coefficient of variation in the indicated mean effective pressure, a mathematical relationship has been obtained by means of a multiple regression. This relationship highlights the influence of the considered factors on the extent of the cyclic variation measured in the considered cases: increasing both the laminar flame speed and the turbulence intensity, in the spark-zone at the spark time, the coefficient of IMEP decreases; in the considered cases the mean charge velocity slightly affects the phenomenon. Actually, considering the weight of the early stage of the combustion, the calculated mean values of both the laminar flame speed and the turbulence intensity explain the trends of the measured COVs. Therefore the analysis described in this paper seems to be able to provide guidelines for reducing the cyclic variation of the engine under examination. Thus RANS calculations can be an important tool in indicating optimal solutions regarding the development of this engine in using high EGR ratio or verylean mixtures, i.e. in operative conditions where the combustion stability determines the weak mixture limit tolerable by the engine.

Hugues L. Talom: The exhaust gas from a 2.8L V6 internal combustion engine was used to run a 3 ton absorption chiller which was modified for hot gas intake. The experiments conducted on the system, prove that the concept is feasible, and could significantly enhance system performance depending on part-load of the engine. The concept could be used for refrigeration and air conditioning of transportation vehicles. Further research is needed to establish impacts such as back pressure on the engine, system scalability, reliability, and regulatory issues such as the use of ammonia and lithium bromide on the road. The cost benefit of the added weight, volume, as well as part-load issues not covered above should also be assessed.

G.H. Abd Alia; The present work introduces and simulates the combustion process of a four- stroke naturally aspirated spark ignition engine that result from the analysis of measured cylinder pressure data and that relates the happenings in the combustion chamber to the burning of a real fuel with respect to time. It can be seen that the use of a real combustion curve has a profound influence on the similarity of the pressure-volume profile to that seen for the real engine.

J. HernándezGrau; A systematic and fast procedure has been presented in this paper to identify all the parameters of a single-zone combustion model, which can easily be enlarged to a two-zone combustion model. The combustion heat release is calculated using the polytropic index first law analysis of the pressure data measured in a engine test bench. Woschni's correlation for determining the heat transfer has been verified. The evolution of in-cylinder pressure has been calculated by direct modelling, with the parameters of the model being fitted in accordance with the methodology presented. The results obtained show good agreement.

III. OBJECTIVE AND METHODOLOGY

3.1 Objective of the project

During combustion process approximately 30% of heat only utilized for useful work remaining heat is transfer to the atmosphere as waste. Effective combustion and heat transfer we need to analyse the heat transfer and combustion characteristics of the engine. Depending upon the climatic condition and application the material of the engine or input parameters of engine can be modified for effective heat transfer and for complete combustion.

3.2 Scope of the project

Combustion is an important parameter for knocking in spark ignition engines stoichiometric air- fuel ratio, proper spark timing, and flame propagation are favour for complete combustion.

Heat transfer is an important parameter for thermal efficiency and knocking in air cooled engine, high thermal conductive materials transfer more amount of heat from cylinder to atmosphere. From this analysis we can create a new small scale engine models, and also helpful for developing low heat rejection engines and hybrid engines.

3.3 Methodology

Literature review

- Numerical simulation of combustion chamber models.
- Creating heat transfer models for small scale and large scale spark ignition engines.

Literature analysis

- Analysis of cycle to cycle variation of heat transfer in spark ignition engine.
- Maximum and minimum temperature occurs inside combustion chamber are analysed.
- No of sensors used for measuring base readings.
- Analyse the position for mounting the sensors in the engine.
- LDA or fast response thermocouples are used to measure combustion temperature.

Theoretical study

- Small scale engine type.
- Type of loading suitable for the experiment.
- Adiabatic flame temperature measurement for the engine.
- Temperature range of thermocouples is used to measure heat transfer analysis.

Experimental work

- Calibration of engine for octane fuel.
- Electrical loading coupled with the engine.

- Drilling the engine cylinder head for a diameter 3mm. For mounting the pressure sensor and thermocouples.
- Platinum-platinum rhodium thermocouples are used to measure the combustion, cylinder wall and fin temperatures.
- Adjustable type steel cylinders are use to mount the thermocouples and sensors.
- Installation of thermocouple and sensors.
- A heat transfer characteristic of spark ignition engine is analysed.

IV. COMBUSTION

4.1 Combustion and flame types

- 1) According to Composition of the Reactants
 - a) PREMIXED-Fuel and oxidizer are uniformly mixed together, like in a gasoline engine.
 - b) DIFFUSION-If reactants are not premixed and must mix together in the same region where reaction takes place, the flame is called diffusion.

4.2 Role of combustion chamber on engine performance

The diesel engine performance is greatly affected by the phenomena occurring inside the combustion chamber, which depends mainly on the piston bowl configuration.

- The piston bowl configuration is closely to swirl ratio of the engine.
- In order to maintain the global standard of DI engine performance, multidimensional flow simulation is used as an economical tool for the optimum design of DI engine. Swirl is generated during compression process in DI engine and subsequently it plays a vital role in mixing air and fuel inside the cylinder. Modelling of combustion cylinder and prediction of in-cylinder flow is essential to achieve better performance of a DI engine.

4.3 Types of combustion chamber

1. Open or direct type combustion chamber
2. Pre combustion chamber

4.3.1. Open type combustion chamber

Fuel is injected directly into the upper portion of the cylinder (i.e. combustion chamber). This type depends little on turbulence to perform the mixing.

- High injection pressures and multi-orifice nozzles are required.
- It was used earlier on low speed engines, but with availability of further higher pressures, being used even for high speed engines.

4.3.2. Pre combustion chamber

It is separated into two chambers.

- The smaller chamber occupies about 30 percent of total combustion space.
- As the pre combustion chamber run shot, delay period is very short. This result into small rate of pressure rise and thus, tendency of Diesel knock is minimum, and as such running is smooth.

Products of combustion from pre chamber move to main chamber in a violent way, which helps in a very rapid combustion in third stage due

- Most common
- Produces desirable turbulence
- The deeper the bowl the greater the turbulence
- Lower fuel Inj. Pressures possible
- Shallow bowl less turbulence
- Higher fuel Inj. Pressures required
- Late model engines use Mexican hat because:
- Desirable gas dynamics
- Low risk of fuel burn-out on the piston below the injector
- Long service life

4.4. Combustion chamber design considerations

- Minimal flame travel
- The exhaust valve and spark plug should be close together
- Sufficient turbulence
- A fast combustion, low variability
- High volumetric efficiency at WOT
- Minimum heat loss to combustion walls
- Low fuel octane requirement

4.5. Combustion analysis tools

1. P- θ diagram, Ignition Delay
2. Needle Lift Diagram
3. Line Pressure Diagram

4.5.1. P- θ diagram

Three phases of combustion I. Ignition delay

2. Period of rapid or uncontrolled combustion
3. Period of uncontrolled combustion.
4. After burning

Ignition delay period

- It is defined as the time interval between the start of injection and the start of combustion.
- The delay period is subdivided into physical and chemical delay.
- The period of physical delay is the time between the beginning of injection and attainment of chemical reaction conditions.
- Pressure reached during second stage will depend upon the duration of the delay period.
- Longer the delay period, the more rapid and higher the pressure rise.
- Must aim to keep delay period as short as possible for smooth running to maintain control over the pressure changes.

Period of rapid or uncontrolled combustion

1. This period is counted from the end of delay period to the point of maximum pressure on the indicator diagram.
2. In this rise of pressure is rapid.
3. The rate of pressure rise depends on the amount of fuel present at the end of delay period, degree of turbulence, fitness of atomization and spray pattern.

Period of uncontrolled combustion

1. Temperature and pressure is very high so fuel droplets injected in the stage burn almost as they enter.
2. Pressure rise is controlled by mechanical means i.e. Injection rate.

After burning

Combustion continues even after the fuel injection is over because of poor distribution of fuel particles.

4.5.2. Needle lift diagram

The fuel injected during ignition delay period reduces resulting into less rate of pressure and temperature rise during pre-mixed combustion and thus lower NOX ppm. (This effect is more visible at intermediate speed)

Another advantage: combustion noise reduction.

4.6. Three phases of diesel combustion

- Ignition delay phase (Time between SOI to Start of Combustion)
- Premixed Combustion phase
- Mixing-controlled combustion phase

4.6.1. Ignition delay phase duration responsible for:

- Rate of rise of combustion pressure
- Effects combustion noise
- Peak combustion pressure
- Mechanical stress on components like journal bearing, crank pins & gudgeon pin.
- Peak combustion temp
- NOX generation

4.6.2. Ignition delay is dependent upon:

- Compression Ratio
- Ambient temperature Condition
- Cetane no. of fuel
- Local A/F ratio
- Swirl effect
- Injection pressure
- Load on engine

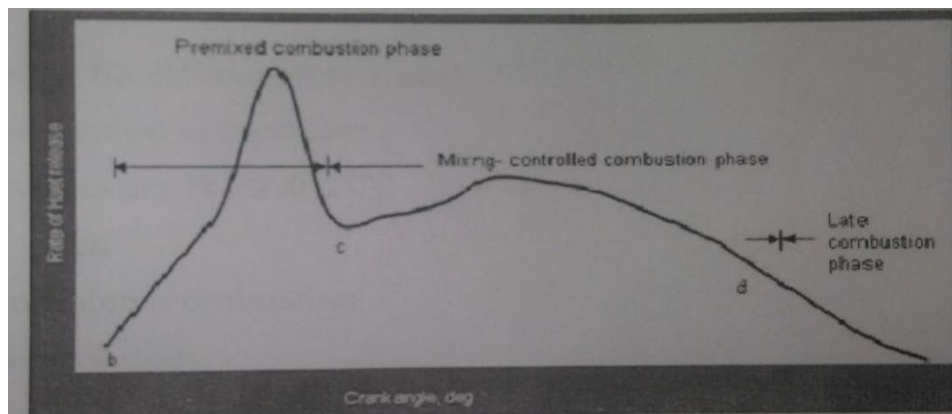

Fig.4.1 Combustion Phase Diagram

Pre-mixed combustion phase (Curve bc): Combustion of a portion of The fuel is injected during the ignition delay period which have mixed with the air in the chemically correct proportion.

Results into,

- Very high rate of cylinder pressure rise resulting into diesel combustion noise.
- Higher combustion temperatures resulting into NOX generation

4.6.4 Mixing Controlled Combustion

- Often referred as Diffusion Combustion
- Represented by curve-cdin figure.
- Depends on the rate fuel mixes with air and acquires a condition.

4.7 Combustion paths

Three types of mixing controlled combustion 1 .Rich

2. Stoichiometric

3 .Lean

1. During Stoichiometric Zones a. Combustion is complete

b. Products are H₂O & CO₂

2. For Rich

a. Incomplete combustion

b. Produces soot

3. For lean

a. Burn ineffectively

b. Produces unburned hydrocarbon

4.8. Factors effecting the combustion process

The factors effecting combustion process are as follows

- 1) Ignition quality of fuel
- 2) Injection pressure of droplet size
- 3) Injection advance angle
- 4) Compression ratio

- 5) Intake temperature
 - 6) Jacket water temperature
 - 7) Intake pressure, supercharging
 - 8) Engine speed.
 - 9) Load and air to fuel ratio
 - 10) Engine size
- I) Types of combustion chamber

4.9. Combustion influence on fuel economy

COMBUSTION INFLUENCE ON FUEL ECONOMY

- The engine cycle efficiency decreases at later injection timings as the heat release shifts away from TDC in this situation. This explains the fuel-consumption and smoke/particulate increase at retarded injection.
- The effect of retard on smoke level, particulate matter and increased fuel consumption can be overcome by using higher fuel injection rates.
- Reducing NOX emissions from about 10.7 to about 4.5g/bhp-hr caused a 6% loss in fuel economy in engine designs from the late 1980s and early 1990s reasons for this loss in fuel economy are attributed to the loss in peak combustion pressure that leads to reduced cycle work.
- A 6% loss in fuel economy is totally unacceptable to the trucking industry, which sometimes survives by virtue of its fuel savings. It is necessary not only to recover but also to improve the fuel economy.
- Effect of injection pressure on fuel consumption:
 1. Increasing injection pressure from 700 to 1000 bar had significant impact on fuel consumption.
 2. Figure shows the effect of injection pressure on fuel consumption at various NOX concentrations.

V. HEAT TRANSFER

5.1 Thermodynamic approach:

This method relies on the input of a measured (or otherwise known) pressure trace to the fundamental thermodynamic calculations and thereby passes knowledge of both the position of the flame front and the burning velocity. A typical example of this method is that described by Lavoie, Heywood and Keck. The thin reaction region is ignored and the combustion space is broken up into two zones, these containing the mass fractions of burnt gas, designated as X_b and that of unburned gas X_u respectively. That this is,

$$X_b + X_u = 1 \quad (5.1)$$

Using subscripts b for the burnt and u for the unburnt sections, the following equations can be obtained.

Average specific volume $V = \text{chamber volume} / \text{mass in chamber} = V/m$

$$= \int_0^1$$

The average temperature in each region is given by:

$$= 1 / \int \tag{5.2}$$

Now multiplying through by the instantaneously uniform combustion pressure p(t),

$$p(t)V/m = R_b T_b x_b + R_u T_u (1-x_b) \tag{5.3}$$

Using first law of thermodynamics, the heat and work transfer can be related to the total internal energy in the combustion chamber.

$$Q - W = U_2 - U_1 = m (u_2 - u_1) \tag{5.4}$$

Where,

$$u_2 = \int_0^1 \tag{5.5}$$

Here Q would be negative as heat is transferred from the system. Now the internal energy can be approximated by assuming specific heat is constant over the temperature range considered, i.e.

$$u_b = C T_b + h \tag{5.6}$$

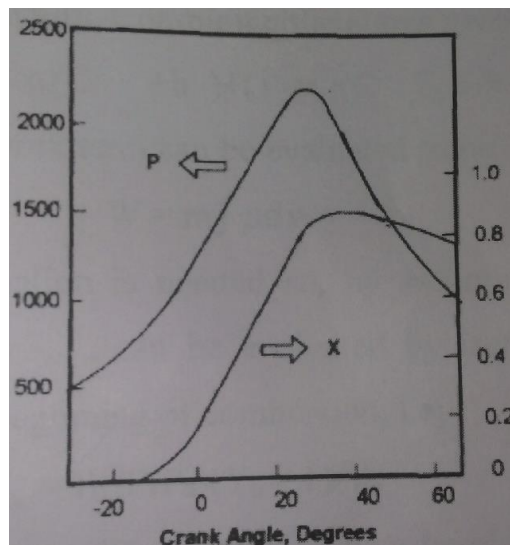

Here, x denotes mass fraction burnt, P denotes Combustion chamber pressure

Fig:5.1 Calculation of mass fraction burnt from a known pressure trace

Dotted line denotes Temperature of first element burnt, Dashed line denotes Temperature of element burnt at x, Continuous line denotes mean temperature of burnt gas

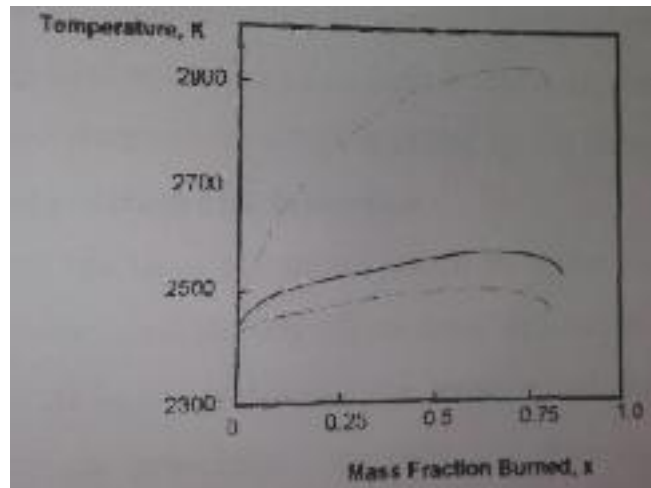

Fig. 5.2 Relationship between temperature of first & current elements of fuel burnt and mean gas temperature

$$u = C T + h \tag{5.7}$$

Here, C, h are constants for the fuel/air mixture in its burned and unburned state respectively and T_b, T are the mean temperatures. Obviously, variable specific heats could be used instead of constant values specified but with an increase in complexity. Combining the above gives:

$$\frac{(+ Q - W)}{m} = (C + h) + (1 -) (C + h) \tag{5.8}$$

If it is assumed that the work term can be evaluated from:

$$= \int \tag{5.9}$$

For solving another equation is needed so, by assuming that the average unburned gas temperature T_u can be evaluated by isentropic compression from the pressure at the beginning of combustion, i.e

$$= (\bar{) (- 1) / \tag{5.10}$$

Hence at any known pressure (t), X_b and T_b may be obtained as function of time. Typical results are shown on the figures. This provides a very useful but simple method for estimating the mean gas temperatures in the two zones. It is essentially assumes that all the burnt gas from instant in the progressive combustion is instantaneously fully mixed with all previously burnt gas. This is a limiting case only. The other limit is that each element of burnt gas retains its individual temperature which is raised by the future compression.

5.2 Heats of reaction and formation

All chemical reactions are accompanied by either an absorption or evolution of energy, which usually manifests itself as heat. It is possible to determine this amount of heat and hence the temperature and product composition from very

International Journal of Innovative Research in Science, Engineering and Technology

An ISO 3297: 2007 Certified Organization

Volume 4, Special Issue 3, March 2015

First National Conference on Emerging Trends in Automotive Technology (ETAT-2015)

Organized by

SAE INDIA Velammal Collegiate Club, Velammal Engineering College, Chennai, India on 20th March 2015

basic principles. Spectroscopic data and statistical calculations permit one to determine the internal energy of a substance. The internal energy of a given substance is found to be dependent upon its temperature, pressure, and state and is independent of the means by which the state is attained. Likewise, the change in internal energy, ΔE , of a system that results from any physical change or chemical reaction depends only on the initial and final state of the system. Regardless of whether the energy is evolved as heat, energy, or work, the total change in internal energy will be the same. If a flow reaction proceeds with negligible changes in kinetic energy and potential energy and involves no form of work beyond that required for the flow, the heat added is equal to the increase of enthalpy of the system

$$= \Delta \tag{5.11}$$

Where Q is the heat added and H is the enthalpy. For a non-flow reaction proceeding at constant pressure, the heat added is also equal to the gain in enthalpy

$$= \Delta \tag{5.12}$$

And if heat evolved,

$$= -\Delta \tag{5.13}$$

Most thermo chemical calculations are made for closed thermodynamic systems, and the stoichiometric is most conveniently represented in terms of the molar quantities as determined from statistical calculations. In dealing with compressible flow problems in which it is essential to work with open thermodynamic systems, it is best to employ mass quantities. Throughout this text uppercase symbols will be used for molar quantities and lowercase symbols for mass quantities. One of the most important thermodynamic facts to know about a given chemical reaction is the change in energy or heat content associated with the reaction at some specified temperature, where each of the reactants and products is in an appropriate standard state. This change is known either as the energy or as the heat of reaction at the specified temperature. The standard state means that for each state a reference state of the aggregate exists. For gases, the thermodynamic standard reference state is the ideal gaseous state at atmospheric pressure at each temperature. The ideal gaseous state is the case of isolated molecules, which give no interactions and obey the equation of state of a perfect gas. The standard reference state for liquids and solids at a given temperature is the real state of the substance at a pressure of 1 atm. Understanding this definition of the standard reference state is very important when considering the case of high-temperature combustion in which the product composition contains a substantial mole fraction of a condensed phase, such as a metal oxide. The thermodynamic symbol that represents the property of the substance in the standard state at a given temperature is written, for example, as HT°, ET° , etc., where the “degree sign” superscript $^{\circ}$ specifies the standard state, and the subscript T the specific temperature. Statistical calculations actually permit the determination of $ET - EO$, which is the energy content at a given temperature referred to the energy content at 0 K. For 1 mol in the ideal gaseous state,

$$= \tag{5.14}$$

$$= + () = + \tag{5.15}$$

This at 0 K reduces to

$$\begin{matrix} & = \\ 0 & 0 \end{matrix} \tag{5.16}$$

Thus the heat content at any temperature referred to the heat or energy content at 0 K is known and

$$(-) = (-) + = (-) + \tag{5.17}$$

0 0 0

The value ($E^0 - E_0^0$) is determined from spectroscopic information and is actually the energy in the internal (rotational, vibrational, and electronic) and external translational degrees of freedom of the molecule. Enthalpy ($H^0 - H_0^0$) has meaning only when there is a group of molecules, a mole for instance; it is thus the ability of a group of molecules with internal energy to do PV work. In this sense, then, a single molecule can have internal energy, but not enthalpy. As stated, the use of the lowercase symbol will signify values on a flame temperatures are calculated for a closed mass basis. Since flame temperatures are calculated for a closed thermodynamic system and molar conservation is not required, working on a molar basis is most convenient. In flame propagation or reacting flows through nozzles, conservation of mass is a requirement for a convenient solution; thus when these systems are considered, the per unit mass basis of the thermo chemical properties is used. From the definition of the heat of reaction, QP will depend on the temperature T at which the reaction and product enthalpies are evaluated. The heat of Reaction at one temperature T0 can be related to that at another temperature T1.

Consider the reaction configuration. According to the First Law of Thermodynamics, the heat changes that precede from reactants at temperature T0 to products at temperature T1, by either path A or path B must be the same. Path A raises the reactants from temperature T0 to T1, and reacts at T1. Path B reacts at T0 and raises the products from T0 to T1. This energy equality, which relates the heats of reaction at the two different temperatures, is written as

$$\left\{ \sum_i [n_i(T_1) - n_i(T_0)] \right\} + \Delta H_{T_1} = \Delta H_{T_0} \quad (5.18)$$

Where n specifies the number of moles of the *i*th product or *j*th reactant. Any phase changes can be included in the heat content terms. Thus, by knowing the difference in energy content at the different temperatures for the products and reactants, it is possible to determine the heat of reaction at one temperature from the heat of reaction at another.

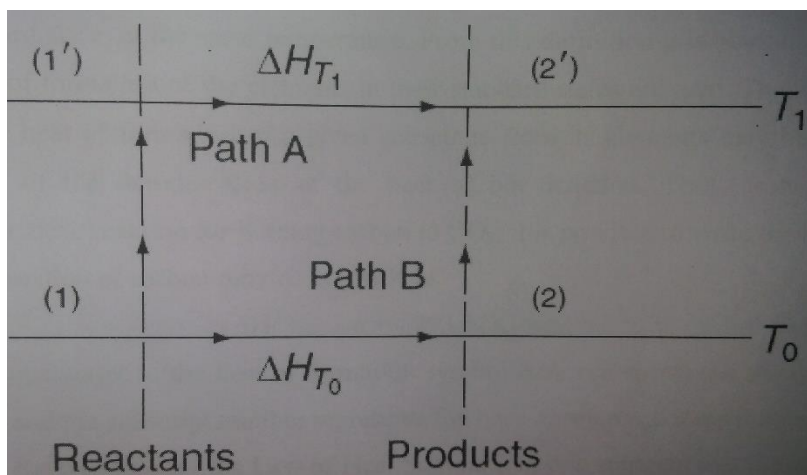

Fig:5.3 Heats of reaction at different base temperature

International Journal of Innovative Research in Science, Engineering and Technology

An ISO 3297: 2007 Certified Organization

Volume 4, Special Issue 3, March 2015

First National Conference on Emerging Trends in Automotive Technology (ETAT-2015)

Organized by

SAE INDIA Velammal Collegiate Club, Velammal Engineering College, Chennai, India on 20th March 2015

If the heats of reaction at a given temperature are known for two separate reactions, the heat of reaction of a third reaction at the same temperature may be determined by simple algebraic addition. This statement is the Law of Heat Summation. For example, reactions can be carried out conveniently in a calorimeter at constant pressure:

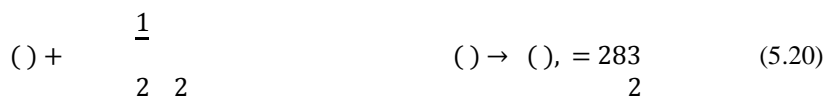

Subtracting these two reactions, one obtains



Since some of the carbon would burn to CO₂ and not solely to CO, it is difficult to determine calorimetrically the heat released by reaction. It is, of course, not necessary to have an extensive list of heats of reaction to determine the heat absorbed or evolved in every possible chemical reaction. A more convenient and logical procedure is to list the standard heats of formation of chemical substances. The standard heat of formation is the enthalpy of a substance in its standard state referred to its elements in their standard states at the same temperature. From this definition it is obvious that heats of formation of the elements in their standard states are zero. The value of the heat of formation of a given substance from its elements may be the result of the determination of the heat of one reaction. Thus, from the calorimetric reaction for burning carbon to CO₂, it is possible to write the heat of formation of carbon dioxide at 298 K as

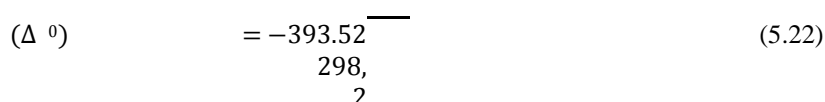

The superscript to the heat of formation symbol ΔH_f represents the standard state, and the subscript number represents the base or reference temperature. From the example for the Law of Heat Summation, it is apparent that the heat of formation of carbon monoxide from Eq. Is

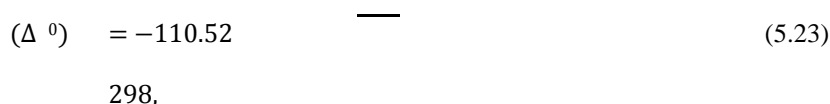

It is evident that, by judicious choice, the number of reactions that must be measured calorimetrically will be about the same as the number of substances whose heats of formation are to be determined. The logical consequence of the preceding discussion is that, given the heats of formation of the substances comprising any particular reaction, one can directly determine the heat of reaction or heat evolved at the reference temperature T₀, most generally T₂₉₈, as follows:

$$\Delta H_r^\circ = \sum \Delta H_f^\circ(\text{products}) - \sum \Delta H_f^\circ(\text{reactants}) \quad (5.24)$$

Extensive tables of standard heats of formation are available, but they are not all at the same reference temperature. The most convenient are the compilations known as the JANAF and NBS Tables, both of which use 298K as the reference temperature. Table 1.1 lists some values of the heat of formation taken from the JANAF Thermo chemical Tables. Actual JANAF tables are reproduced in Appendix A. These tables, which represent only a small selection from the JANAF volume, were chosen as those commonly used in combustion and to aid in solving the problem sets throughout this book. Note that, although the developments throughout this book take the reference state as 298 K, the JANAF tables also list ΔH_f^0 for all temperatures. When the products are measured at a temperature T2 different from the reference temperature T0 and the reactants enter the reaction system at a temperature T0 different from the reference temperature, the heat of reaction becomes

$$\Delta = \sum_2 \left[\left(H_{T_2} - H_{T_0} \right) + \left(H_{T_0} - H_{T_0}^0 \right) \right] + \left(\Delta H_{T_0} \right) - \sum_1 \left[\left(H_{T_0} - H_{T_0}^0 \right) + \left(H_{T_0}^0 - H_{T_0}^0 \right) \right] + \left(\Delta H_{T_0} \right) = - \left(\Delta H_{T_0} \right) \quad (5.25)$$

The reactants in most systems are considered to enter at the standard reference temperature 298 K. Consequently, the enthalpy terms in the braces for the reactants disappear.

The JANAF tables tabulate, as a putative convenience, $(H_T - H_{298})$ instead of $(H_T^0 - H_{298}^0)$. This type of tabulation is unfortunate since the reactants for systems using cryogenic fuels and oxidizers, such as those used in rockets, can enter the system at temperatures lower than the reference temperature. Indeed, the fuel and oxidizer individually could enter at different temperatures. Thus the summation in Eq. is handled most conveniently by realizing that T_0^0 may vary with the substance j. so that the largest positive values of the heats of formation per mole are the highest and those with negative heats of formation are the lowest. In fact, this table is similar to a potential energy chart. As species at the top react to form species at the bottom, heat is released, and an exothermic system exists. Even a species that has a negative heat of formation can react to form products of still lower negative heats of formation species, thereby releasing heat. Since some fuels that have negative heats of formation form many moles of product species having negative heats of formation, the heat release in such cases can be large. Equation shows this result clearly. Indeed, the first summation in

Equation is generally much greater than the second. Thus the characteristic of the reacting species or the fuel that significantly determines the heat release is its chemical composition and not necessarily its molar heat of formation. As explained in Section D2, the heats of formation listed on a per unit mass basis simplifies one's ability to estimate relative heat release and temperature of one fuel to another without the detailed calculations reported later in this chapter and in Appendix I. The radicals listed in that form their respective elements have their heat release equivalent to the radical's heat of formation. It is then apparent that this heat release is also the bond energy of the element formed. Non-radicals such as acetylene, benzene, and hydrazine can decompose to their elements and/ or other species with negative heats of formation and release heat. Consequently, these fuels can be considered rocket monopropellants. Indeed, the same would hold for hydrogen peroxide; however, what is interesting is that ethylene oxide has a negative heat of formation, but is an actual rocket monopropellant because it essentially decomposes exothermically into carbon monoxide and methane. Chemical reaction kinetics restricts benzene, which has a positive heat of formation from serving as a monopropellant because its energy release is not sufficient to continuously initiate decomposition in a volumetric reaction space such as a rocket combustion chamber. Indeed, for acetylene type and ethylene oxide monopropellants the decomposition process must be initiated with oxygen addition and spark ignition to then cause self-sustained decomposition. Hydrazine and hydrogen peroxide can be ignited and self-sustained with a catalyst in a

atomic ratios and the specific atoms that are introduced. It is the atoms that determine what products will form. Only ozone and acetylene have positive molar heats of formation high enough to cause a noticeable variation (rise) in flame temperature. Ammonia has a negative heat of formation low enough to lower the final flame temperature. One can normalize for the effects of total moles of products formed by considering the heats of formation per gram (Δh)_f. The variation of (Δh) among most hydrocarbon fuels is very small. This fact will be used later in correlating the flame temperatures of hydrocarbons in air. One can draw the further conclusion that the product concentrations are also functions only of temperature, pressure, and the C/H/O ratio and not the original source of atoms. Thus, for any C-H-O system, the products will be the same; i.e., they will be CO₂, H₂O, and their dissociated products. The dissociation reactions listed earlier give some of the possible "new" products. A more complete list would be

CO₂, H₂O, CO, H₂, O₂, OH, H, O, O₃, C, CH₄

For a C, H, O, N system, the following could be added:

N₂, N, NO, NH₃, NO⁺, e⁻

Nitric oxide has a very low ionization potential and could ionize at flame temperatures. For a normal composite solid propellant containing, many more products would have to be considered. In fact if one lists all the possible number of products for this system, the solution to the problem becomes more difficult, requiring the use of advanced computers and codes for exact results. However, knowledge of thermodynamic equilibrium constants and kinetics allows one to eliminate many possible product species. Although the computer codes listed in Appendix 1 essentially make it unnecessary to eliminate any product species, the following discussion gives one the opportunity to estimate which products can be important without running any computer code. Consider a C-H-O-N system. For an over oxidized case, an excess of oxygen converts all the carbon and hydrogen present to CO and H₂O by the following reactions:



Where the QP's are calculated at 298 K. This heuristic postulate is based upon the fact that at these temperatures and pressures at least 1% dissociation takes place. The pressure enters into the calculations through Le Chatelier's principle that the equilibrium concentrations will shift with the pressure. The equilibrium constant, although independent of pressure, can be expressed in a form that contains the pressure. A variation in pressure shows that the molar quantities change. Since the reactions noted above are quite endothermic, even small concentration changes must be considered. If one initially assumes that certain products of dissociation are absent and calculates a temperature that would indicate 1% dissociation of the species, then one must re-evaluate the flame temperature by including in the product mixture the products of dissociation; that is, one must indicate the presence of CO, H₂, and OH as products. Concern about emissions from power plant sources has raised the level of interest in certain products whose concentrations are much less than 1%, even though such concentrations do not affect the temperature even in a minute way. The major pollutant of concern in this regard is nitric oxide (NO). To make an estimate of the amount of NO found in a system at equilibrium, one would use the equilibrium reaction of formation of NO



International Journal of Innovative Research in Science, Engineering and Technology

An ISO 3297: 2007 Certified Organization

Volume 4, Special Issue 3, March 2015

First National Conference on Emerging Trends in Automotive Technology (ETAT-2015)

Organized by

SAE INDIA Velammal Collegiate Club, Velammal Engineering College, Chennai, India on 20th March 2015

2

2

As a rule of thumb, any temperature above 1700 K gives sufficient NO to be of Concern. The NO formation reaction is pressure-insensitive, so there is no need to specify the pressure.

If in the over oxidized case $T_2 > 2400$ K at $P = 1$ atm and $T_2 > 2800$ K at $P = 20$ atm, the dissociation of O₂ and H₂ becomes important; namely,

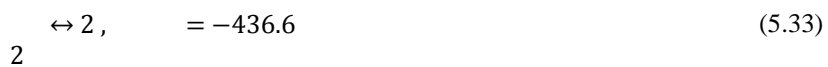

Although these dissociation reactions are written to show the dissociation of one mole of the molecule, recall that the ΔH_f° 's are written to show the formation of one mole of the radical. These dissociation reactions are highly endothermic, and even very small percentages can affect the final temperature. The new products are H and O atoms.

Actually, the presence of O atoms could be attributed to the dissociation of water at this higher temperature according to the equilibrium step

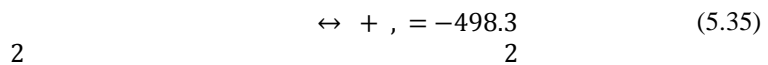

Since the heat absorption is about the same in each case, Le Chatelier's principle indicates a lack of preference in the reactions leading to O. Thus in an over oxidized flame, water dissociation introduces the species H₂, O₂, OH, H, and O. At even higher temperatures, the nitrogen begins to take part in the reactions and to affect the system thermodynamically.

At $T > 3000$ K, NO forms mostly from the reaction



Rather than

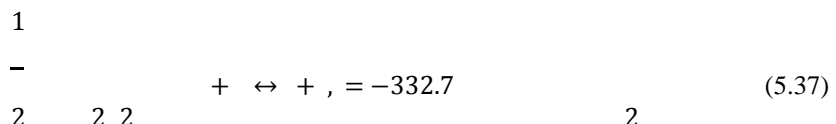

If $T_2 > 3500$ K at $P = 1$ atm or $T_2 > 3600$ K at 20atm, N₂ starts to dissociate by another highly endothermic reaction:

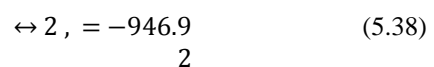

Thus the complexity in solving for the flame temperature depends on the number of product species chosen. For a system whose approximate temperature range is known, the complexity of the system can be reduced by the approach discussed earlier. Computer programs and machines are now available that can handle the most complex systems, but sometimes a little thought allows one to reduce the complexity of the problem and hence the machine time. Equation is now examined closely. If the n_i 's (products) total a number μ , one needs $(\mu + 1)$ equations to solve for the n_i 's and

Table 6.1 Engine specification

Engine Specification	
Model	C12
Fuel	Petrol start kerosene run engine
Type	Four Stroke, Air cooled, Single cylinder engine
Bore	55mm
Stroke	50mm
Capacity	120cc
Power rating	1.95Bhp @ 3000rpm(HSP), 1.5Bhp @3000rpm(HSPP)
Lubricating Oil	SAE 20W 40 Oil sump capacity 0.57 litre (1 pint) Ignition system Electronic Fuel Petrol start
Dry weight	17.5 kg

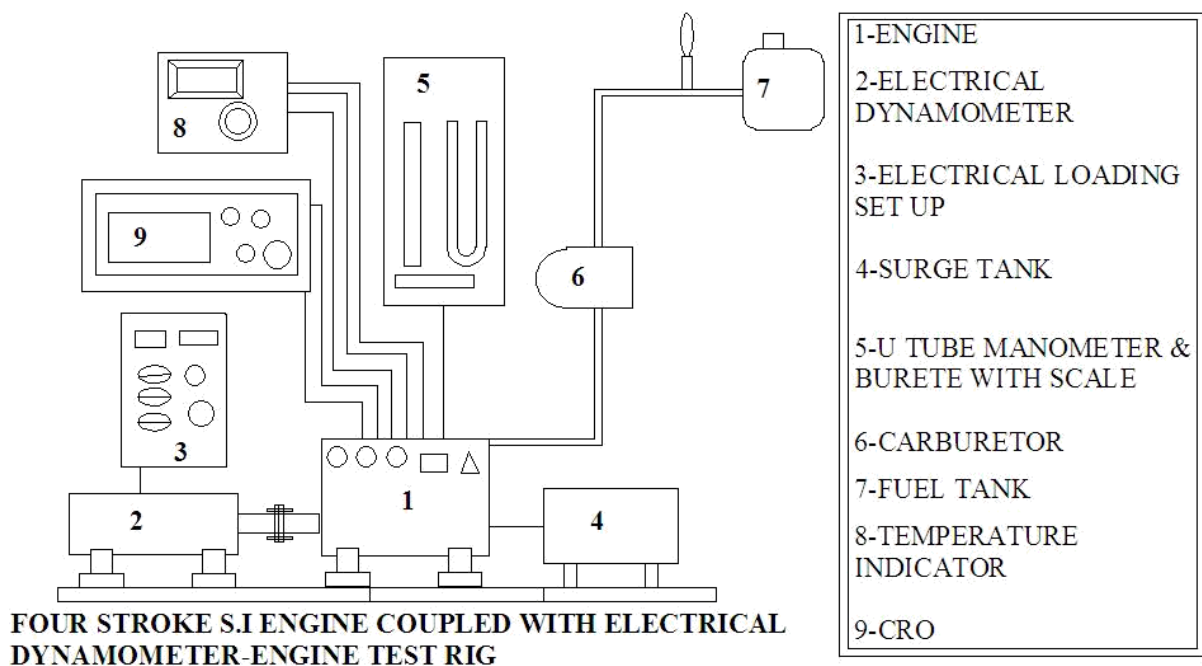

Fig 6.2 Schematic Diagram of experimental setup

6.3 Heat flux measurements

We want to measure heat flux in gas-wall interface of the combustion chamber. This heat flux is of convective origin. Nevertheless, this heat transfer is a conduction phenomenon; conductive heat transfer in the thermal boundary layer of fluid and, by continuity, conduction in the cylinder wall. The establishment of heat transfer by conduction is a result of temperature gradient. Thus, the question is to know whether we measure this gradient in the fluid or in the metal cylinder. The methods of precise measurement in a fluid flow, particularly very close to the wall, are too complex or even practically non-existent in the hostile environment of the combustion chamber. Therefore, the chosen method consists in measuring the temperature gradient between a point of the internal cylinder surface and a fixed point at a known distance normal to the wall in the cylinder material. By derivation according to Fourier's law, we obtain a heat flux surface density. According to different theoretical heat transfer studies, we may assume that the non stationary heat transfer in the cylinder liner is one dimensional.

6.4 Thermocouple

Platinum- platinum Rhodium thermocouple

The thermocouple having precision within $\pm 20\text{mK}$ at 1100°C and $\pm 50\text{ mK}$ at 1300°C . The thermocouple is used to measure the combustion, cylinder wall temperatures in the spark ignition engine.

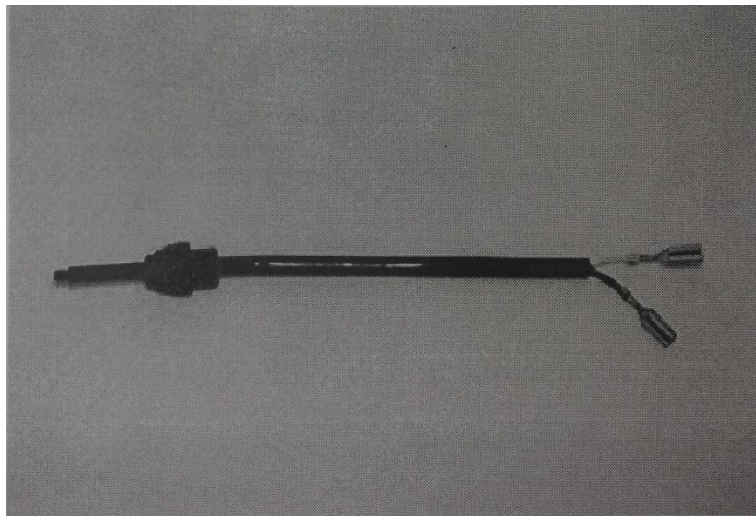

Fig.6.3 Platinum-platinum rhodium thermocouple

Thermocouples employing platinum in combination with platinum- platinum rhodium alloys, gold or palladium have been found to be the most reproducible of all the various types.

The Pt 13Rh/Pt (or type R, or 13/0) thermocouple is very similar in its properties to the type S; containing 13% Rh by weight, it has a little higher sensitivity and probably also little higher reproducibility.

As the melting point of platinum-platinum rhodium thermo elements increases with increasing rhodium content are relatively more stable to higher limits of temperature. The 40/20 thermocouple is useful for accurate measurements up to 1850 oc and is superior to type B. Which one is chosen for measurements from 1500 to 1700 oc would have to be based on total temperature range, the duration of the measurements, the availability of the thermo elements, and the importance of the magnitude of the thermo electric Power for the user's measuring equipment.

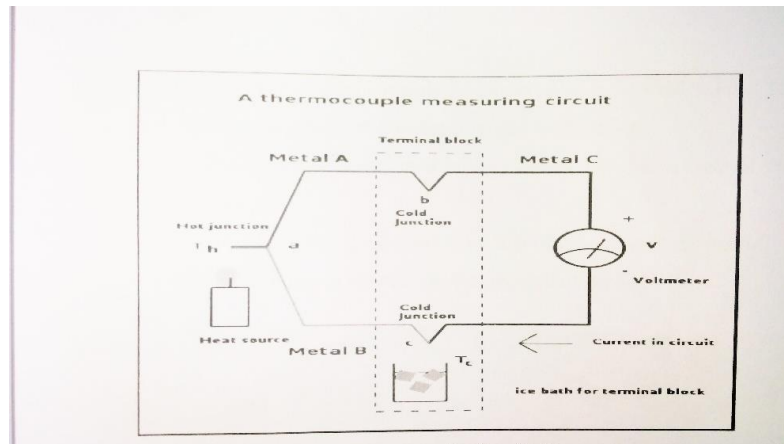

Fig. 6.4 Thermocouple circuit diagram

6.5 Probe performance

The engine cycle involves fast changes of the gas thermodynamics conditions with simultaneous variations of the liner surface temperature. Our objective is to provide precise measurements of this non stationary thermal constraint. The detailed principle of heat flux sensors is as follows: the first electrical element is (platinum) is a 0.5mm diameter cylinder. The second element (platinum-rhodium), which forms the body of the sensor, is a co axial 2.5 mm diameter cylinder surrounding first element these two elements are electrically isolated by an aluminium oxide coating (5 micrometers). At the end of these two cylinders, a conductive metal deposit ("thin film") realizes the connection of the temperature sensor that the thickness is 10 micrometers. By this mounting, we obtain a respond time between 10 and 15 microseconds (approximately 0.07CA at 1200 rpm) concerning heat flux. Five thermocouples are used for measure the heat transfer from the combustion gases to the atmosphere.

- The first thermocouple is mounted in the combustion chamber for measuring the adiabatic flame temperature.
- The second thermocouple is mounted in the cylinder liner for measuring the heat transfer from gas to the metal.
- The third one is mounted in the cylinder head or in base of the fin.
- The fourth one is mounted in middle of cross section of the fin.
- The fifth one is mounted in the free end of the fin.



Fig.6.5 Combustion chamber of engine

6.6 Installation conception of the flux meters:

The installation conception of the sensors has to respond to a requirement of measurement precision and to a coherence of the experimental methods. These last ones have been chosen with the motive to make simultaneous measurements of velocity close to the wall and of heat flux. Three possible areas in the combustion chamber: the position crown, the cylinder head and liner. Because of its flatness and its being permanent contact with the gas in the chamber, the piston crown was at first of great because of its flatness and its being permanent contact with the gas in the chamber, the piston crown was at first of great interest.

Nevertheless, it is a moving piece, which would have made the temporal velocity measurement close to the wall, optimally too complex. So here we choose to mount the thermocouples in the cylinder head.



Fig. 6.6 Complete experimental setup

VII. RESULTS AND DISCUSSION

TABLE 7.1 LOAD VS TEMPERATURE DISTRIBUTION

LOAD (AMPS)	T1(°C)	T2(°C)	T3(°C)	T4(°C)	T5(°C)
0	1382	859	374	82	74
2	1620	974	386	92	69
4	1796	1093	393	86	74
6	1950	1152	395	93	78
8	2150	1024	410	95	81

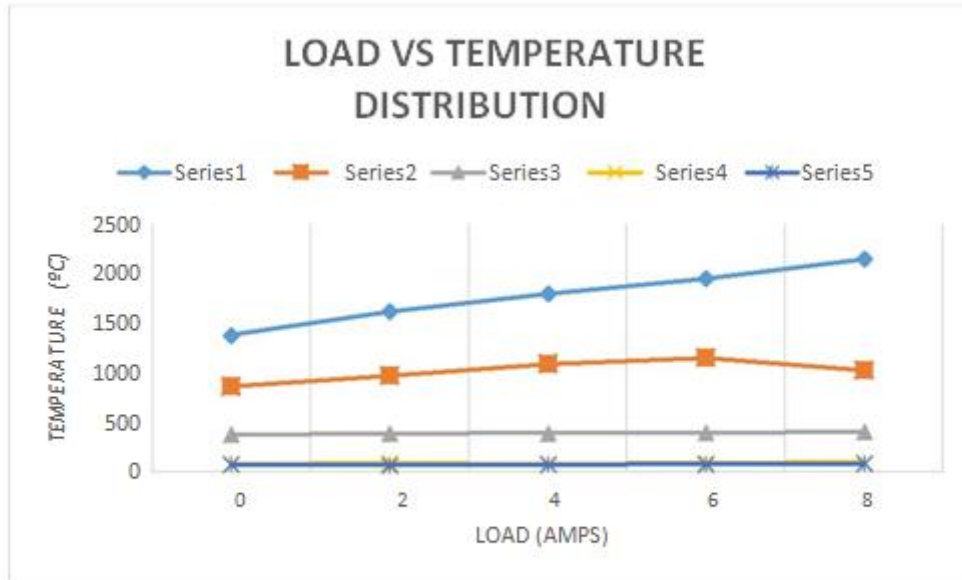

Fig 7.1 Load Vs Temperature

Table7.2 Load vs Heat transfer rate

LOAD (AMPS)	HEAT TRANSFER RATE
0	0
2	270
4	400
6	450
8	400

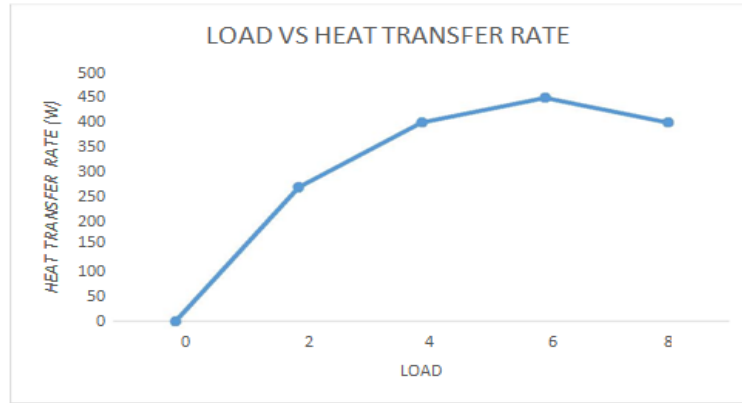

Fig 7.2 Load vs Heat transfer rate

TABLE 7.3 LOAD VS HEAT TRANSFER COEFFICIENT

LOAD (AMPS)	h1 (W/m ² K)	h2 (W/m ² K)	h3 (W/m ² K)	h4 (W/m ² K)	h5 (W/m ² K)
0	0	0	0	0	0
2	19.66	16.58	14.93	13.74	12.43
4	48.53	42.1	37.39	35.47	33.92
6	142.86	135.2	134.35	135.05	130.27
8	476.19	166	317.4	254	272.1

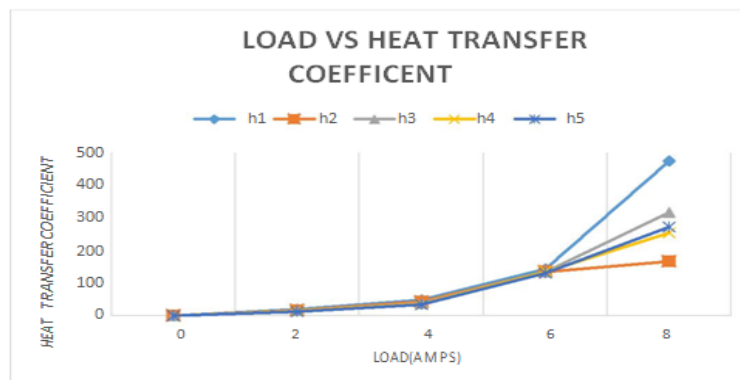

Fig 7.3 Load Vs Heat transfer coefficient

Table 7.4 Temperature at different position with varying load

X(cms)	NO LOAD	20% LOAD	40% LOAD	60% LOAD	80% LOAD
0	1382	1620	1796	1950	2150
1	859	974	1093	1152	1204
10	374	386	393	395	410
25	82	92	86	93	95
30	72	69	74	78	81

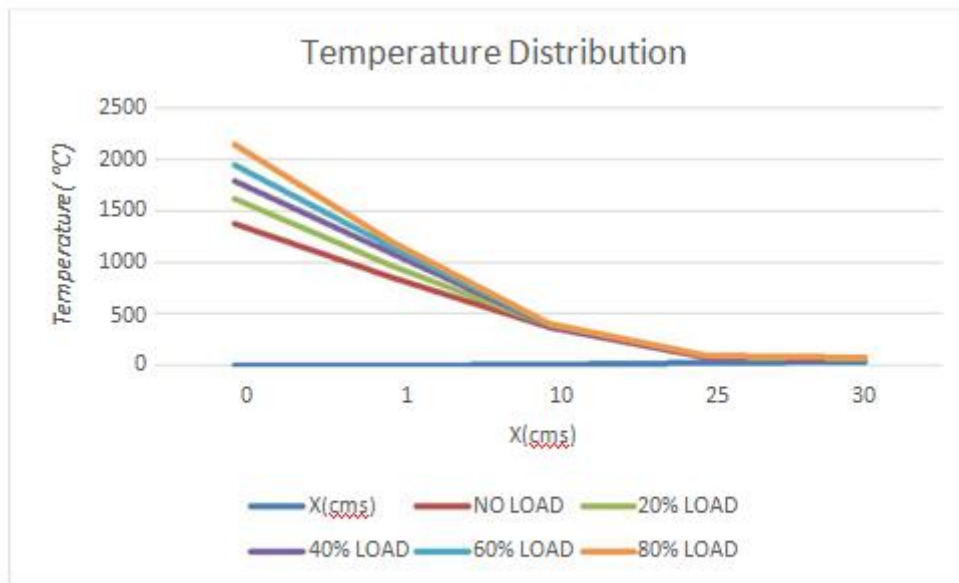

Fig 7.4 Temperature distribution at various positions

These graphs show that heat transfer from the combustion gas to the atmosphere. T1 is the thermocouple which is used to measure the combustion gas temperature. T2 is the thermocouple which is used to measure the cylinder liner temperature. T3 is the thermocouple which is used to measure the cylinder head surface temperature or the fin base temperature. T4 is the thermocouple which is used to measure the temperature in the fin section. T5 is the thermocouple which is used to measure the temperature at the fin tip. During compression and expansion strokes, the correlations for the convection coefficient are mostly used and provide a good estimation of the heat transfers. A bibliographical study shows that the studies having established these formulae never consider the intake stroke precisely. The current constraints for the engine conception bring to conceive evolved aerodynamic strategies during the intake stroke. The question is to know if these very strong and structured aerodynamic structures can modify significantly the characteristics of the convection levels during the intake stroke. It is

now possible to attend, on a single cycle and with a good temporal resolution, to the development mechanisms of the aerodynamic structures.

VIII. CONCLUSION

Combustion is an important parameter for knocking in spark ignition engine s stoichiometric air fuel ratio; proper spark timing and flame propagation are favour for complete combustion.

Heat transfer is an important parameter for thermal efficiency and knocking in air cooled engine, higher thermal conductive material heat transfer more amount of heat from cylinder

From this analysis we can create new small scale engine models, and also helpful for developing low heat rejection engines and hybrid engines.

REFERENCES

1. Elisa Carvajal Trujillo, Francisco J. Jimenez-Espadafor (2011), "Methodology for the estimation of cylinder inner surface temperature in an air-cooled engine" Applied Thermal Engineering, Volume 31, Page 1474-1481.
2. J. Galindo, H. Climent, B. Pla, V.D. Jimenez (2011), "Correlations for Wiebe function parameters for combustion simulation in two-stroke small engines" Applied Thermal Engineering, Volume 31, Page 1190- 1199.
3. M. Costa, U. Sorge, L. Allocca (2011), "Numerical study of the mixture formation process in a four-stroke GDI engine for two-wheel applications", Simulation Modelling Practice and Theory, Volume 19, Page 1212-1226.
4. Mohammadi, M. Yaghoubi , M. Rashidi (2008), "Analysis of local convective heat transfer in a spark ignition engine" International Communications in Heat and Mass Transfer, Volume 35, page 215- 224.
5. Mohammadi, M. Yaghoubi (2010), "Estimation of instantaneous local heat transfer coefficient in spark-ignition engines", International Journal of Thermal Sciences, Volume 49, Page 1309-1317.
6. M.M. Rahman, Mohammed Kamil, Rosli A. Bakar (2011), "Engine performance and optimum injection timing for 4-cylinder direct injection hydrogen fuelled engine", Simulation Modelling Practice and Theory, Volume 19, Page 734-751
7. G.C. Mavropoulos (2011), "Experimental study of the interactions between long and short-term unsteady heat transfer responses on the in-cylinder and exhaust manifold diesel engine surfaces", Applied Energy, Volume 88, Page 867- 881
8. Yuh-Yih Wu, Bo-Chiuan Chen, Feng-Chi Hsieh (2006), "Heat transfer model for small-scale air-cooled Spark-ignition four-stroke engines" International Journal of Heat and Mass Transfer , Volume 49 , Page 3895-3905
9. S. Verhelst, C.G.W. Sheppard (2009), "Multi-zone thermodynamic modelling of spark-ignition engine combustion -- An overview", Energy Conversion and Management, Volume 50, Page 1326-1335.
10. D. Descieux , M. Feidt (2006), "One zone thermodynamic modelsimulation of an ignition compression engine", Applied Thermal Engineering, Volume 50, Page 1457-1466
11. SreckoManasijevic, RadomirRadisa(2011), "Thermal analysis and microscopic characterization of the piston alloy AISi13Cu4Ni2Mg", Intermetallics, Volume 19, Page 486-492
12. Y.D. Huang, N. Hort, K.U. Kainer(2004)" Thermal behavior of fiber reinforced AISi12CuMgNi piston alloys", Composites: Part A, Volume 35, Page 249-263