

Area and Delay Efficient Digital Comparator

Poomaran¹, Ramesh Kumar²

PG Scholar, NPR Engineering College, Dindigul, Tamil Nadu, India¹

Assistant Professor, NPR Engineering College, Dindigul, Tamil Nadu, India²

ABSTRACT: Quantum-dot cellular automata (QCA) tend to be an attractive emerging technology suitable for the development of ultra-dense low-power high-performance digital circuits. Efficient solutions have recently been proposed for several arithmetic circuits, such as adders, multipliers, and comparators. This paper proposes a new design approach oriented to the implementation of binary comparators in QCA. The proposed work uses novel implementation strategies, methodologies and new formulations of basic logic equations to make the comparison function applied to comparator efficient. The new strategy has been exploited in the design of two different comparator architectures and for several operands word lengths. The comparators are proposed here exhibit significantly higher speed and reduced overall area. The existing and proposed comparators are synthesized using Xilinx and performance is evaluated in terms of number of gates and delay.

KEYWORDS: Binary comparators, majority gates, Quantum-dot cellular automata (QCA).

I. INTRODUCTION

Quantum-dot cellular automata (QCA) technology

provides a promising opportunity to overcome the approaching limits of conventional CMOS technology [1]–[6]. For this reason, in recent years the design of logic circuits based on QCA received a great deal of attention, and special efforts have been directed towards arithmetic circuits, such as adders [7]–[14], multipliers [15]–[21] and comparators [22]–[28]. Even though comparators are key elements for a wide range of applications [29][30]. QCA implementations existing in the literature are mainly provided for comparing two single bits. Only few examples of comparators able to process n -bit operands, with $n > 2$, are available [24][26][27]. The comparator described in [22] simply computes the XNOR function to check whether two input bits a and b match each other. The structures proposed in [23]–[28] have higher computational capabilities, and circuits able to recognize all the three possible conditions in which $a = b$, $a > b$ and $a < b$ (full comparators) are described in [23][24] and [27]. The 1-bit implementation is proposed in [23] and then improved in [25], has been exploited in [27] to design a parallel n -bit full comparator. An example of serial structures is provided in [24], whereas the n -bit comparator described in [26] can recognize only the case in which, A and B being the n bit inputs, $A \geq B$.

With respect to other QCA designs, the latter exhibit reduced delays, area occupancy and number of used cells.

This paper focuses on the design of efficient parallel QCA based n -bit full comparators. The novel theorems were applied to achieve innovative QCA based structures of n -bit full comparators that were laid out and are synthesized using Xilinx Tool. The rest of the paper is organized as follows: a brief background of the QCA design approach and existing QCA implementations of binary comparators is given in Section II; the proposed comparator based on new theorems and corollaries are then enunciated and demonstrated in Section III; Simulation results and comparison of performance is done in Section IV; Finally, in Section V, conclusion is presented.

II. BACKGROUND AND RELATED WORKS

The basic element of a nanostructure based on QCA is square cell with four quantum dots and two free electrons. The latter can tunnel through the dots within the cell but owing to Coulombic repulsion, they will always reside in opposite corners [1], thus leading to only two possible stable states, also named polarizations. Locations of the electrons in the cell are associated with the binary states 1 and 0. Adjacent cells interact through electrostatic forces and

International Journal of Innovative Research in Science, Engineering and Technology

An ISO 3297: 2007 Certified Organization

Volume 4, Special Issue 5, April 2015

International Conference On Emerging Trends in Engineering and Technology (ICETET'15)

On 13th & 14th March 2015

Organized by

Pandian Saraswathi Yadav Engineering College, Arasanoor, Sivagangai, Tamilnadu, India

tend to align their polarizations. However, QCA cells do not have intrinsic data flow directionality. Therefore, to achieve controllable data directions, the cells within a QCA design are partitioned into the so-called clock zones that are progressively associated with four clock signals, each phase shifted by 90°. This clock scheme, named the zone clocking scheme, makes the QCA designs intrinsically pipelined, since each clock zone behaves like a D-latch [20]. QCA cells are used for both logic structures and interconnections that can exploit either the coplanar cross or the bridge technique [1][2][6][31][32]. The fundamental logic gates inherently available within the QCA technology are the inverter and the majority gate (MG). Given three inputs a , b and c , the MG performs the logic function reported in [1] provided that all input cells are associated with the same clock signal clk_x (with x ranging from 0 to 3), whereas the remaining cells of the MG are associated with the clock signal clk_{x+1}

$$M(a, b, c) = a \cdot b + a \cdot c + b \cdot c \quad (1)$$

There are several QCA designs of comparators in the literature [22]–[28]. A 1-bit binary comparator receives two bits a and b as inputs and establishes whether they are equal, less than or greater than each other. These possible states are represented through three output signals, here named $A_{eq}B$, $A_{big}B$, $B_{big}A$, that are asserted, respectively, when $a = b$, $a > b$, and $a < b$. Full comparators are those that can separately identify all the above cases, whereas non-full comparators recognize just one or two of them. As an example, the comparator designed in [22] and depicted in Fig. 1(a) can verify only whether $a = b$. Conversely, the circuits shown in **Fig. 1(b) and (c)**, proposed in [23] and [24], are full comparators. The latter also exploits two 1-bit registers D to process n -bit operands serially from the least significant bit to the most significant one. With the main objective of reducing the number of wire crossings, which is still a big challenge of QCA designs [33]–[35] in [25] the universal logic gate (ULG) $f(y_1, y_2, y_3) = M(M(y_1, y_2, 0), M(y_1, y_3, 1), 1)$ was proposed and then used to implement the comparator illustrated in Fig. 1(d). It is worth noting that, two n -bit numbers $A(n-1:0) = a_{n-1} \dots a_0$ and $B(n-1:0) = b_{n-1} \dots b_0$ can be processed by cascading n instances of the 1-bit comparator. Each instance receives as inputs the i th bits a_i and b_i (with $i = n - 1, \dots, 0$) of the operands and the signals $A_{big}B(i-1:0)$ and $B_{big}A(i-1:0)$. The former is asserted when the subword $A(i-1:0) = a_{i-1} \dots a_0$ represents a binary number greater than $B(i-1:0) = b_{i-1} \dots b_0$. In a similar way, $B_{big}A(i-1:0)$ is set to 1 when $A(i-1:0) < B(i-1:0)$. The outputs $A_{big}B(i:0)$ and $B_{big}A(i:0)$ directly feed the next stage. It can be seen that this circuit does not identify the case in which $A = B$, therefore it cannot be classified as a full-comparator. With the main objective of reducing the number of wire crossings, which is still a big challenge of QCA designs [33]–[35], in [25] the universal logic gate (ULG) $f(y_1, y_2, y_3) = M(M(y_1, y_2, 0), M(y_1, y_3, 1), 1)$ was proposed and then used to implement the comparator illustrated in Fig. 1(d). It is worth noting that, two n -bit numbers $A(n-1:0) = a_{n-1} \dots a_0$ and $B(n-1:0) = b_{n-1} \dots b_0$ can be processed by cascading n instances of the 1-bit comparator. Each instance receives as inputs the i th bits a_i and b_i (with $i = n - 1, 0$) of the operands and the signals $A_{big}B(i-1:0)$ and $B_{big}A(i-1:0)$. The former is asserted when the subword $A(i-1:0) = a_{i-1} \dots a_0$ represents a binary number greater than $B(i-1:0) = b_{i-1} \dots b_0$. In a similar way, $B_{big}A(i-1:0)$ is set to 1 when $A(i-1:0) < B(i-1:0)$. The outputs $A_{big}B(i:0)$ and $B_{big}A(i:0)$ directly feed the next stage. It can be seen that this circuit does not identify the case in which $A = B$, therefore it cannot be classified as a full-comparator.

The design described in [26] exploits a tree-based (TB) architecture and exhibits a delay that in theory logarithmically increases with n . The 2-bit version of such designed comparator is illustrated in Fig. 1(e). Also the full comparator proposed in [27] exploits a TB architecture to achieve high speed. As shown in Fig. 1(f), where 4-bit operands are assumed, one instance of the 1-bit comparator presented in [23] is used for each bit position. The intermediate results obtained in this way are then further processed through a proper number of cascaded 2-input OR and AND gates implemented by means of MGs having one input permanently set to 1 and 0, respectively.

Analyzing existing QCA implementations of binary comparators it can be observed that they were designed directly mapping the basic Boolean functions consolidated for the CMOS logic designs to MGs and inverters, or ULGs. Unfortunately, in this way the computational capability offered by each MG could be underutilized [13][36][37]. As a consequence, both the complexity and the overall delay of the resulting QCA designs could be increased in vain.

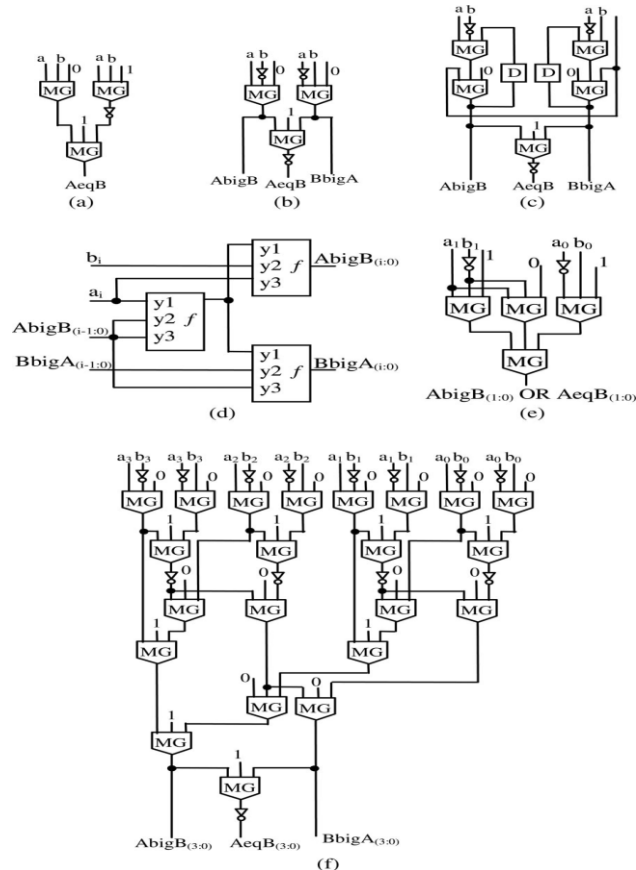

Fig. 1. QCA-based comparators presented in: (a) [22]; (b) [23]; (c) [24];(d) [25]; (e) [26]; (f) [27].

III. THEOREMS AND COROLLARIES OF *n*-BIT FULL COMPARATORS

In this section, four original theorems and two corollaries are enunciated that can significantly increase the speed performances of QCA-based designs of full comparators and can significantly reduce the number of used MGs and inverters with respect to existing comparators, thus reducing also the number of used cells and the overall active area.

The novel formulations can be exploited in the design of *n*-bit full comparators splitting the operands $A(n-1:0) = a_{n-1} \dots a_0$ and $B(n-1:0) = b_{n-1} \dots b_0$ into a proper number of 2-bit and 3-bit subwords that can be compared applying Theorems 1 and 2. The intermediate results obtained in this way can be then further processed by applying Theorems 3 and 4 together with Corollaries 1 and 2.

Theorem 1:

If $A(k-1:k-2) = a_{k-1}a_{k-2}$ and $B(k-1:k-2) = b_{k-1}b_{k-2}$, with $k = 2, 4, \dots, n-2, n$, are two 2-bit subwords of the *n*-bit numbers $A(n-1:0)$ and $B(n-1:0)$, respectively, then $AbigB(k-1:k-2)$ as defined in (2) is equal to 1 if and only if $A(k-1:k-2) > B(k-1:k-2)$; $BbigA(k-1:k-2)$ as defined in (3) is equal to 0 if and only if $A(k-1:k-2) < B(k-1:k-2)$.

$$AbigB_{(k-1:k-2)} = M(a_{k-1}, \overline{b_{k-1}}, a_{k-2}) \cdot M(a_{k-1}, \overline{b_{k-1}}, \overline{b_{k-2}}) \quad (2)$$

$$\overline{BbigA}_{(k-1:k-2)} = M(a_{k-1}, \overline{b_{k-1}}, a_{k-2}) + M(a_{k-1}, \overline{b_{k-1}}, \overline{b_{k-2}}) \quad (3)$$

International Journal of Innovative Research in Science, Engineering and Technology

An ISO 3297: 2007 Certified Organization

Volume 4, Special Issue 5, April 2015

International Conference On Emerging Trends in Engineering and Technology (ICETET'15)

On 13th & 14th March 2015

Organized by

Pandian Saraswathi Yadav Engineering College, Arasanoor, Sivagangai, Tamilnadu, India

Theorem 2:

If $A(k-1:k-3) = a_{k-1}a_{k-2}a_{k-3}$ and $B(k-1:k-3) = b_{k-1}b_{k-2}b_{k-3}$, with $k = 3, 6, \dots, n-3, n$, are 3-bit subwords of the n -bit numbers $A(n-1:0)$ and $B(n-1:0)$, respectively, then $A_{\text{big}}B(k-1:k-3)$ as defined in (4) is equal to 1 if and only if $A(k-1:k-3) > B(k-1:k-3)$; $B_{\text{big}}A(k-1:k-3)$ as given in (5) is equal to 0 if and only if $A(k-1:k-3) < B(k-1:k-3)$.

$$A_{\text{big}}B(k-1:k-3) = M(M(a_{k-1}, \overline{b_{k-1}}, a_{k-2}), M(a_{k-1}, \overline{b_{k-1}}, \overline{b_{k-2}}), a_{k-3} \cdot \overline{b_{k-3}}) \quad (4)$$

$$\overline{B_{\text{big}}A(k-1:k-3)} = M(M(a_{k-1}, \overline{b_{k-1}}, a_{k-2}), M(a_{k-1}, \overline{b_{k-1}}, \overline{b_{k-2}}), a_{k-3} + \overline{b_{k-3}}). \quad (5)$$

Theorem 3:

Given two n -bit numbers $A(n-1:0)$ and $B(n-1:0)$, (6) gives $A_{\text{big}}B(n-1:0) = 1$ if and only if $A(n-1:0) > B(n-1:0)$, whereas (7) gives $B_{\text{big}}A(n-1:0) = 0$ if and only if $A(n-1:0) < B(n-1:0)$.

$$A_{\text{big}}B(n-1:0) = M(M(a_{n-1}, \overline{b_{n-1}}, a_{n-2}), M(a_{n-1}, \overline{b_{n-1}}, \overline{b_{n-2}}), A_{\text{big}}B(n-3:0)) \quad (6)$$

$$\overline{B_{\text{big}}A(n-1:0)} = M(M(a_{n-1}, \overline{b_{n-1}}, a_{n-2}), M(a_{n-1}, \overline{b_{n-1}}, \overline{b_{n-2}}), \overline{B_{\text{big}}A(n-3:0)}) \quad (7)$$

Theorem 4:

If $A(n-1:0)$ and $B(n-1:0)$ are two n -bit numbers, then $A_{\text{big}}B(n-1:n-3)$ and $B_{\text{big}}A(n-1:n-3)$ being computed by (4) and (5), respectively, then $A_{\text{big}}B(n-1:0)$ as defined in (8) is equal to 1 if and only if $A(n-1:0) > B(n-1:0)$, whereas $B_{\text{big}}A(n-1:0)$ as defined in (9) is equal to 0 if and only if $A(n-1:0) < B(n-1:0)$.

$$A_{\text{big}}B(n-1:0) = M(A_{\text{big}}B(n-1:n-3), \overline{B_{\text{big}}A(n-1:n-3)}, A_{\text{big}}B(n-4:0)) \quad (8)$$

$$\overline{B_{\text{big}}A(n-1:0)} = M(A_{\text{big}}B(n-1:n-3), \overline{B_{\text{big}}A(n-1:n-3)}, \overline{B_{\text{big}}A(n-4:0)}) \quad (9)$$

Corollary 1:

Let's consider two n -bit numbers $A(n-1:0)$ and $B(n-1:0)$, and let's suppose that they are split into the subwords $A(n-1:h), A(h-1:0), B(n-1:h)$ and $B(h-1:0)$. If $A_{\text{big}}B(n-1:h), A_{\text{big}}B(h-1:0), B_{\text{big}}A(n-1:h)$ and $B_{\text{big}}A(h-1:0)$ are computed by applying Theorems 3 and 4, then $A_{\text{big}}B(n-1:0)$ as defined in (10) is equal to 1 if and only if $A(n-1:0) > B(n-1:0)$, whereas $B_{\text{big}}A(n-1:0)$ as defined in (11) is equal to 0 if and only if $A(n-1:0) < B(n-1:0)$.

$$A_{\text{big}}B(n-1:0) = M(A_{\text{big}}B(n-1:h), \overline{B_{\text{big}}A(n-1:h)}, A_{\text{big}}B(h-1:0)) \quad (10)$$

$$\overline{B_{\text{big}}A(n-1:0)} = M(A_{\text{big}}B(n-1:h), \overline{B_{\text{big}}A(n-1:h)}, \overline{B_{\text{big}}A(h-1:0)}) \quad (11)$$

Corollary 2:

Given two n -bit numbers $A(n-1:0)$ and $B(n-1:0)$, if $A_{\text{big}}B(n-1:0)$ and $B_{\text{big}}A(n-1:0)$ are computed by applying Theorems 1, 2, 3, and 4 and/or Corollary 1, then $A_{\text{eq}}B(n-1:0)$ defined in (12) is equal to 1 if and only if $A(n-1:0) = B(n-1:0)$.

$$A_{\text{eq}}B(n-1:0) = M(\overline{A_{\text{big}}B(n-1:0)}, \overline{B_{\text{big}}A(n-1:0)}, 0) \quad (12)$$

In order to exploit the novel approach, the operands $A(n-1:0)$ and $B(n-1:0)$ are split into a proper number of 2- and 3-bit subwords that are compared applying Theorems 1 and 2. The results obtained comparing 2- and 3-bit subwords are then combined by applying Theorems 3 and 4 together with Corollaries 1 and 2.

IV. PROPOSED BINARY COMPARATOR

The circuits illustrated in Fig. 2 were designed to implement in QCA the novel equations demonstrated in the previous Section. The generic module T_i , with i ranging between 1 and 4, implements the equations enunciated in the i th theorem, whereas C1 and C2 compute the signals $AbigB(k-1:0)$, $BbigA(k-1:0)$, and $AeqB(k-1:0)$ as shown above in Corollaries 1 and 2, respectively. As examples of application, the above QCA modules have been used to design two different structures of full comparators named cascade-based and TB architectures. However, many other structures can be designed by combining the basic modules in different manners.

A) Novel QCA Comparators

The first proposed comparator exploits a cascade-based (CB) architecture. To explain better how the overall computation is performed, the schematic diagram illustrated in Fig. 3 is provided. It shows a possible implementation of a 32-bit comparator based on the proposed theory.

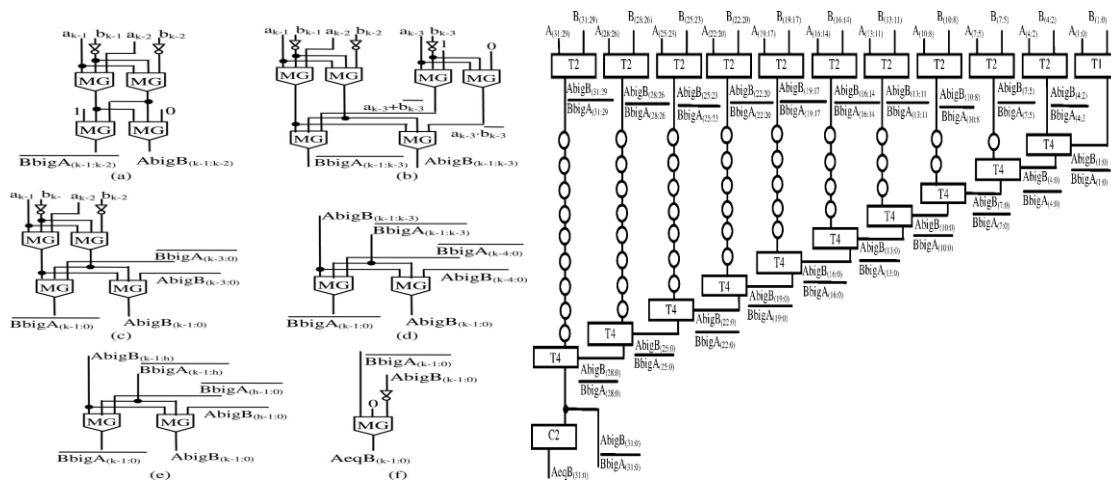

Fig. 2. QCA modules: (a) T1; (b) T2; (c) T3; (d) T4; (e) C1; and (f) C2. Fig. 3. Novel 32-bit CB full comparator.

Circles visible in Fig. 3 indicate the additional clock phases that have to be inserted on wires to guarantee the correct synchronization of the overall design. The CB full comparator was designed for operands wordlengths ranging from 2 to 32 and using, for $n > 2$, the split criterion summarized in Table I. Obviously, alternative splits could be used.

TABLE I. SPLITTING CRITERION ADOPTED IN THE CB COMPARATORS

| n | Splitting of the operands | |
|-----|--|-------------------------------|
| 4 | $A_{(3:2)}A_{(1:0)}$ | $B_{(3:2)}B_{(1:0)}$ |
| 8 | $A_{(7:5)}A_{(4:2)}A_{(1:0)}$ | $B_{(7:5)}B_{(4:2)}B_{(1:0)}$ |
| 16 | $A_{(15:14)}A_{(13:11)}A_{(10:8)}A_{(7:5)}A_{(4:2)}A_{(1:0)}$ $B_{(15:14)}B_{(13:11)}B_{(10:8)}B_{(7:5)}B_{(4:2)}B_{(1:0)}$ | |
| 32 | $A_{(31:29)}A_{(28:26)}A_{(25:23)}A_{(22:20)}A_{(19:17)}A_{(16:14)}A_{(13:11)}A_{(10:8)}A_{(7:5)}A_{(4:2)}A_{(1:0)}$ $B_{(31:29)}B_{(28:26)}B_{(25:23)}B_{(22:20)}B_{(19:17)}B_{(16:14)}B_{(13:11)}B_{(10:8)}B_{(7:5)}B_{(4:2)}B_{(1:0)}$ | |

As it is well known, the number of cascaded MGs within the worst computational path of a QCA design directly affects the delay achieved. In fact, each MG introduces one clock phase in the overall delay. From Fig. 2, it can be seen

that the modules T1 and T2 contribute to the computational path with one inverter and two MGs. Each instance of T4 introduces one more MG, whereas C2 is responsible for one MG and one inverter. As a consequence, the critical computational path of the novel n -bit CB full comparator consists of $n/3+ 3$ MGs and 2 inverters. As an example, the 32-bit implementation depicted in Fig. 3 has the worst-case path made up of 13 MGs and 2 inverters. The number of MGs within the computational path of the above described comparator linearly increases with n . An alternative solution presented here adopts a TB architecture to achieve shorter computational paths. When this approach is exploited, several implementations of an n -bit full comparator can be designed differently combining the novel theorems and corollaries, as well as their QCA implementations depicted in Fig. 2.

The TB comparators implement the comparison function recursively. The operands A and B are preliminarily partitioned as $A = AMSBALS$ and $B = BMSBLSB$. The portions $AMSB$ and $BMSB$ are compared independently of the portions $ALSB$ and $BLSB$. The depth of the recursion directly impacts the whole architecture. Examples of TB structures designed for 16- and 32-bit comparators are illustrated in Fig. 4. In Fig. 4(b) and (d), the recursion with its minimum depth is adopted. The portions $AMSB$ and $BMSB$, as well as the portions $ALSB$ and $BLSB$, are separately compared through two independent CB architectures. The overall result is finally built with the modules C1 and C2. Fig. 4(a) and (c) shows comparators designed adopting deeper recursions. In the following of the paper, the 16- and 32-bit TB implementations illustrated in Fig. 4(b) and (d) are deeply analyzed. Referring to the QCA modules depicted in Fig. 2, it can be easily verified that the former uses 35 MGs and 17 inverters and its critical computational path consists of 7 MGs and 2 inverters, whereas the latter utilizes 83 MGs and 33 inverters and it has a worst-case path composed by 9 MGs and 2 inverters.

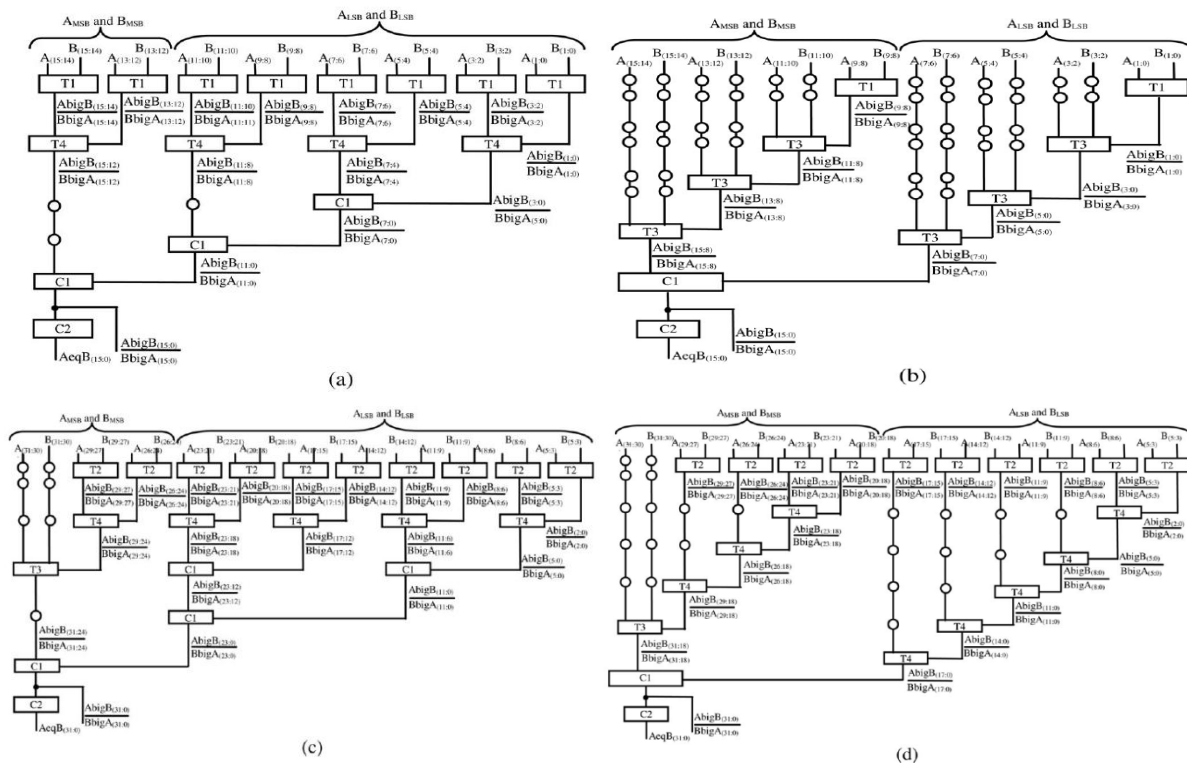

Fig. 4. Examples of novel TB comparators with: (a) and (b) 16-bit operands; (c) and (d) 32-bit inputs.

International Journal of Innovative Research in Science, Engineering and Technology

An ISO 3297: 2007 Certified Organization

Volume 4, Special Issue 5, April 2015

International Conference On Emerging Trends in Engineering and Technology (ICETET'15)

On 13th & 14th March 2015

Organized by

Pandian Saraswathi Yadav Engineering College, Arasanoor, Sivagangai, Tamilnadu, India

V. RESULTS AND DISCUSSION

The performance of the tree based and cascade based architectures are compared in terms of number of gates. The cascade based approach uses large number of MGs compared to Tree based approach.

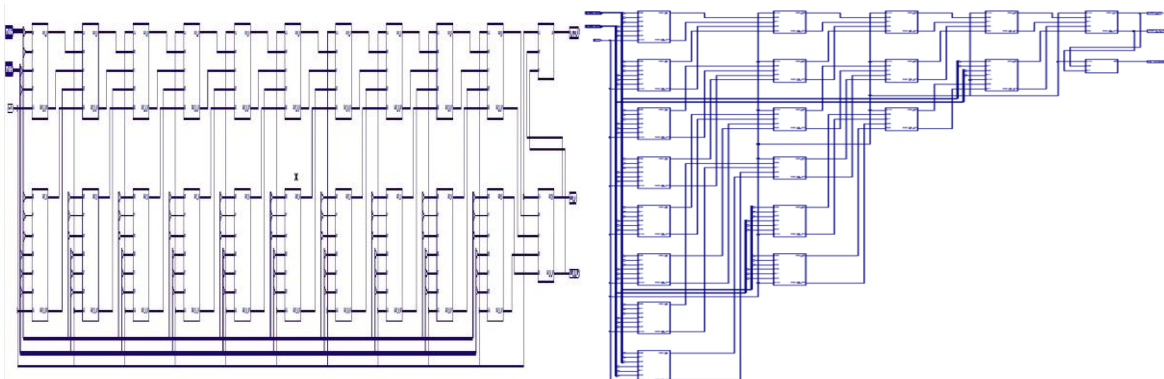

Fig. 5. Equivalent Cascade based comparator RTL diagram Fig. 6. Equivalent Tree based comparator RTL diagram

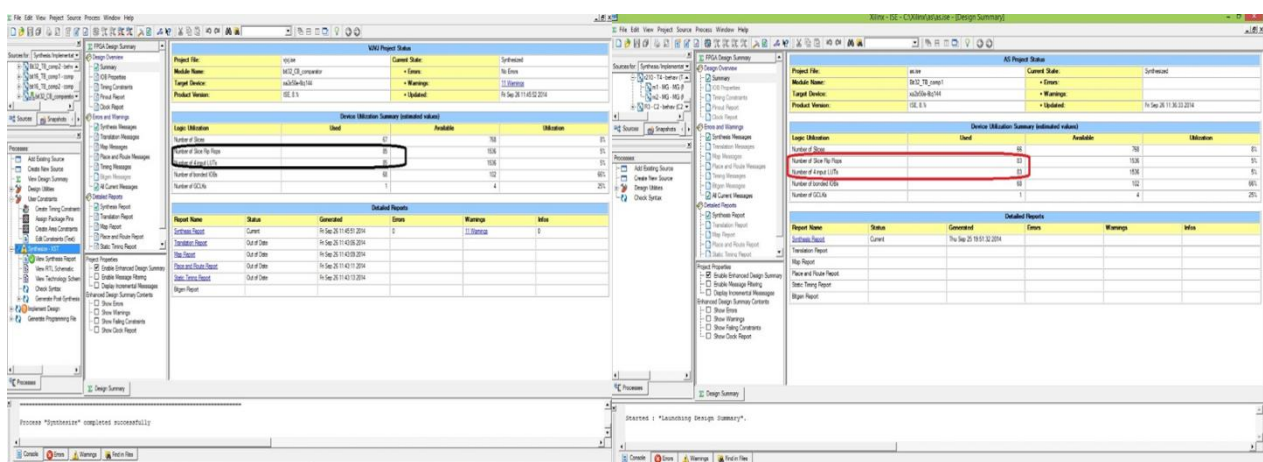

Fig. 7. Synthesis result for Cascade based comparator Fig. 8. Synthesis result for Tree based comparator

TABLE II RESULTS

| Design Architecture | No of gates used |
|---------------------|------------------|
| CB | 85 |
| TB | 83 |

IV. CONCLUSION

A new methodology useful to design binary comparators in QCA has been presented. The novel comparators split the received n -bit inputs into a proper number of 2- and 3-bit subwords that are processed in parallel through 2- and 3-bit comparators designed by applying theorems demonstrated here. The proposed TB architecture is efficient compared to CB architecture.

International Journal of Innovative Research in Science, Engineering and Technology

An ISO 3297: 2007 Certified Organization

Volume 4, Special Issue 5, April 2015

International Conference On Emerging Trends in Engineering and Technology (ICETET'15)

On 13th & 14th March 2015

Organized by

Pandian Saraswathi Yadav Engineering College, Arasanoor, Sivagangai, Tamilnadu, India

REFERENCES

- [1] C. S. Lent, P. D. Tougaw, W. Porod, and G. H. Bernstein, "Quantumcellular automata," *Nanotechnology*, vol. 4, no. 1, pp. 49–57, 1993.
- [2] M. T. Niemer and P. M. Kogge, "Problems in designing with QCAs: Layout= timing," *Int. J. Circuit Theory Appl.*, vol. 29, pp. 49–62, 2001.
- [3] G. H. Bernstein, A. Imre, V. Metlushko, A. Orlov, L. Zhou, L. Ji, G. Csaba, and W. Porod, "Magnetic QCA systems," *Microelectron. J.*, vol. 36, pp. 619–624, 2005.
- [4] J. Huang and F. Lombardi, *Design and Test of Digital Circuits by Quantum-Dot Cellular Automata*. Norwood, MA, USA: Artech House, 2007.
- [5] W. Liu, L. Lu, M. O'Neill, and E. E. Swartzlander Jr., "Design rules for quantum-dot cellular automata," in *Proc. IEEE Int. Symp. Circuits Syst. (ISCAS)*, Rio De Janeiro, Brazil, May 2011, pp. 2361–2364.
- [6] K. Kim, K. Wu, and R. Karri, "Towards designing robust QCA architectures in the presence of sneak noise paths," in *Proc. IEEE Design, Automation Test Eur. Conf. Exhib. (DATE)*, Munich, Germany, Mar. 2005, pp. 1214–1219.
- [7] K. Navi, M. H. Moaiyeri, R. F. Mirzaee, O. Hashemipour, and B. M. Nezhad, "Two new low-power full adders based on majority-not gates," *Microelectron. J.*, vol. 40, pp. 126–130, 2009.
- [8] H. Cho and E. E. Swartzlander Jr., "Adder design and analyses for quantum-dot cellular automata," *IEEE Trans. Nanotechnol.*, vol. 6, no. 3, pp. 374–383, May 2007.
- [9] H. Cho and E. E. Swartzlander Jr., "Adder and multiplier design in quantum-dot cellular automata," *IEEE Trans. Comput.*, vol. 58, no. 6, pp. 721–727, Apr. 2009.
- [10] V. Pudi and K. Sridharan, "Efficient design of a hybrid adder in quantum dot cellular automata," *IEEE Trans. VLSI Syst.*, vol. 19, no. 9, pp. 1535–1548, Jul. 2011.
- [11] M. Gladshstein, "Quantum-dot cellular automata serial decimal adder," *IEEE Trans. Nanotechnol.*, vol. 10, no. 6, pp. 1377–1382, Nov. 2011.
- [12] V. Pudi and K. Sridharan, "Low complexity design of ripple carry and Brent-Kung adders in QCA," *IEEE Trans. Nanotechnol.*, vol. 11, no. 1, pp. 105–119, Jan. 2012.
- [13] S. Perri and P. Corsonello, "New methodology for the design of efficient binary circuits addition in QCA," *IEEE Trans. Nanotechnol.*, vol. 11, no. 6, pp. 1192–1200, Nov. 2012.
- [14] V. Pudi and K. Sridharan, "New decomposition theorems on majority logic for low-delay adder designs in quantum dot cellular automata," *IEEE Trans. Circuits Syst. II: Exp. Briefs*, vol. 59, no. 10, pp. 678–682, Oct. 2012.
- [15] H. Cho and E. E. Swartzlander Jr., "Serial parallel multiplier design in quantum-dot cellular automata," in *Proc. IEEE Symp. Comput. Arithmetic*, 2007, pp. 7–15.
- [16] S. W. Kim and E. E. Swartzlander Jr., "Parallel multipliers for quantum dot cellular automata," in *Proc. IEEE Nanotechnol. Mater. Devices Conf.*, 2009, pp. 68–72.
- [17] S. W. Kim and E. E. Swartzlander Jr., "Multipliers with coplanar crossings for quantum-dot cellular automata," in *Proc. IEEE Int. Conf. Nanotechnol.*, 2010, pp. 953–957.
- [18] W. Liu, L. Lu, M. O'Neill, and E. E. Swartzlander Jr., "Montgomery modular multiplier design in quantum-dot cellular automata using cut-set retiming," in *Proc. IEEE Int. Conf. Nanotechnol.*, 2010, pp. 205–210.
- [19] L. Lu, W. Liu, M. O'Neill, and E. E. Swartzlander Jr., "QCA systolic matrix multiplier," in *Proc. IEEE Annu. Symp. VLSI*, 2010, pp. 149–154.
- [20] J. D. Wood and D. Tougaw, "Matrix multiplication using quantum-dot cellular automata to implement conventional microelectronics," *IEEE Trans. Nanotechnol.*, vol. 10, no. 5, pp. 1036–1042, Sep. 2011.
- [21] L. Lu, W. Liu, M. O'Neill, and E. E. Swartzlander Jr., "QCA systolic array design," *IEEE Trans. Comput.*, vol. 62, no. 3, pp. 548–560, Mar. 2013.
- [22] J. R. Janulis, P. D. Tougaw, S. C. Henderson, and E. W. Johnson, "Serial bit-stream analysis using quantum-dot cellular automata," *IEEE Trans. Nanotechnol.*, vol. 3, no. 1, pp. 158–164, Mar. 2004.
- [23] K. Qiu and Y. Xia, "Quantum-dots cellular automata comparator," in *Proc. Int. Conf. ASIC*, 2007, pp. 1297–1300.
- [24] B. Lamprecht, L. Stepanic, I. Vizec, and B. Zankar, "Quantum-dot cellular automata serial comparator," in *Proc. EUROMICRO Conf. Digital Syst. Design Architectures, Methods Tools*, 2008, pp. 447–452.
- [25] Y. Xia and K. Qiu, "Design and application of universal logic gate based on quantum-dot cellular automata," in *Proc. IEEE Int. Conf. Commun. Technol.*, 2008, pp. 335–338.
- [26] M. D. Wagh, Y. Sun, and V. Annampedu, "Implementation of comparison function using quantum-dot cellular automata," in *Proc. Nanotechnol. Conf. Trade Show*, 2008, pp. 76–79.
- [27] Y. Xia and K. Qiu, "Comparator design based on quantum-dot cellular automata," *J. Electron. Inf. Technol.*, vol. 31, no. 6, pp. 1517–1520, 2009.
- [28] S. Ying, T. Pei, and L. Xiao, "Efficient design of QCA optimal universal logic gate ULG.2 and its application," in *Proc. Int. Conf. Comput. Appl. Syst. Modeling (ICCASM)*, 2010, pp. 392–396.
- [29] S. Perri and P. Corsonello, "Fast low-cost implementation of single-clock cycle binary comparator," *IEEE Trans. Circuits Syst. II: Exp. Briefs*, vol. 55, no. 12, pp. 1239–1243, Dec. 2008.
- [30] P. Chuang, D. Li, and M. Sachdev, "A low-power high-performance single cycle tree-based 64-bit binary comparator," *IEEE Trans. Circuits Syst. II: Exp. Briefs*, vol. 59, no. 2, pp. 108–112, Feb. 2012.