

Smart Lighting System using Raspberry Pi

Ankit Maslekar ¹, Aparna K ², Mamatha K ³, Shivakumara T ⁴P.G. Student, Department of Master of Computer Applications, BMS Institute of Technology & Management,
Bengaluru, Karnataka, India^{1,3}Associate Professor, Department of Master of Computer Applications, BMS Institute of Technology & Management,
Bengaluru, Karnataka, India²Assistant Professor, Department of Master of Computer Applications, BMS Institute of Technology & Management,
Bengaluru, Karnataka, India⁴

ABSTRACT: Energy is major input sector for economic development of any country. In this paper, it is proposed to develop a Smart Energy Conservation System that will help various organizations to play an effective role in saving electrical energy. The major area which consumes maximum amount of electricity is observed to be the educational institutions. They are used nearly 70% of the time by students and faculties. A simple action of switching OFF the electric consumables when not in use will save lot of energy. In order to conserve energy, automated lighting system using Raspberry Pi that monitors the electrical lighting and the running of the fans is proposed. The experimental results show that we can reduce our bill to the extent of 50% if the electrical appliances are switched OFF promptly when not in use. The proposed method has shown promising results.

KEYWORDS: Raspberry Pi, Electrical Consumables, Energy Conservation, Automated Lighting, Smart System.

I. INTRODUCTION

To deliver a sustained economic growth rate of 8% to 9% through 2031-32 and to meet life time energy needs of all citizens, India needs to increase its primary energy supply by 3 to 4 times and electricity generation capacity about 6 times. As a result energy service demand growth rates will keep on increasing because of accelerated industrialization, urbanization, and an emerging consumer society. The cost of generating electricity will only go up to keep up with the costs of inflation. In such a scenario, it is very clear that consumers will be paying more prices per unit of electricity consumed, in the years to come.

The simplest technique to save power and consequently the costs is when we switch off the lights and fans as soon as we leave the room. However, this is not a second nature to many of us. The idea is to automate, by creating a device that monitors "changes" in the environment and respond to the situation. By switching off lights and fans in a timely manner, we stand to save costs on electricity bill by at least 30% to 40% even by conservative estimates. The proposed method is implemented using Raspberry Pi [1].



Fig.1: Raspberry Pi

International Journal of Innovative Research in Science, Engineering and Technology

(An ISO 3297: 2007 Certified Organization)

Vol. 4, Issue 7, July 2015

Fig.1 shows the image of a Raspberry Pi. A Raspberry pi is a mini computer that can be plugged with monitor or TV, a keyboard and a mouse [2]. This small device is used by people of all ages to learn and explore computing. Pi can be used to learn Python and Scratch programming. It is capable of doing everything from browsing the internet, playing video and games. The Raspberry Pi has the ability to interact with the real time applications, and is used in different projects, like weather stations, gaming, etc.

The rest of the paper is organized as follows. Section 2 presents the related work done previously in this area. A brief explanation of the proposed method to conserve energy is explained in Section 3. Section 4 discusses the results and analysis. The conclusion is given in Section 5.

II. RELATED WORK

An extensive literature survey has been carried out on different techniques that have been implemented for the lighting system till date.

In [3], the authors describe about automated lighting system with visitor counters. This System needs no manual operation for switching ON / OFF when a person enters or exits from a room. The PIR Sensors with the IR transmitter and receiver are placed at the entrance of the room doors in such a way that the sensor senses a person entering / exiting the room. This can also be done by using a laser. A Microcontroller is a circuit which helps in controlling the lights and fans in a room and keeps track of number of persons / visitors entered or exit from the room. When a person enters into the room then the counter is incremented by one and the lights in the room will be switched ON and when a person leaves the room then the counter is decremented by one. The lights will only be switched OFF until all the persons in the room go out and the room is unoccupied. A display also shows the total number of persons inside the room. But the limitation is that the room doors should not be wide enough as two or more people should not be allowed to enter at the same time.

Sensor Technology [4] is also used for the same objective of conserving energy. For instance, vacancy Sensor allows direct replacement of standard wall switches. Using passive infrared technology (PIR), these sensors combine occupancy detection and voltage switching in a single package. These units automatically turn off lights after a room or an area is vacant for 5 - 10 minutes. The ceiling mount sensors also use passive infrared technology which detects vacancy and turn OFF lights automatically. These sensors are mounted to the ceiling. They have a 180 degree and a 360 degree field of view and can cover up to 1000 square feet of area. But sensor technology also comes with drawbacks. For instance, sensors are more expensive and are likely to break. Moreover, sensors can sense objects / people to a limited range i.e. one sensor might not cover a full room and also it requires lot of additional wiring in case of wired sensors.

In [5], the authors depict a new system of energy saving and control of street lights. This application is built on handling the streetlights more economically and can be operated without any difficulty. Instead of using the usual ON / OFF system, a default light intensity level of 50% is maintained for the lamps by using a digitally controlled power regulator circuit. Traffic is sensed at each pole and a signal is sent to the master control station, which in turn sends command signal to the local pole circuit and the light intensity level is raised to 100% only in the section of the road where traffic is sensed. Thus, a considerable amount of energy is saved, without compromising the lighting requirement and can be maintained with ease. The system is based on the Zigbee networking technology. This system again uses a sensor which is placed near each streetlight. The hardware of the sensor allows it to detect the traffic intensity level and thereby direct the information to the Zigbee end device which is again unique for every lamp pole.

The authors in [6] describe about smart street lighting system based on Programmable Logic Controller (PLC) and input sensing devices. In this paper, an approach for controlling Street Lighting system using millennium 3 PLC is proposed. The proposed controller gives fast, reliable, and power efficient street lamp switching based on seasonal variations. The simulated results are also verified experimentally by using a Light Dependent Resistor (LDR) which senses the light. LDR is used as the replacement for the seasonal variation. This paper confirms that the proposed PLC based street lighting control system has great potential to revolutionize street lighting which in turn

International Journal of Innovative Research in Science, Engineering and Technology

(An ISO 3297: 2007 Certified Organization)

Vol. 4, Issue 7, July 2015

saves large amount of power. But PLC's are used for automation of industrial electro-mechanical processes which does not help in our proposed system

III. PROPOSED WORK

Automated lighting system using Raspberry Pi is a flexible system which reduces electricity bills and carbon emissions. The conserved energy can be generated in the electrical grid and this energy can be used by another individual for different purpose. The system can undergo slight modifications in the hardware and software for the addition of a new module. This system can be used in residential, institutional, commercial and other industries to conserve energy and to reduce the cost of consumables on yearly bases.

The proposed system needs no manual operation for switching OFF lights and fans when a person exits from a room. A Micro SD card is inserted into the slot on the board which acts as the hard drive for the Raspberry Pi. It is powered by USB and the video output. This gives us all of the basic abilities of a normal computer. It also has an extremely low power consumption of about 2 watts (approximately equivalent to a mobile charger). The Raspbian operating system is a lightweight version of Linux that is optimized for this low powered device. With the help of Raspberry Pi we can program the circuit board as per our requirements in Python language [7]. By using a web camera we can capture the images of a room and then compare these images with the human patterns that are stored in the OpenCV (Open source Computer Vision) software [8]. If it fails to match then power supply is disabled. There is no need for any sensors to be installed for this proposed system.

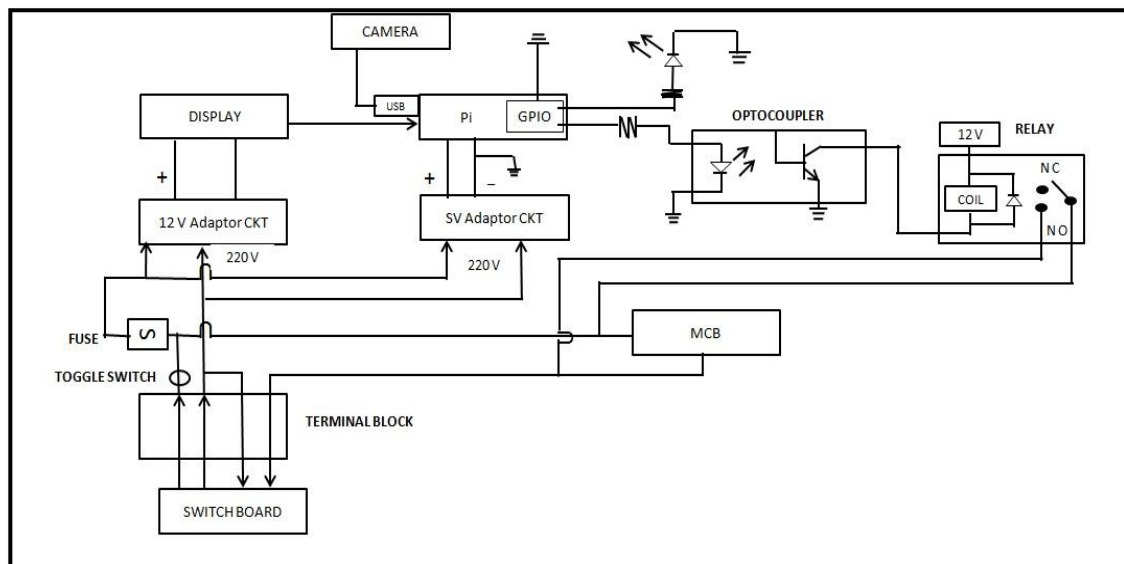

Fig.2: Circuit Diagram

Fig.2 is the circuit diagram for the circuit board with different components and their connections with the switch board. The entire circuit is powered by 220V from the main power line. It is further reduced to 12V and 5V using an adaptor circuit which powers the display and raspberry pi respectively. A fuse is connected between the main power line and the adaptor circuit to secure the circuit in case of a short circuit / overload. The 5V adaptor circuit provides regulated 5V's to the raspberry pi. Raspberry Pi is a multi layer arm processor based CPU. A USB camera is connected to one of the USB ports and a video cable is connected from the raspberry pi to the display. An LED to indicate the status of the relay is connected to GPIO (General Purpose Input Output) pin 18. The GPIO pin 17 is connected to an Optocoupler [9] which in turn controls the switching of a relay. The relay controls the switching of the external circuit. An MCB is provided as a bypass switch to control the external lighting in case of a malfunction of the raspberry pi.

International Journal of Innovative Research in Science, Engineering and Technology

(An ISO 3297: 2007 Certified Organization)

Vol. 4, Issue 7, July 2015

Modules Description:

Power Saver Module: This is the main module of the proposed system.

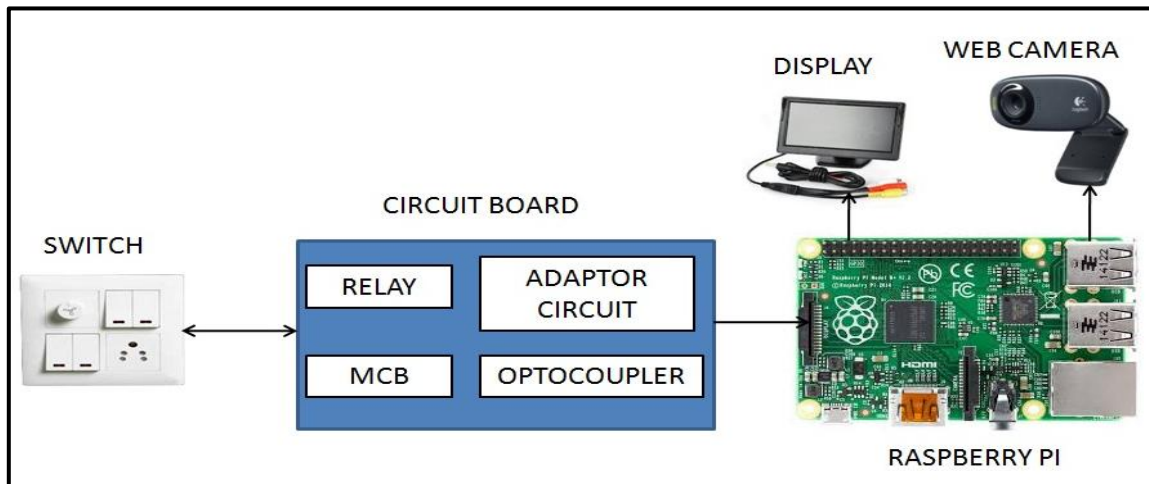

Fig.3: Power Saver Module

Fig.3 shows the block diagram of a Power Saver Module. A web camera is used to capture the images of a room and then compare these images with the human patterns that are sorted in the OpenCV software. If it fails to match then the power supply is disabled and lights and fans are turned OFF in the classroom which indicates that the classroom is unoccupied. This can reduce the bill to the extent of 50%.

Magic Lantern Module:

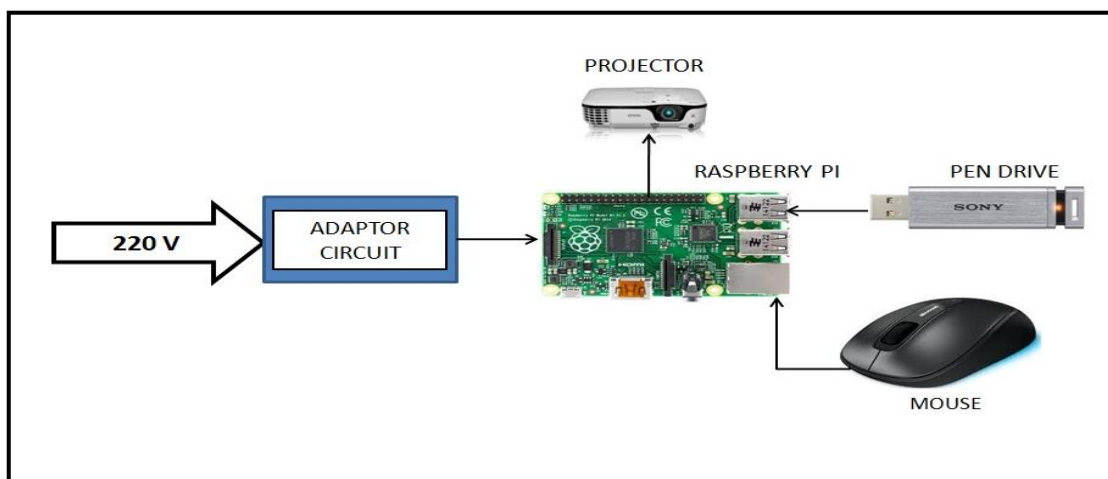

Fig.4: Magic Lantern Module

Fig.4 shows the block diagram of the Magic Lantern Module. This module helps to connect to a projector in the classroom, with the 2.0 USB ports and HDMI port available on the raspberry pi. This can be used for learning purposes like presentations, seminars, etc. and also for entertainment purpose like playing videos, images, etc.

International Journal of Innovative Research in Science, Engineering and Technology

(An ISO 3297: 2007 Certified Organization)

Vol. 4, Issue 7, July 2015

Remote Surveillance Module:

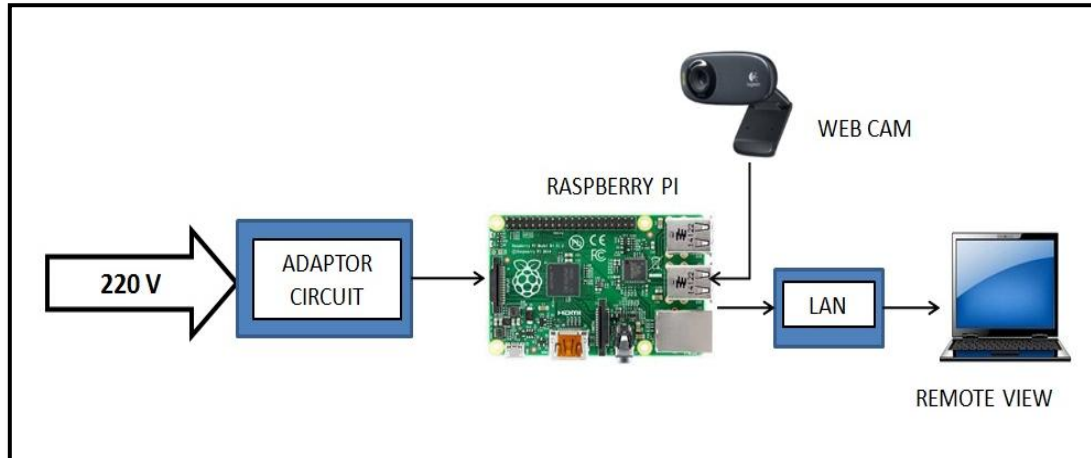

Fig.5: Remote Surveillance Module

Fig.5 shows the block diagram of the Remote Surveillance Module. This module is used to monitor the students in the classroom during regular classes, internal tests, external examinations, etc. This is done by using a web camera to capture the video and an Ethernet cable to transfer the captured video to a remote system.

Tocsin Module:

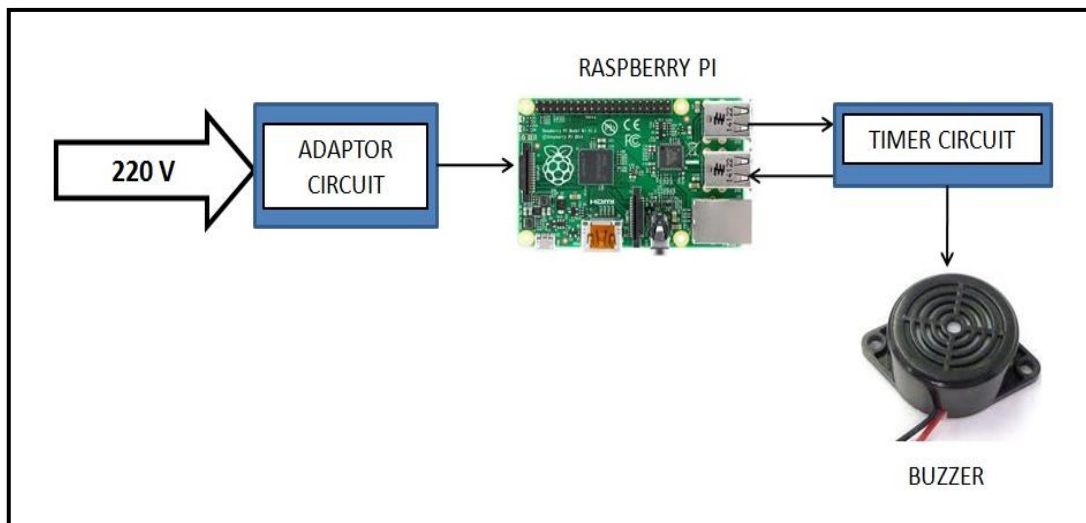

Fig.6: Tocsin Module

Fig.6 shows the block diagram of the Tocsin Module. This module is used to ring a bell / an alarm in the classroom to indicate the faculty regarding the end of the class. The faculty has to set the duration of the class that he / she have to take using a Potentiometer. After the time expiry the alarm rings. This helps other faculty to begin their sessions on time.

International Journal of Innovative Research in Science, Engineering and Technology

(An ISO 3297: 2007 Certified Organization)

Vol. 4, Issue 7, July 2015

AV Recorder Module (Recording of Seminars / Technical Talk): This module helps to record seminars and technical talks that are conducted in the institution by students, faculties and guest lectures. As a web camera is being used in the project, audio and video recording is possible.

Safe Guarder Module (Security of Classroom): This module helps to secure the classroom. Through LAN connections and a remote system, the classroom can be monitored for security issues and the same can also be recorded for processing later when needed.

Scheduler Module (Automatic shutdown of the system after college hours): This module helps in turning off the whole system after the college hours. Even though all the electrical consumables are turned off in the department the power supply will not be disabled. Using this system power can be disabled during the night hours with the help of the timer. This module helps in reducing the electricity cost overheads.

IV. RESULTS AND DISCUSSION

The following are the images of the system deployed in one of the class room of Department of MCA, BMS Institute of Technology & Management, Bengaluru.

METER READING'S					
INITIAL METER READING: 1.2 UNITS					
SL NO.	DATE	HOURS	OPENING READING	CLOSING READING	UNITS CONSUMED PER HOUR
01	17/04/15	9:00 - 10:00	1.2	2.0	0.8
02	17/04/15	10:00 - 11:00	2.0	2.7	0.7
03	17/04/15	11:00 - 12:00	2.7	3.4	0.7
04	17/04/15	12:00 - 01:00	3.4	4.1	0.7
05	17/04/15	01:00 - 02:00	4.1	4.8	0.7
06	17/04/15	02:00 - 03:00	4.8	5.5	0.7
07	17/04/15	03:00 - 04:00	5.5	6.2	0.7

Fig.7: Initial Meter Reading

An energy meter was installed initially to calculate the power consumption before using the proposed method. The readings taken thereof is shown in Fig.7

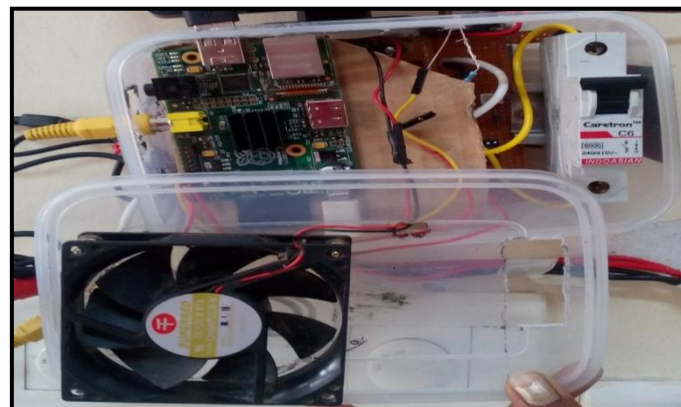

Fig.8: The Circuit Box with the Display

Fig.8 shows the circuit board connections along with the display. The entire device is packaged into a plastic case covered with a metal sheath.

International Journal of Innovative Research in Science, Engineering and Technology

(An ISO 3297: 2007 Certified Organization)

Vol. 4, Issue 7, July 2015

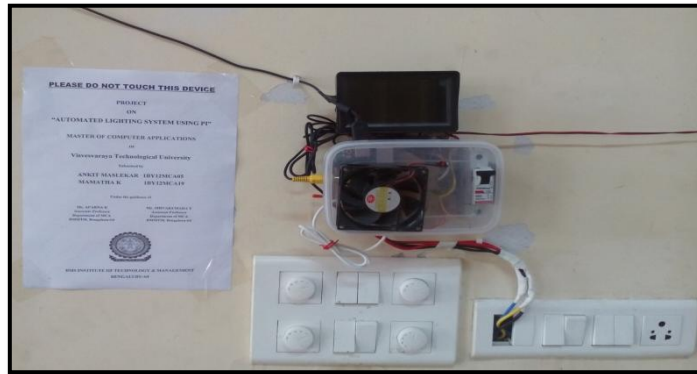

Fig.9: Switch Board in Class room after System is deployed

Fig.9 shows the switch board in the classroom after the installation of the proposed system using Raspberry Pi.

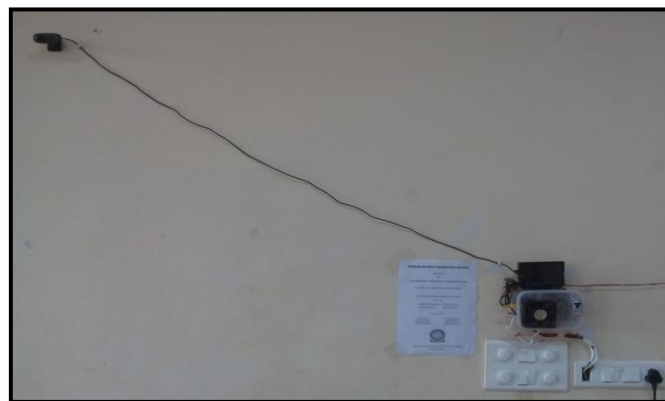

Fig.10: The Complete system along with the Web Camera

The web camera is installed in a very strategic location in the class room so that the human patterns could be captured very effectively and efficiently. Hence the entire Smart Lighting System implemented using Raspberry Pi is shown in the Fig.10

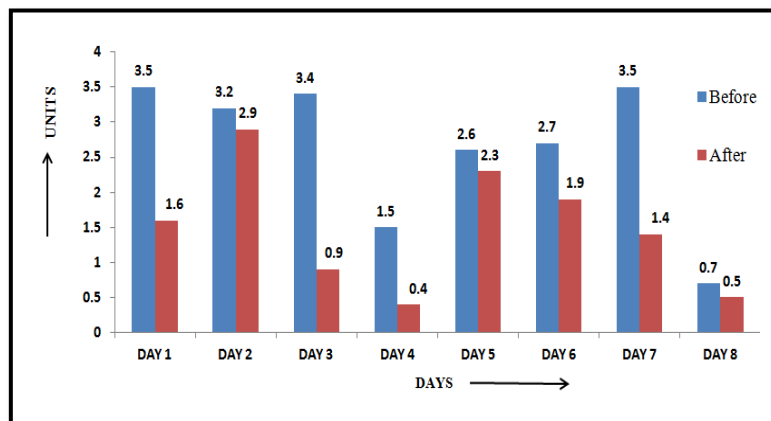

Fig.11: Energy consumed before and after the installation

International Journal of Innovative Research in Science, Engineering and Technology

(An ISO 3297: 2007 Certified Organization)

Vol. 4, Issue 7, July 2015

The system was tested to determine the energy consumed before and after the installation of the system. Fig.11 shows the units consumed on a day-to-day basis for a sequence of 8 days. It can be inferred from the graph that there is significant amount of energy conserved.

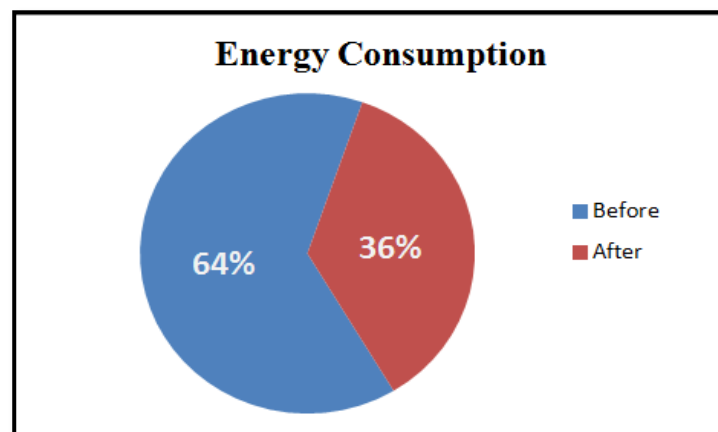

Fig.12: Pie Chart depicting the total Energy Consumption of the system

Fig.12 shows the difference in the percentage of energy consumption before and after implementation of the automated lighting system using Raspberry PI. It can be inferred from the pie chart that there is a drastic reduction of consumption of power. The results show that almost 50% of the power consumption can be saved.

V. CONCLUSION

The automatic lighting system turns OFF lights in the room when unoccupied. The average electric units consumed in the classroom before installing the system has been recorded with 2.7 units per day for 8 days and the average electric units consumed in the classroom after installing the system has been recorded with 1.5 units per day for 8 days. The main objective was to conserve energy and hence this has been achieved by saving 1.2 electric units for one classroom. The classroom was consuming 64% of electricity before deploying the system and after the deployment of the system we found that the consumption was reduced to 36%. It can be inferred from this that 50% of energy is conserved. This project, automated lighting system using Pi is a real time application. Though the end product turned out to be exactly what was brainstormed and designed, there is a still lot of scope for improvement.

REFERENCES

- [1] Raspberry Pi Foundation, UK registered charity 1129409 - <http://www.raspberrypi.org/help/>
- [2] Cellan Jones, Rory (5th May 2011), Peter (3rd June 2011), Bush, Steve (25th May 2011), "Dongle computer solve the programming on a TV" - http://en.wikipedia.org/wiki/Raspberry_Pi#/media/File:Raspberry_Pi_B%2B_top.jpg
- [3] <http://www.projectsof8051.com/automatic-room-light-controller-with-visitor-counter/>
- [4] Womack Electric Supply, 2011 - <http://www.womackelectric.com/wp-content/uploads/2011/05/P-S-Occupancy-and-Vacancy-Sensors-Catalog.pdf>
- [5] Akula Rahul, K.Haripriya, E.Sneha, "Smart Energy Management System Based on Zigbee Technology", 11th March 2015.
- [6] Dr. D.V.Pushpa Latha, Dr. K.R.Sudha, Swati Devabhaktuni, "PLC based Smart Street Lighting Control", IJ.Intelligent System and Applications, 2014, 01, 64-72.
- [7] Tutorialspoint - http://www.tutorialspoint.com/python/python_overview.html
- [8] OpenCV (Open Source Computer Vision) - <http://opencv.org/>
- [9] EEVblog electronics community forum - <https://www.google.co.in/webhp?sourceid=chromeinstant&ion=1&espv=2&ie=UTF-8#q=optocoupler+meaning>

International Journal of Innovative Research in Science, Engineering and Technology

(An ISO 3297: 2007 Certified Organization)

Vol. 4, Issue 7, July 2015

BIOGRAPHY



Ankit Maslekar received his BCA degree from K.L.E. Society's S. Nijalingappa College, Rajajinagar, Bengaluru, affiliated to Bangalore University, Bengaluru in the year 2012. Presently he is pursuing his MCA from BMS Institute of Technology & Management, Yelahanka, Bengaluru, affiliated to Visvesvaraya Technological University, Belgaum. He has presented many seminars on Grid Computing, Cloud Computing, Cloud Services, Hacking and Green Procurement at college level. His area of interests includes Computer Networks and Operating Systems



Aparna K is working as Associate Professor in the Dept. of MCA at BMS Institute of Technology & Management, Bangalore, affiliated to Visvesvaraya Technological University, Belgaum. She has received B.Sc degree in Computer Science from Bangalore University, MCA from VTU, Belgaum and M.Phil degree in Computer Science from Bharathidasan University, Tiruchirappalli and currently pursuing Ph.D in Computer Science at VTU in the area of Data Mining. She is a life member of CSI and ISTE and she has presented and published various papers in different national and international conferences. Her areas of research include Data Mining, Information Retrieval and MANET protocols.



Mamatha K received her BCA degree from K.L.E. Society's S. Nijalingappa College, Rajajinagar, Bengaluru, affiliated to Bangalore University, Bengaluru in the year 2012. Presently she is pursuing her MCA from BMS Institute of Technology & Management, Yelahanka, Bengaluru, affiliated to Visvesvaraya Technological University, Belgaum. She has also completed ASP.NET course from NIIT. She is proficient in some of the programming languages including C, C++ and Java.



Shivakumara T is working as Assistant Professor in the Dept. Of MCA at BMS Institute of Technology and Management, Bengaluru, affiliated to VTU, Belgaum. He received his B.Sc degree from Gulbarga University in 2000, followed by MCA degree from VTU, Belgaum in the year 2008 and MTech from KSOU in 2013. He has authored two books on OOPs concepts and Advanced Java Programming. He has also presented several papers in various National Conferences. He is also a member of ISTE.