

Design of a Micro-Grid System in Matlab/Simulink

Rajdeep Chowdhury¹, Tilok Boruah²P.G. Student, Department of Electrical & Instrumentation Engineering, Jorhat Engineering College, Jorhat, Assam,
India¹Assistant Professor, Department of Electrical & Instrumentation Engineering, Jorhat Engineering College, Jorhat,
Assam, India²

ABSTRACT: Micro-Grid(MG) is basically a low voltage (LV) or medium voltage (MV) distribution network which consists of a cluster of micro-sources such as photo-voltaic array, fuel cell, wind turbine etc. called distributed generators (DG's); energy storage systems and loads; operating as a single controllable system, able to operate in both grid-connected and islanded mode. In a micro-grid the DG's has sufficient capacity to carry all, or most of the load connected to the micro-grid. This paper presents the development of these micro-sources i.e photo voltaic array, fuel cell stack along with their power electronic interfacing circuits viz. boost converter, PWM inverter in Matlab/Simulink and finally combining these models to form a Micro-Grid. The system is so designed that it can be operated both in islanded as well as in grid connected mode. This project aims to lay groundwork which will allow for further investigation and for the development of a more sophisticated micro-grid model, so as to allow for a full understanding of how MG's behave.

KEYWORDS: Micro-grid, islanded mode, grid-connected mode, boost converter, PWM inverter.

I. INTRODUCTION

As energy generation and distribution companies compete in the market place, we have seen an increasing interest in renewable and alternative energy sources. In addition to this competition, companies are seeking demands from customers for higher quality and cleaner electricity. Also, considering the worlds coal stocks are reducing and the creation of legislation which is pushing for greener energy solutions, we are led to seek new energy generation methods. One solution which is currently attracting attention is Micro-Grid systems [1]-[2].

A Micro-Grid is a low voltage or medium voltage distribution network which consists of a cluster of micro sources/distributed generators, energy storage systems and loads, operating as a single controllable system. In a MG, the distributed generators should have sufficient capacity to carry all, or most, of the load connected to the MG. Distributed generators are located at strategic points, normally at the distribution level, near load centres, and used for capacity support, voltage support and regulation, and line loss reduction [2].

The micro-sources or distributed generators are usually made of many new technologies, e.g. fuel cell, photo-voltaic system and several kinds of wind turbines. These units having small capacities are interfaced with power electronics and are placed at the consumer sites. Power electronics provides the control and flexibility required by the micro grid system. The inclusion of energy storage systems (batteries/flywheels/super capacitors) in a Micro grid system allows the excess power produced, to be stored or alternatively the excess power could be put into the main grid [3]-[4].

Micro-grid is inevitable in future due to its obvious advantages in reduced central generation capacity, increased utilization of transmission & distribution capacity, enhanced system security and reduced CO₂ emission. However, micro-grid adds a number of complexities in control and protection aspects in a traditional distribution system.

International Journal of Innovative Research in Science, Engineering and Technology

(An ISO 3297: 2007 Certified Organization)

Vol. 4, Issue 7, July 2015

The paper is organized as follows: Section II describes the modelling of photo voltaic (PV) systems and Proton Exchange Membrane fuel cell (PEMFC) along with their power electronic interfacing circuits in Matlab/Simulink. After verifying the characteristics, these models are combined by synchronizing the voltage generated to form a Micro-grid system that is given in Section III, which is capable of operating both in grid-connected as well as in islanded mode. Section IV presents simulation results showing results of synchronous voltage and power generated. Finally, Section V presents conclusion.

II. RELATED WORK

MODELING OF PV SYSTEM IN MATLAB/SIMULINK:

Among the renewable energy resources, the energy through the photovoltaic (PV) effect can be considered the most essential and prerequisite sustainable resource because of the ubiquity, abundance, and sustainability of solar radiant energy. A photovoltaic system uses one or more solar modules or panels to convert solar energy to electrical energy. This conversion occurs in materials which have the property to capture photon and emit electrons. The main material used in PV system is Silicon. Basically, the components of PV system include solar panels, mechanical and electrical connections and means of modifying the electrical output we get [5].

Before modelling a generalized PV array system an attempt has been made to model a PV array system in Matlab/Simulink environment using solar cells available in the Simulink library. However this model suffers from the drawback that it is capable of producing very less power after connecting a lot of solar cells in series-parallel manner. Hence, it becomes a tedious job to implement this model. A generalized PV model is built using Matlab/ Simulink to illustrate and verify the nonlinear I-V and P-V output characteristics of PV module. The proposed model is implemented and is shown in Fig.2. In order to make the generalized model easier to use and understand, we used an image file of PV icon as a masking icon. The user-friendly icon is shown in Fig.2(c). In addition, the masked model is designed to have a dialog box in which the parameters of PV module can be configured in the same way for the Simulink block libraries. After verifying the characteristics of PV system in Matlab, its model is implemented in Simulink using the equations described below. The system is first designed for a PV module (shown in Fig.2 (a)) and then masked to connect several PV modules to form PV array (shown in Fig.2 (c)) with voltage as output and solar irradiance as input at a particular temperature of 25°C. An important decision with the array was to decide to model it either with current or voltage as the output, voltage was chosen because we are more concerned in modelling a MG using DGs which can produce voltage as output connected with power conditioning devices which regulates the output voltage.

In this modelling the physical system is converted to computer codes and characteristics are plotted. To describe the behaviour of the physical PV cell, The PV model is chosen by the researchers. Most commonly used model is a single diode model. In the Fig.1(a) shown below the equivalent circuit of the general model consists of a photo current, a diode, a parallel resistor expressing a leakage current, and a series resistor describing an internal resistance to the current flow is shown.

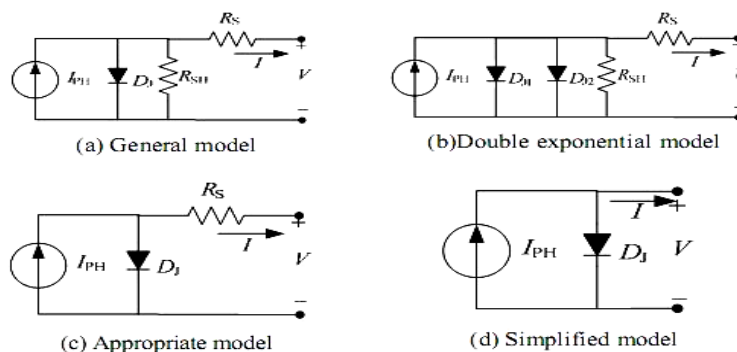

International Journal of Innovative Research in Science, Engineering and Technology

(An ISO 3297: 2007 Certified Organization)

Vol. 4, Issue 7, July 2015

Fig.1. Equivalent circuit model of PV cell

Fig.1 (b) shows the double exponential model which is composed of a light-generated current source, two diodes, a series resistance and a parallel resistance. On putting $R_{SH} = \infty$ in the general model we get the appropriate model shown in Fig.1(c). Putting $R_S = 0$ and $R_{SH} = \infty$ in the general model we get the simplified model of the PV cell shown in Fig.1 (d).

The V-I characteristic equation of a solar cell is given as, $I = I_{PH} - I_S [\exp(q(V + IR_S)/KT_C A) - 1] - (V + IR_S)/R_{SH}$, where I_{PH} = photocurrent, I_S = cell saturation current, $q = 1.6 \times 10^{-19}$ C, $k = 1.38 \times 10^{-23}$ J/K is a Boltzmann's constant, T_c = cell's working temperature, A = ideal factor, R_{SH} = shunt resistance, R_s = series resistance [6].

The photo current mainly depends on the solar insolation and cell's working temperature, which is given by, $I_{PH} = [I_{SC} + K_I (T_C - T_{Ref})] \lambda$, where I_{SC} is the cell's short-circuit current at a 25°C and 1 kW/m^2 , K is the cell's short-circuit current temperature coefficient, T_{Ref} is the cell's reference temperature, and λ is the solar insolation in kW/m^2 . On the other hand, the cell's saturation current varies with the cell temperature, which is described as, $I_S = I_{RS} (T_C/T_{Ref})^3 \exp[qE_G(1/T_{Ref} - 1/T_C)] \text{ kA}$

where I_{RS} is the cell's reverse saturation current at a reference temperature and solar radiation, E_G is the band-gap energy of the semiconductor used in the cell [6].

For an ideal PV cell, there is no series loss and no leakage to ground, i.e., $R_S = 0$ and $R_{SH} = \infty$.

Hence the V-I characteristic of the cell becomes, $I = I_{PH} - I_S [\exp(qV/kT_C A) - 1]$.

Since a typical PV cell produces less than 2W at 0.5V approximately, the cells must be connected in series-parallel configuration on a module to produce enough high power. A PV array is a group of several PV modules which are electrically connected in series and parallel circuits to generate the required current and voltage. If N_p =number of solar cells in parallel & N_s =number of solar cells in series, then the terminal equation of current & voltage of the PV array becomes, $I = N_p I_{PH} - N_p I_S [\exp(q(V/N_s + IR_S/N_p)/KT_C A) - 1] - (N_p V/N_s + IR_S)/R_{SH}$.

Using these equations a generalized PV array system is build in Matlab/Simulink to illustrate and verify the nonlinear I-V and P-V output characteristics of PV module. The proposed model is implemented and is shown in Fig.2 (a). Fig 2(b) shows the subsystem implementation of the diode block. In order to make the generalized model easier to use and understand, we used an image file of PV icon as a masking icon. The user-friendly icon is shown in Fig.2(c). In addition, the masked model is designed to have a dialog box in which the parameters of PV module can be configured in the same way for the Simulink block libraries.

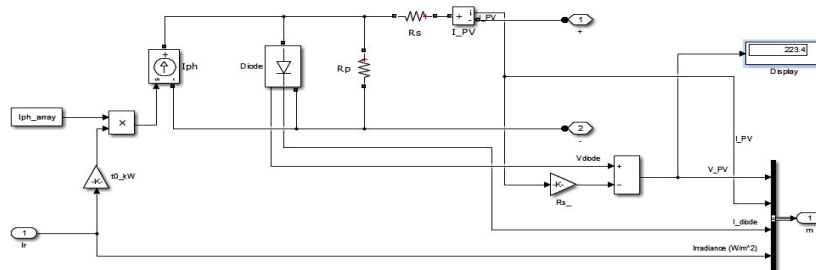
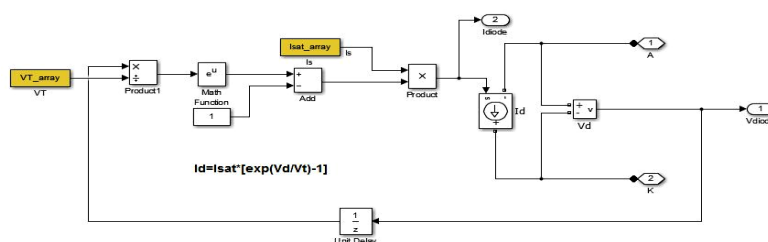

Fig.2 (a).Sub-system implementation of generalized PV array.



International Journal of Innovative Research in Science, Engineering and Technology

(An ISO 3297: 2007 Certified Organization)

Vol. 4, Issue 7, July 2015

Fig.2 (b).Sub-system implementation of the diode block.

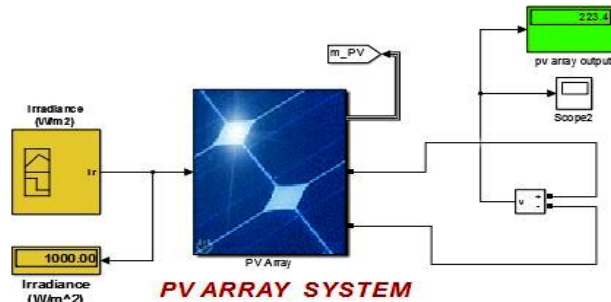

Fig. 2(c). Masked implementation of generalized PV array

The parameters along with the values used in modelling the PV Array are given in the table below:

Parameters	Values
Number of Solar cells per module	72
Number of series connected modules per string	5
Number of parallel strings	66
Solar irradiance(input)	1000W/m ²
Output Voltage	223Volts
Output power	88KW(max)
Operating temperature	25°C
V _{oc}	44.4999 Volts
I _{sc}	8.19978 A
V _{mp}	35 Volts
I _{mp}	7.70979 A

The parameters chosen for designing one PV module are given below:

$R_s=0.32025\text{ohm}$, $R_p=2562.3\text{ohms}$, $I_{sat}=8.8992e-07\text{ A}$, $I_{ph}=8.2979\text{ A}$, Q_d (diode quality factor) =1.5.

The characteristics of PV array obtained at the scope & simulation results are shown in section IV.

MODELING OF PEMFC SYSTEM IN MATLAB/SIMULINK:

In the near future, some fuel cell systems could be an accessible and attractive alternative to conventional electricity generation and vehicle drives. The polymer electrolyte membrane (interchangeably called proton exchange membrane, PEM) fuel cell systems can be made in mW to kW capacities; hence a wide range of applications can be covered by this type of fuel cell. This is a major advantage of this type of fuel cell, because once the technology was developed it can be more or less easily scaled up or down for various applications. PEM fuel cell has attracted a great deal of attention as a potential power source for automobile and stationary applications due to its low temperature of operation, high power density and high energy conversion efficiency. Great progress has been made over the past twenty years in the development of PEM fuel cell technology. However, there are still several technical challenges that need to be addressed before commercialization of PEM fuel cell [7]-[8].

Since, this fuel cell block is available in Simulink library; this block is used to model the Micro-Grid system [7]. However, to regulate the fuel cell output voltage and to improve the performance of the PEMFC system, a simple open loop boost converter interfaced with PEM fuel cell is designed in Simulink environment as shown,

International Journal of Innovative Research in Science, Engineering and Technology

(An ISO 3297: 2007 Certified Organization)

Vol. 4, Issue 7, July 2015

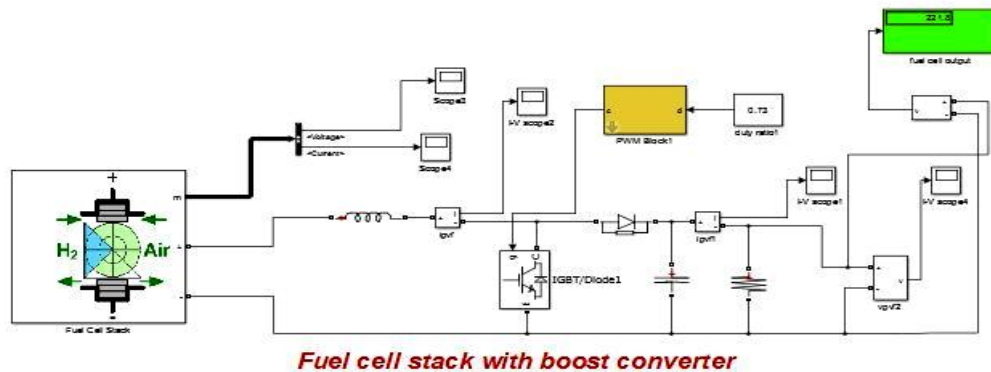

Fig.2 (d). PEMFC coupled with open-loop boost converter

Here the output voltage of the open-loop boost converter is a function of the duty cycle of the IGBT/Diode (switch). By regulating the duty cycle to 0.73, the value of the output voltage of the fuel cell stack is boosted from 45Volts to 222-224 Volts. Moreover, a capacitor of 4000 μ F is used at the output to filter the unwanted harmonics. The extracted output waveform seen at the scope is as shown in section IV.

III. COMPLETE SIMULINK MODEL OF A MICRO-GRID SYSTEM

After implementing all these models in Matlab/Simulink, the models are combined together to form a Micro-Grid system, shown in Fig. 3(a). The generated DC voltage from these sources is synchronised to a particular DC voltage (220V approx.), so that one three phase voltage source PWM inverter can be used for the whole system. This AC voltage obtained after filtration is of 200Volts. In order to operate the MG in grid-connected mode a three phase transformer connected in Delta-star configuration is designed which steps up the 200V AC to 400V, such that power can be fed to the utility grid [9]-[11].

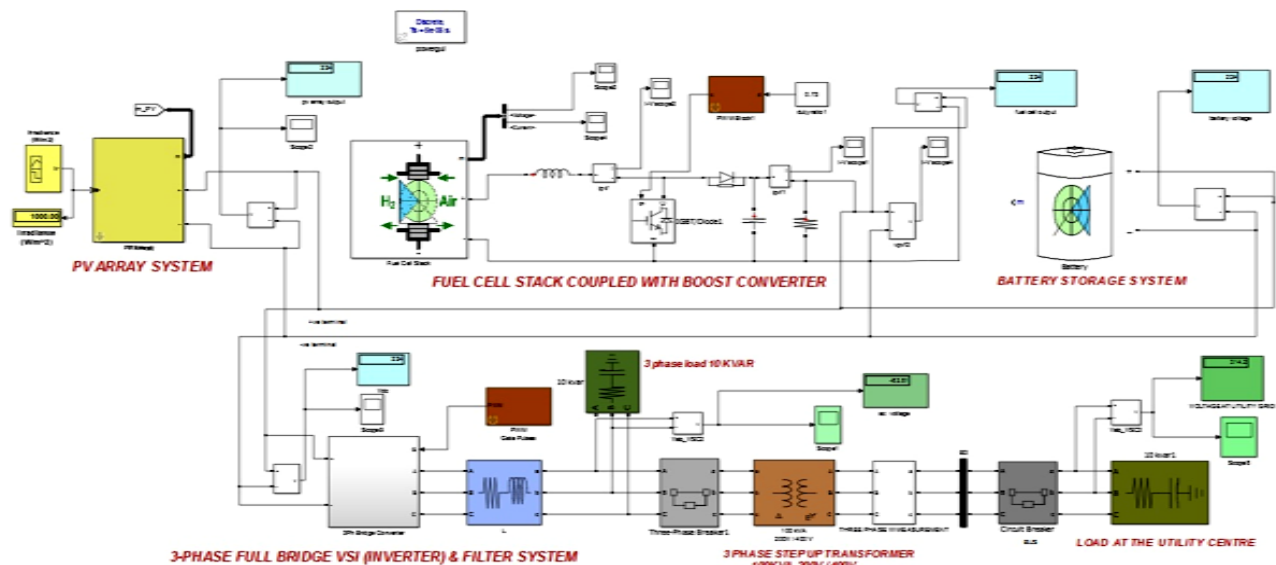

Fig.3 (a). Complete simulink model of a Micro-grid system

International Journal of Innovative Research in Science, Engineering and Technology

(An ISO 3297: 2007 Certified Organization)

Vol. 4, Issue 7, July 2015

The designed Micro-Grid is capable of supplying approx. 115KW of power, operating in islanded as well as in grid-connected mode.

The three phase PWM inverter used in designing the MG is modeled using six MOSFETS, triggered by PWM pulses which is shown in Fig.3 (b). This three phase PWM Voltage source inverter inverts the generated DC voltage (220V) to 200V A.C. The inverted voltage is further filtered by an LC filter circuit, which removes the harmonics and we obtain a pure AC waveform at the output. The extracted output waveform is shown in section IV.

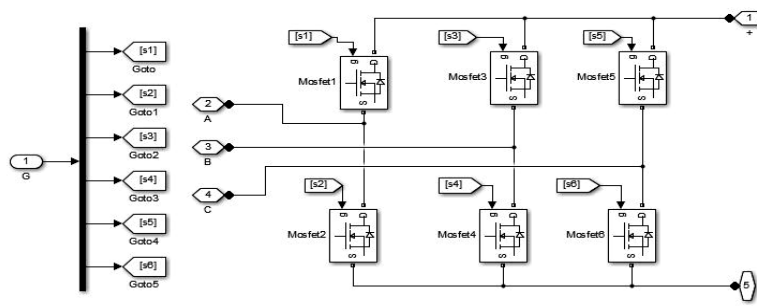

Fig.3 (b). Sub-system implementation of PWM voltage source inverter

In order to operate the Micro-Grid in grid-connected mode, a simple control logic circuit is designed to prevent backflow of power to the MG. The designed circuit shown in Fig. 3(c) is installed near to the utility grid and it disconnects the MG from the utility grid (with the help of circuit breakers) if there is any mismatch of voltage and frequency between the MG and the utility grid.

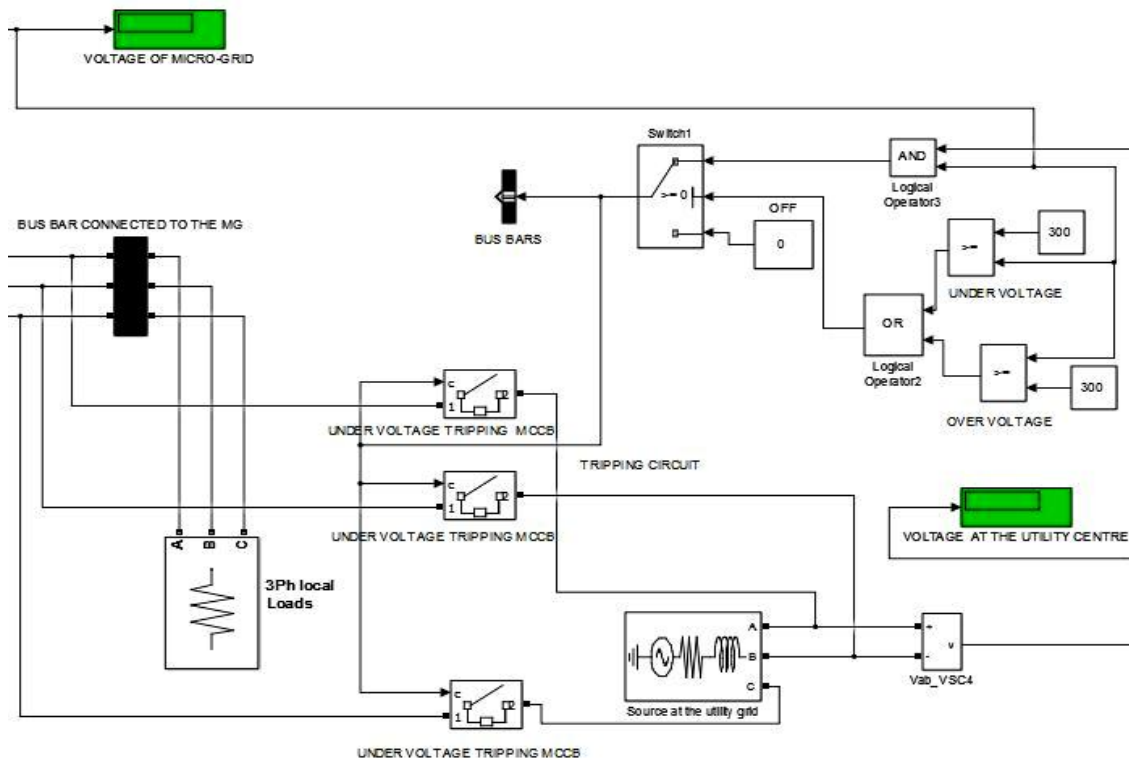

Fig. 3(c) Simulink model of control logic circuit installed near to the utility grid.

IV. EXPERIMENTAL RESULTS

Figure 4(a) shows the I-V &P-V characteristics obtained from the PV array, while Figure 4(b) shows the extracted output waveform of the PV system. Fig. 4(c) shows the output waveform of the fuel cell stack obtained after boosting the DC voltage by open loop boost converter. Fig 4(d) shows the inverted AC voltage generated (200V) after inverting the obtained DC voltage.

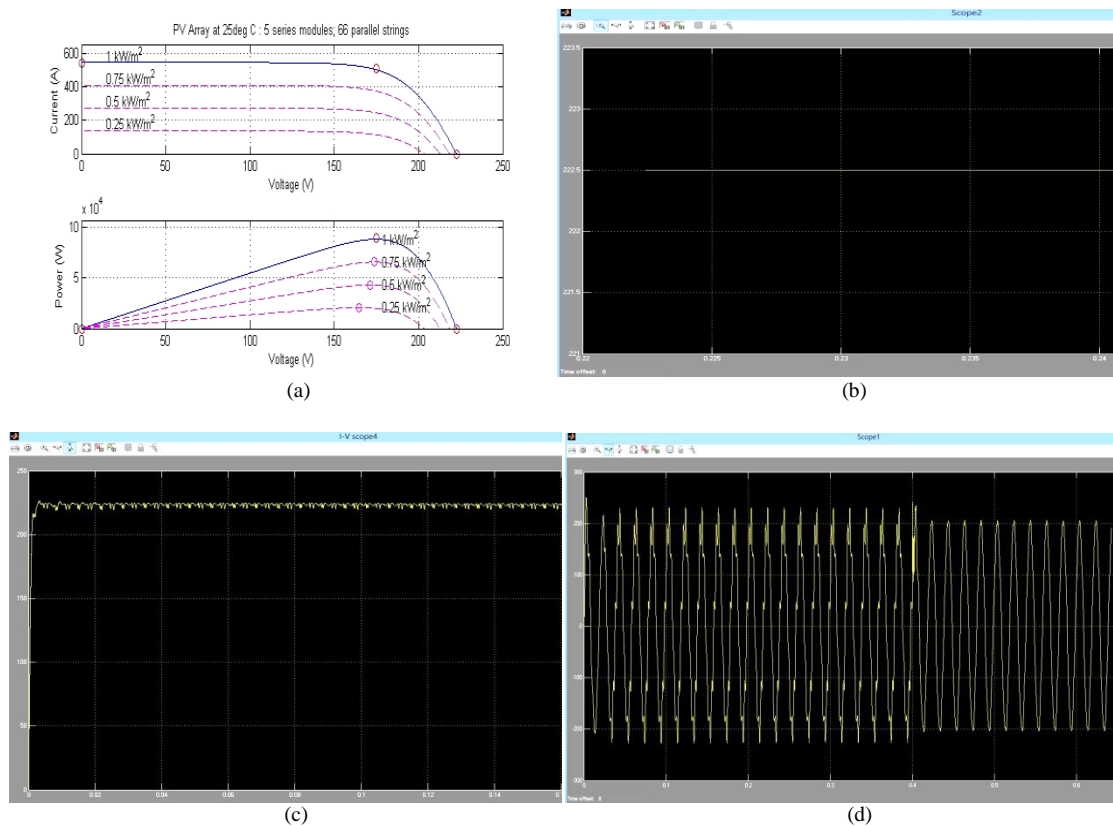

Fig. 4 Simulation results (a) I-V & P-V characteristics of PV array (b) extracted output waveform of the PV system (c) extracted output waveform of the fuel cell stack after boosting the DC voltage (d) extracted output waveform of the A.C voltage generated from the Micro-Grid.

The figures 4(b) & 4(c) shows that the voltages obtained by PV & PEMFC systems are synchronized at a particular voltage of 222Volts (D.C) approx. so that a single inverter can be used for the whole system making it more economical.

The data's of the results obtained are summarised below:

1. SOLAR IRRADIATION (input): 1000W/m²
2. PV OUTPUT VOLTAGE: 222-224Volts D.C
3. PV OUTPUT POWER: 88KW
 - a. Solar cells per module required :72
 - b. Number of series connected modules per string: 5
 - c. Number of parallel strings: 66
4. PEMFC OUTPUT VOLTAGE: 45Volts DC

International Journal of Innovative Research in Science, Engineering and Technology

(An ISO 3297: 2007 Certified Organization)

Vol. 4, Issue 7, July 2015

5. PEMFC OUTPUT POWER: 6KW
6. PEMFC OUTPUT VOLTAGE(WITH BOOST CONVERTER): 220-224Volts D.C
7. BATTERY VOLTAGE: 220Volts D.C
8. OUTPUT VOLTAGE OF THE MICRO-GRID: 200Volts A.C (islanded mode)
9. OUTPUT VOLTAGE OF THE MICRO-GRID: 400Volts A.C(grid-connected)
10. OUTPUT POWER OF THE MICRO-GRID: 115KW(approx.)

V. CONCLUSION

A Micro-Grid (MG) with approx. 115kW capacity has been designed to operate both in islanded as well as in grid-connected mode. The designed system is economical, because it uses a single 3-phase inverter for the whole system. Moreover, transformer has been eliminated to supply power to its local loads. It is expected that this model will lay the ground work for developing a highly sophisticated Micro-Grid.

REFERENCES

- [1] N. Hatzaiargyriou, H. Asano, R. Iravani, C. Marnay, "Micro-grids: An overview of ongoing research, development and demonstration projects", IEEE Power and Energy magazine, pp. 78-94, July/August 2007.
- [2] T.E Hoff, H.J Wenger, and B.K. Farmer, "Distributed generation-An alternative to electric utility investments in system capacity", Energy Policy, 24(2):137-147, 1996.
- [3] B. Lasseter, "Micro grids-distributed power generation", IEEE Power Engineering Society Winter Meeting, 2001, volume 1, pages 146-149, Columbus, Ohio, Feb 2001.
- [4] R. H. Lasseter, "Microgrids", IEEE Power Engineering Society Winter Meeting, Vol. 01, pp. 305-308, NewYork, NY, 2002.
- [5] M.S. Mahmodian, R. Rahmani, E.Taslimi, S. Mekhilef, "Step By Step Analyzing, Modeling and Simulation of Single and Double Array PV system in Different Environmental Variability", 2012 International Conference on Future Environment and Energy IPCBEE vol.28 IACSIT Press, Singapore.
- [6] Huan-Liang Tsai, Ci-Siang Tu, and Yi-Jie Su, "Development of Generalized Photovoltaic Model using MATLAB/SIMULINK", Proceedings of the World Congress on Engineering and Computer Science, WCECS 2008, October 22-24, 2008, San Fransisco, USA.
- [7] Zehra Ural, Muhsin Tunay Gençoglu and Bilal Gumus, "Dynamic Simulation of a Pem Fuel Cell System", Proceedings 2nd International Hydrogen Energy Congress and Exhibition IHEC 2007 Istanbul, Turkey, 13-15 July 2007.
- [8] Faheem Khan, Arshad Nawaz, Malik Ansar Muhammad, Muhammad Ali Khadim, "Review and Analysis of MATLAB Simulink model of PEM Fuel Cell Stack", ACEEE International Journal on Electrical and Power Engineering, Vol. 1, No. 1, Jan 2010.
- [9] G. Venkataramanan and M. Illindala, "Micro grids and sensitive loads", IEEE Power Eng. Soc. Winter Meeting, 2002, volume 1, pages 316-322, 2002.
- [10] Yassin M. Y. Hasan and Lina J. Karam, "Morphological Text Extraction from Images", IEEE Transactions on Image Processing, vol. 9, No. 11, 2000.
- [11] R. H. Lasseter and P. Paigi, "Microgrid: a conceptual solution," in Power Electronics Specialists Conference, 2004, PESC 04. 2004 IEEE 35th Annual, 2004, pp. 4285-4290 Vol.6.