

Optimization of Machining Parameters for Development of 5083 Aluminium Nano Structure through Hot ECAP

Praveen Kumar P¹, Rajmohan G²

Assistant Professor, Department of Mechanical Engineering, Dhaanish Ahmed College of Engineering, Chennai, Tamilnadu , India^{1,2}

ABSTRACT: This paper derive on the behavior of Al 5083 alloy and the responsibility was analysed by optimization of machining parameters in turning operation Using lathe. The Al 5083 is machined by Tungsten carbide tool using input parameters such as speed, feed, depth of cut & tool angle. The Maximum chip length, tool wear & Metal removal rate was identified for each and every input parameters. The relationship between input & output parameters was analysed using mathematical model & the significant also analysed by Anova. Then the collected chips were converted as a Nano particle by using ball milling. This is consolidated as a billet by applied load through hot ECAP process. Then the microstructure & hardness, of billet was analysed. The micro structured evolution and mechanical properties were studied the above conditions.

1. INTRODUCTION

In this optimization process the input parameters for turning &run sheet will create using DESIGN EXPERT 8 software. The 5083 Al is machined by Tungsten carbide tool with giving various machining parameters in run sheet. In each and every input parameter values to find The Maximum chip length, tool wear & Metal removing rate will be calculate. The collected chips are converted as a Nano particles by ball milling. This is associated as a billet by applying load through hot ECAP. The microstructure of the billet will calculate & surface roughness will measure via turning in lathe.5083 Al alloy is an aluminium alloy suitable for cryogenic applications down to design temperature of -165° C (-265° F), since alloys of this type do not show the ductile-brittle conversion singularity. This alloy is also common for the naval applications such as body materials for ships, underwater vehicles etc. this alloy is mostly used as marine alloys.5083 Al alloy also retains exceptional strength later welding. It has the maximum strength of the non-heat treatable alloys but is not recommended for use in temperatures in excess of 65°C.

II. EXPERIMENTAL METHODS

2.1 DESIGN EXPERT SOFTWARE



Fig. 2.1 Design Expert 8

International Journal of Innovative Research in Science, Engineering and Technology

(An ISO 3297: 2007 Certified Organization)

Vol. 4, Issue 6, June 2015

Identify the breakthrough factors for process or product improvement. Design-Ease software helps us set up and analyze overall factorial, two-level factorial, fractional factorial (up to 31 variables) and Plackett-Burman designs (up to 31 variables). With these designs we can rapidly display for critical factors and their interactions. We can also do numerical optimization.

Table- 1 COMPARISON BETWEEN DOE & TAGUCHI METHOD

| ASPECT | DESIGN OF EXPERIMENTS | TAGUCHI METHOD |
|--------------------------|-----------------------|----------------|
| Knowledge of the process | Not required | Required |
| Number of test runs | Large | Smaller |
| Noise factors | Not included | Included |
| Variability of System | Ignored | Included |
| Confirmation runs | Not required | Advisable |

Table:2 Input Parameter values in 2 level

| Parameters | Min Range | Max Range |
|-------------------|-----------|-----------|
| Speed (rpm) | 220 | 350 |
| Feed (mm/rev) | 0.20 | 0.40 |
| Depth of cut (mm) | 0.30 | 0.60 |
| Tool angle (°) | 45 | 70 |

2.2 EFFECT OF PROCESSING ROUTES ON

2.2.1. Metal removal rate

Material removal rate and machining time is calculated using formulas.

$$MRR = \pi \times D \times d \times f \times N$$

Where D is Original diameter of the work piece

d is depth of cut

f is feed rate

N is speed

$$Machining\ time = L / f \times N$$

Where L is overall length of the work piece

f is feed rate N is speed

2.2.2. Tool wear

Tool wear describes the gradual failure of cutting tools due to consistent operation. Tool makers microscope is used for measuring the tool wear.

2.2.3. Maximum chip length

Collection of chips in which are maximum length in each & every machining operation is called as a maximum chip length.

2.2.4. Micro structure

Microstructure is defined as the structure of a prepared surface or thin foil of material as revealed by a microscope above 25×Exaggeration. The microstructure of a material can be broadly classified into metallic polymeric, ceramic and composites. It can strongly influence physical properties of materials. There are two types of microscopy's are used for measuring the microstructure of the materials. Hardness of a material as determined by forcing an indenter such as a Vickers or Knoop indenter into the surface of the material under 15 to 1000 kgf load. The indentations are so slight that they must be restrained with a microscope. Accomplished of defining hardness of different micro integrals within a

International Journal of Innovative Research in Science, Engineering and Technology

(An ISO 3297: 2007 Certified Organization)

Vol. 4, Issue 6, June 2015

structure, or assessing precipitous hardness gradients such as those encountered in casehardening. Conversions from microhardness values to tensile strength and other hardness scales (e.g. Rockwell) are available for many metals and alloys.

Table:3 Run sheet-1 with Input Parameters & Responses for 2 level full factorial

| SL NO | SPEED (rpm) | FEED (mm/rev) | DOC (mm) | ANGLE (°) | MAX CHIP LENGTH (mm) | MRR Cm ³ /min | TOOL WEAR (mm) |
|-------|-------------|---------------|----------|-----------|----------------------|--------------------------|----------------|
| 1 | 350 | 0.20 | 0.60 | 70 | 410 | 42 | 0.0692 |
| 2 | 220 | 0.40 | 0.60 | 70 | 370 | 52.8 | 0.071 |
| 3 | 350 | 0.40 | 0.30 | 45 | 438 | 42 | 0.19 |
| 4 | 220 | 0.20 | 0.30 | 45 | 392 | 13.2 | 0.21 |
| 5 | 350 | 0.20 | 0.30 | 70 | 175 | 21 | 0.24 |
| 6 | 220 | 0.20 | 0.60 | 45 | 143 | 26.4 | 0.0657 |
| 7 | 220 | 0.40 | 0.30 | 70 | 161 | 26.4 | 0.11 |
| 8 | 350 | 0.40 | 0.30 | 70 | 174 | 42 | 0.15 |
| 9 | 350 | 0.20 | 0.60 | 45 | 270 | 42 | 0.744 |
| 10 | 220 | 0.20 | 0.30 | 70 | 246 | 13.2 | 0.13 |
| 11 | 220 | 0.40 | 0.60 | 45 | 232 | 52.8 | 0.0751 |
| 12 | 220 | 0.20 | 0.60 | 70 | 269 | 26.4 | 0.0792 |
| 13 | 350 | 0.40 | 0.60 | 70 | 218 | 84 | 0.8115 |
| 14 | 350 | 0.20 | 0.30 | 45 | 239 | 21 | 0.19 |
| 15 | 350 | 0.40 | 0.60 | 45 | 178 | 84 | 0.8311 |
| 16 | 220 | 0.40 | 0.30 | 45 | 169 | 26.4 | 0.16 |

According to full factorial approach the number of treatment combinations = 2^n ($2^4 = 16$)

Table:4 RUN SHEET-2 FOR 2 LEVEL HALF FACTORIAL

| SL NO(runs) | SPEED(rpm) | FEED(mm/rev) | DOC(mm) | ANGLE(°) |
|-------------|------------|--------------|---------|----------|
| 1 | 350 | 0.40 | 0.60 | 70 |
| 2 | 350 | 0.20 | 0.30 | 70 |
| 3 | 220 | 0.40 | 0.30 | 70 |
| 4 | 350 | 0.20 | 0.60 | 45 |
| 5 | 220 | 0.20 | 0.30 | 45 |
| 6 | 220 | 0.40 | 0.60 | 45 |
| 7 | 350 | 0.40 | 0.30 | 45 |
| 8 | 220 | 0.20 | 0.60 | 70 |

According to Half factorial approach the number of treatment combinations = 2^{n-1} ($2^{4-1} = 2^3 = 8$)

2.3 PREPARATION OF SAMPLES

Most suitably equipped metalworking lathes used in turning operation. The 5083Al is machined by Tungsten carbide tool using various machining constraints. The Maximum chip length, tool wear & Metal removal rate will be computed in each and every input parameter.

International Journal of Innovative Research in Science, Engineering and Technology

(An ISO 3297: 2007 Certified Organization)

Vol. 4, Issue 6, June 2015

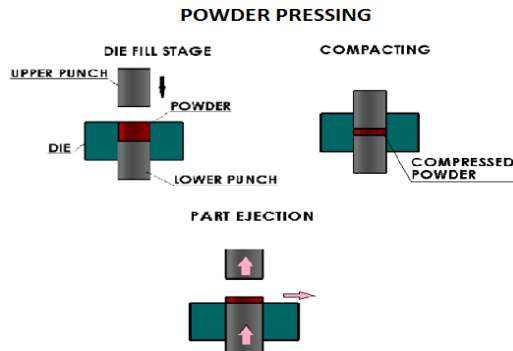

Fig: 2.2 PM compaction process

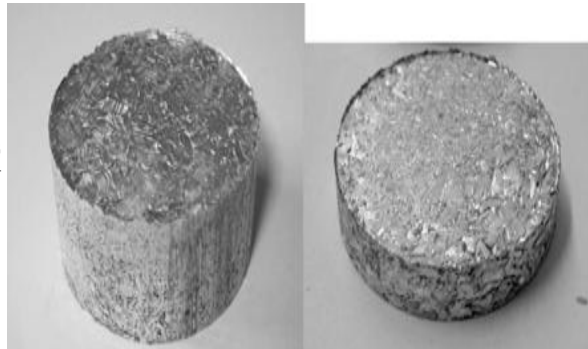

Fig: 2.3 Prepared Specimen

The collected chips are filled inside the ball mill when it brings to rotate the chips are form as a powder due to random striking of the balls. A ball mill is used to grind materials into extremely fine powder for use in mineral dress up operations, pigments, pyrotechny, ceramics and quality a 3D printing technology. Ball mill is a horizontal cylindrical device. It rotates to the horizontal axis, which contains number of equal size ironstone balls, flint pebbles and stainless steel balls. Powder metallurgy process are preferred to make a samples in a controlled atmosphere.

2.4 ECAP DIE:

The photograph of the die used for ECAP is shown below. The die is split type and the channel angle is 90° with a corner angle at the channel intersections is 20° . The semicircular 90° channel is present in the two rectangular blocks which can be fastened together to form a single channel, two additional plates were used to hold the die during the process

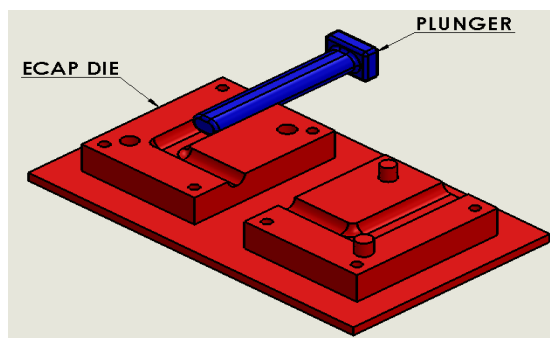

Fig. 2.4 ECAP Die

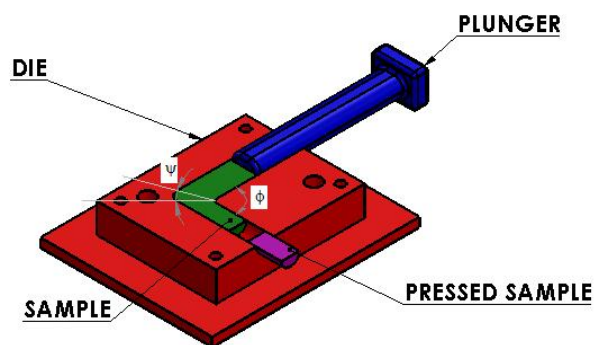

Fig. 2.5 ECAP process

2.5 EQUAL CHANNEL ANGULAR PRESSING PROCESS

The ECAP die is composed of two channels with identical rectangular cross sections connected through the intersection at a specific angle, usually 90° , 8° , 9° , 10° , and 11° . The cross section can also be round or square. The work piece is machined to aptinside the channel and extruded through two intersecting channels with the same cross section using a plunger (Figure 2.4). During the ECAP process, adequate lubrication is essential because of frictional effects, tool attrition and the loads required for plastic deformation. One important improvement of the ECAP process is that it can be repeated several times without changing the dimensions of the piece of work, and the applied strain can be increased to any level. These advantages mean that the severe strains that can be applied and a simple shear deformation mode contribute to the strong and unusual properties of the material produced.

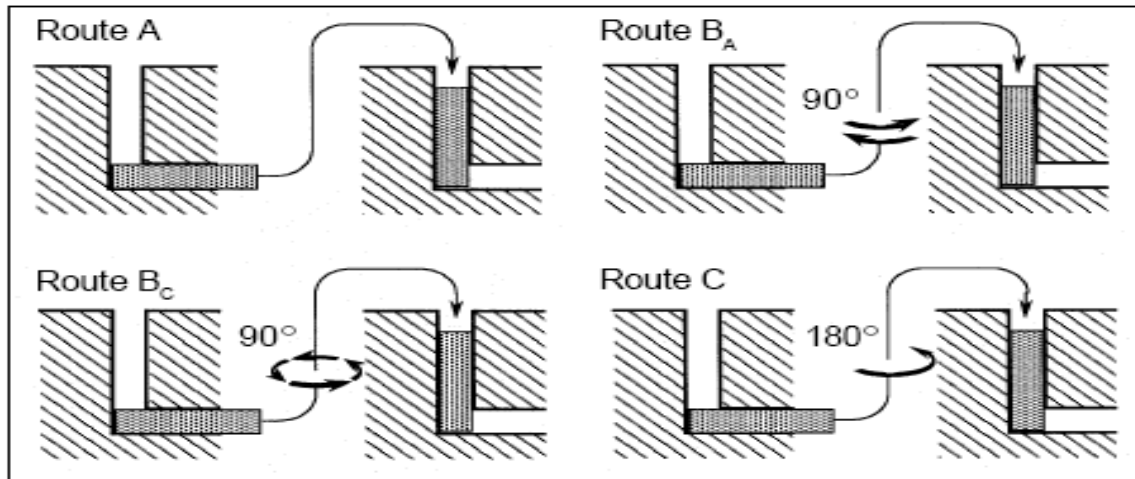

Fig. 2.6 Process Routes

III. TESTING

The Vickers test is often easier to use than other hardness tests since the required calculations are independent of the size of the indenter. The unit of hardness is the Vickers Pyramid Number (HV) or Diamond Pyramid Hardness (DPH). The hardness number is determined by the load over the surface area of the indentation. The prepared billet sizes to be low in length & diameter so the vicker's hardness was taken for the each & every billets. For high-resolution information on metallurgical microstructures, electron microscope methods can be employed. This can tolerate for direct remark of atomic-scale features such as very fine precipitation response dislocations or grain-boundary interfaces. Such methods may be acute in defining parameters such as solid state diffusivities.

3.1 ANOVA (Analysis Of Variance)

ANOVA can be useful for determining influence of any given input parameter from a series of experimental results by design of experiments for machining process and it can be used to interpret experimental data. Analysis of variance (ANOVA) is a subordinated procedures and collection of statistical models. The detected variance in a particular variable is partitioned into components attributable to unlike sources of variation. ANOVA offers a statistical test of whether or not the means of several groups are all equal, and therefore simplifiestest to more than two groups and is used in the analysis of proportionaltrials, those in which only the alteration in results is of interest. The statistical consequence of the experiment is determined by a proportion of two variances. This proportion is impartial of numerousfeasiblerevisions to the experimental remarks. Adding a constant to all interpretations does not modify significance. Multiplying all interpretations by a constant does not alter significance. So ANOVA statistical significance results are independent of invariablepreference and scramblinglapses as well as the units used in transferring observations.

3.2 Mathematical model

Response-1 Metal Removal Rate
ANOVA for selected factorial model

International Journal of Innovative Research in Science, Engineering and Technology

(An ISO 3297: 2007 Certified Organization)

Vol. 4, Issue 6, June 2015

Table:5 Analysis of variance table [Partial sum of squares - Type III]

| SOURCE | Sum of Squares | DF | MEAN SQUARE | F VALUE | p- value PROB>F | |
|-----------|----------------|----|-------------|----------|-----------------|-------------|
| Model | 7061.58 | 10 | 706.158 | 232.1361 | < 0.0001 | Significant |
| A-SPEED | 1232.01 | 1 | 1232.01 | 405 | < 0.0001 | |
| B-FEED | 2631.69 | 1 | 2631.69 | 865.1183 | < 0.0001 | |
| C-DOC | 2631.69 | 1 | 2631.69 | 865.1183 | < 0.0001 | |
| D-ANGLE | 0 | 1 | 0 | 0 | 1.0000 | |
| AB | 136.89 | 1 | 136.89 | 45 | 0.0011 | |
| AC | 136.89 | 1 | 136.89 | 45 | 0.0011 | |
| AD | 0 | 1 | 0 | 0 | 1.0000 | |
| BC | 292.41 | 1 | 292.41 | 96.12426 | 0.0002 | |
| BD | 0 | 1 | 0 | 0 | 1.0000 | |
| CD | 0 | 1 | 0 | 0 | 1.0000 | |
| Residual | 15.21 | 5 | 3.042 | | | |
| Cor Total | 7076.79 | 15 | | | | |

The Model F-value of 232.14 implies the model is Significant. There is Only a 0.01% chance that a "Model F-Value" this large could occur due to noise.

Values of "Prob >F" less than 0.0500 indicate model terms are Significant.

In this case A, B, C, AB, AC, BC are Significant model terms.

Values greater than 0.1000 indicate the model terms are not significant.

If there are many insignificant model terms (not counting those required to support hierarchy), model reduction may improve your model.

Table:6 Anova values for MRR

| | | | |
|-----------|----------|----------------|----------|
| Std. Dev. | 1.744133 | R-Squared | 0.997851 |
| Mean | 38.475 | Adj R-Squared | 0.993552 |
| C.V. % | 4.533159 | Pred R-Squared | 0.977991 |
| PRESS | 155.7504 | Adeq Precision | 47.60888 |

The "Pred R-Squared" of 0.9780 is in reasonable agreement with the "Adj R-Squared" of 0.9936.

"Adeq Precision" measures the signal to noise ratio. A ratio greater than 4 is desirable.

Your ratio of 47.609 indicates an adequate signal. This model can be used to navigate the design space.

Final Equation in Terms of Coded Factors:

$$\begin{aligned}
 \text{MRR} &= \\
 &38.475 \\
 &+ 8.775 * A \\
 &+ 12.825 * B \\
 &+ 12.825 * C \\
 &+ 0 * D \\
 &+ 2.925 * A * B \\
 &+ 2.925 * A * C \\
 &+ 0 * A * D
 \end{aligned}$$

International Journal of Innovative Research in Science, Engineering and Technology

(An ISO 3297: 2007 Certified Organization)

Vol. 4, Issue 6, June 2015

4.275 * B * C
0 * B * D
0 * C * D

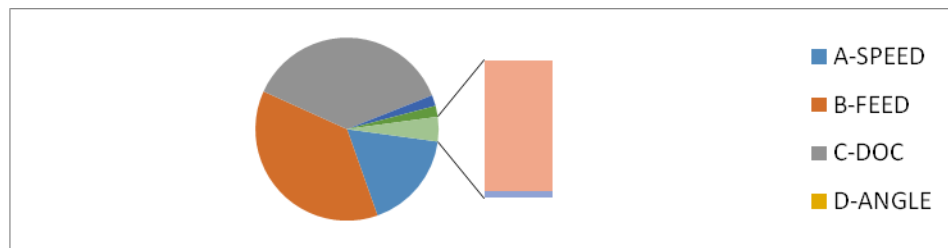

Fig: 4.1Pie chart for metal removal rate

Response-2 Tool Wear
ANOVA for selected factorial model

Table:7 Analysis of variance table [Partial sum of squares - Type III]

| SourceModel | Sum ofSquares | df | MeanSquare | FValue | p-valueProb > F | |
|-------------|---------------|----|------------|----------|-----------------|-------------|
| | 0.011785 | 7 | 0.001684 | 4.510292 | 0.0253 | Significant |
| A-SPEED | 0.00191 | 1 | 0.00191 | 5.115921 | 0.0536 | |
| B-FEED | 0.000103 | 1 | 0.000103 | 0.27599 | 0.6136 | |
| C-DOC | 0.005013 | 1 | 0.005013 | 13.4285 | 0.0064 | |
| AB | 0.000872 | 1 | 0.000873 | 2.339246 | 0.1647 | |
| AC | 0.001136 | 1 | 0.001136 | 3.042431 | 0.1193 | |
| BC | 0.001612 | 1 | 0.001612 | 4.318491 | 0.0713 | |
| CD | 0.001139 | 1 | 0.001139 | 3.051466 | 0.1188 | |
| Residual | 0.002986 | 8 | 0.000373 | | | |
| Cor Total | 0.014772 | 15 | | | | |

The Model F-value of 4.51 implies the model is significant. There is only a 2.53% chance that a "Model F-Value" this large could occur due to noise.

Values of "Prob > F" less than 0.0500 indicate model terms are significant.

In this case C are significant model terms.

Values greater than 0.1000 indicate the model terms are not significant.

If there are many insignificant model terms (not counting those required to support hierarchy), model reduction may improve your model.

Table:8 Anova values for Tool Wear

| | | | |
|-----------|----------|----------------|----------|
| Std. Dev. | 0.019321 | R-Squared | 0.797837 |
| Mean | 0.1098 | Adj R-Squared | 0.620944 |
| C.V. % | 17.59613 | Pred R-Squared | 0.191348 |
| PRESS | 0.011945 | Adeq Precision | 6.529205 |

International Journal of Innovative Research in Science, Engineering and Technology

(An ISO 3297: 2007 Certified Organization)

Vol. 4, Issue 6, June 2015

The "Pred R-Squared" of 0.1913 is not as close to the "Adj R-Squared" of 0.6209 as one might normally expect. This may indicate a large block effect or a possible problem with your model and/or data. Things to consider are model reduction, response transformation, outliers, etc.

"Adeq Precision" measures the signal to noise ratio. A ratio greater than 4 is desirable. Your ratio of 6.529 indicates an adequate signal. This model can be used to navigate the design space.

Final Equation in Terms of Coded Factors:

$$\begin{aligned} \text{Tool Wear} = & 0.1098 \\ & + 0.010925 * A \\ & + 0.002538 * B \\ & - 0.0177 * C \\ & + 0.007388 * A * B \\ & + 0.008425 * A * C \\ & + 0.010038 * B * C \\ & - 0.00844 * C * D \end{aligned}$$

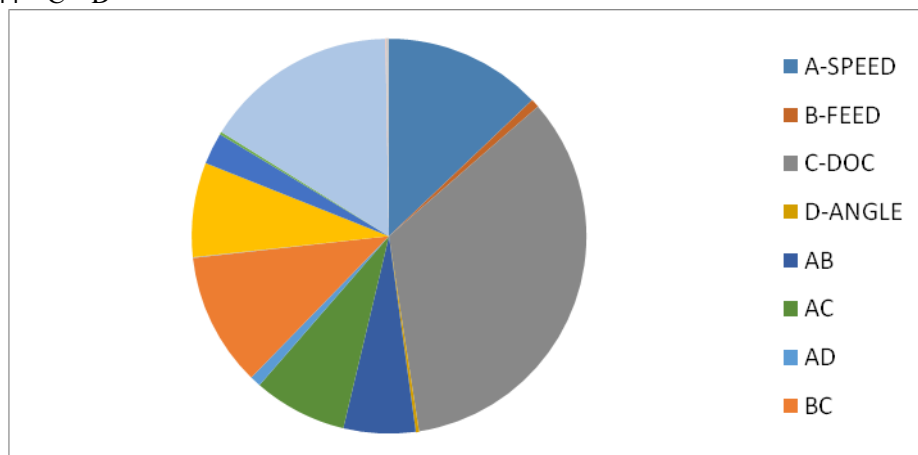

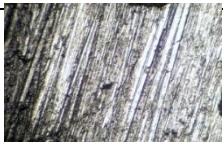

Fig: 4.2 Pie Chart for Tool Wear

3.3 Micro structure & Hardness for 2 level half factorial

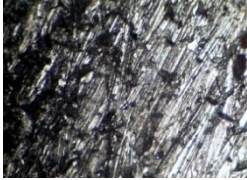

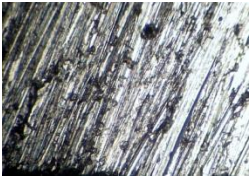



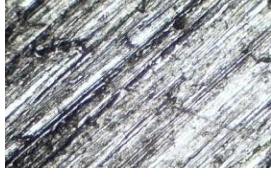

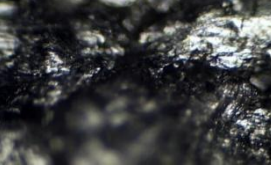

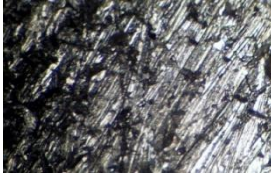

Table: 9Micro structure & Hardness for 2 level half factorial

| Run | Billet | Speed | Feed | DOC | Angle | Hardness (HV) | Micro Structure |
|-----|---|-------|------|-----|-------|---------------|---|
| 1 |  | 350 | 0.4 | 0.6 | 70 | 155 |  |

International Journal of Innovative Research in Science, Engineering and Technology

(An ISO 3297: 2007 Certified Organization)

Vol. 4, Issue 6, June 2015

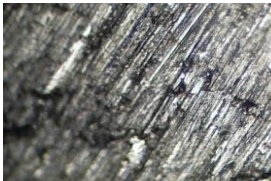
| | | | | | | | |
|---|---|-----|-----|-----|----|-----|---|
| 2 |  | 350 | 0.2 | 0.3 | 70 | 141 |  |
| 3 |  | 220 | 0.4 | 0.3 | 70 | 167 |  |
| 4 |  | 350 | 0.2 | 0.6 | 45 | 151 |  |
| 5 |  | 220 | 0.2 | 0.3 | 45 | 136 |  |
| 6 |  | 220 | 0.4 | 0.6 | 45 | 121 |  |
| 7 |  | 350 | 0.4 | 0.3 | 45 | 159 |  |
| 8 |  | 220 | 0.2 | 0.6 | 70 | 162 |  |

IV. GRAPHS FOR MAX CHIP LENGTH, MRR , TOOLWEAR & HARDNESS

Graph-1: Run Vs Max Chip Length Graph-2 : Run Vs Metal Removal Rate

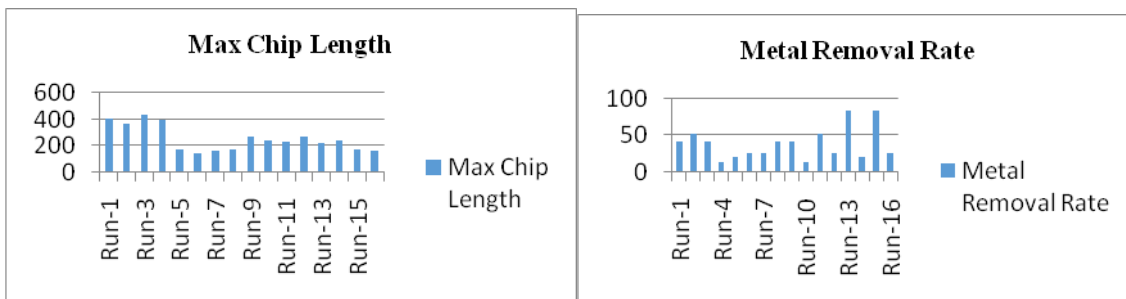

Graph-3: Run Vs Tool Wear

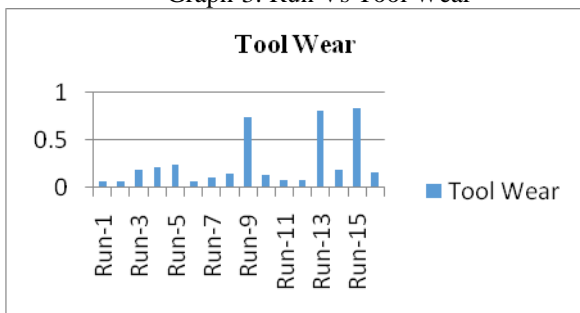

Graph-4: Billet Vs Hardness

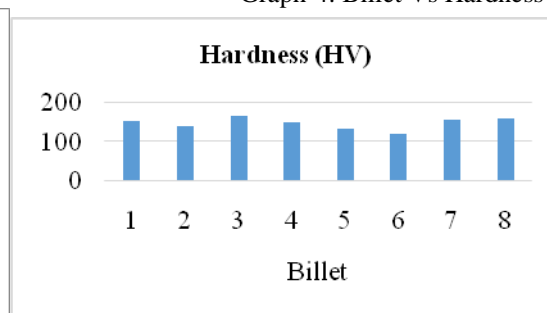

V. CONCLUSION

In this experimental that the factorial design work is to find the relationship between input parameter & output parameter was successfully carried out and the relationship between input & output was shown in the mathematical model. That the significance of the model was analysed by the Anova. The model also significant from this model. The output parameter of Metal Removal Rate is most significantly affected by DOC. Which is compared to the speed & feed. In this experiment maximum chip length, metal removal rate, tool wear is is to be calculated for the input parameters of full factorial & the micro structure, hardness also to be identified for the output parameters of half factorial.

REFERENCES

1. Abhang L.B., Hameedullah M.: Chip-Tool Interface Temperature Prediction Model for Turning Process, International Journal of Engineering Science and Technology, Vol 2(4), 2010., pp. 382-393.
2. Palanikumar, L. Karunamoorthy, R. Krathikeyan, Assessment of factors influencing surface roughness on the machining of glass –reinforced polymer composites, Journal of Materials and Design, 27 (2006) 862-871.
3. Xue Ping, C. Richard Liu, Zhenqiang Yao, Experimental study and evaluation methodology on hard surface integrity, International Journal Advanced Manufacturing Technology, ODI 10.1007/s00170-006-0576-6.
4. T. Tamizharasan, T. Selvaraj, A. Noorul Hag, Analysis of tool wear and surface finish in hard turning, International Journal of Advanced Manufacturing Technology (2005), DOI 10/1007 /s 00170-004-2411-1.
5. Zahari Taha, H.K.Lelana, Hideki Aoyama, "Effect of Insert Geometry on Surface Roughness In the Turning Process of AISI D2" The 11th Asia Pacific Industrial Engineering and Management System Conference.
6. Suleyman Neseli , Suleyman Yaldız , Erol Turkes, "Optimization of tool geometry parameters for turning operations based on the response surface methodology" Measurement 44 (2011) 580–587.
7. Ilhan Asilturk , Harun Akkus, "Determining the effect of cutting parameters on surface roughness in hard turning using the Taguchi method" Measurement 44(2011) 1697–1704.

International Journal of Innovative Research in Science, Engineering and Technology

(An ISO 3297: 2007 Certified Organization)

Vol. 4, Issue 6, June 2015

8. H. K. Davea, L. S. Patelb and H. K. Ravala, "Effect of machining conditions on MRR and surface roughness during CNC Turning of different Materials Using TiN Coated Cutting Tools – A Taguchi approach" International Journal of Industrial Engineering Computations.
9. Fang N., Srinivasa Pai, P. and Mosquea, S. "Effect of tool edge wear on the cutting forces and vibrations in high-speed finish machining of Inconel 718: an experimental study and wavelet transform analysis", International Journal of Advanced Manufacturing Technology, 2703-6, 2007.
10. John D. Kechagias, Christos K. Ziogas, Menelaos K. Pappas and Ioannis E. Ntziatzias, "Parameter optimization during Finish End Milling of Al Alloy 5083 using Robust Design", Proceedings of the World Congress on Engineering, Vol. I, 2011.
11. Kadirgama, K. and Noor, M.M. "Optimization of Surface Roughness in End Milling on Mould Aluminium Alloys (AA6061-T6) Using Response Surface Method and Radian Basis Function Network", Jordan Journal of Mechanical and Industrial Engineering, Vol. 2, No. 4, pp. 209-214, 2008.
12. Lin, T.-R. "Optimisation Technique for Face Milling Stainless Steel with Multiple Performance Characteristics", International Journal of Advanced Manufacturing Technology, Springer-Verlag, Vol. 19, pp. 330-335, 2002.
13. Mike S. Lou, Joseph C. Chen and Caleb, M. "Surface roughness prediction technique for CNC end Milling", Journal of Industrial Technology, Vol. 15, 1999.
14. Sasikumar R and Arunachalam R.M. 2009. Synthesis of nanostructured aluminum matrix composite (AMC) through machining, Materials Letter, Vol. 63, pp.2426 -2428.
15. Shankar M.R., Verma R., Rao B.C., Chandrasekar S., Compton W.D., King A.H. 2005. Characteristics of aluminum 6061-T6 deformed to large plastic strains by machining, Materials Science and Engineering, Vol. A 410-411, No. 15, pp.364-368.
16. N. S. K. Reddy, S. Kwang-Sup, and M. Yang, "Experimental study of surface integrity during end milling of Al/SiC particulate metal- matrix composites," J. Mater. Process. Tech., vol. 201, 2008, pp. 574-579.
17. A. R. Alao, and M. Konneh, "A response surface methodology based approach to machining processes: modelling and quality of the models," Int. J. Experimental Design and Process Optimisation, vol. 1 no. 2/3, 2009, pp. 240-261
18. M. Kovacic, J. Balic, Evolutionary programming of a CNC cutting machine, Int. J. Adv. Manufact. Technol. (2002)
19. S. Chao-Ton, C. Mu-Chen, Computer-aided optimization of multi-pass turning operations for continuous forms on CNC lathes, IIE Trans. 1999
20. W S Lin, B.Y. Lee, C. L. Wu, Modeling the surface roughness and cutting force for turning, Journal of Materials Processing Technology, 2001.
21. Q. Meng, JA Arsecularatne, P. Mathew. Calculation of optimum cutting conditions for turning operations using a machining theory, International Journal of Machine Tools and Manufacture, 2000
22. Rosochowski A., Olejnik L., Numerical and physical modelling of plastic deformation in 2-turn equal channel angular extrusion, Journal of Materials Processing Technology 125-126, p.p. 309-316, 2002
23. Iwahashi Y., Horita Z., Nemoto M. and Langdon T.: The process of grain refinement in equal channel angular pressing, Acta mater. 46/9, p.p. 3317-3331, 1998.
24. Valiev R.Z., Islamgaliev R.K., Alexandrov I.V.: Bulk nanostructured materials from severe plastic deformation, Progress in Materials Science 45, p.p. 103-189, 2000.