

# AGC of A Gas-Thermal System with ESD Units

R.Senthilkumar , PiyushRai, Megha Katiyar

Assistant Professor (O.G), Department of EEE, SRM University, Kattankulathur, Kancheepuram, Tamil Nadu, India

B.Tech, Department of EEE, SRM University, Kattankulathur, Kancheepuram, Tamil Nadu, India

B.Tech, Department of EEE, SRM University, Kattankulathur, Kancheepuram, Tamil Nadu, India

**ABSTRACT:** In this paper, automatic generation control (AGC) of two area interconnected power system having diverse sources of power generation is studied. All the power generation units from different sources are equipped with speed governors. A continuous time transfer function model of the system for studying dynamic response for small load disturbances is presented. In general the proportional -integral-derivative (PID) are used but in this work we have the fuzzy logic automatic generation as control scheme applied to the sources and power generation from the source is allowed to operate at its scheduled level with only speed governor control. Whereas the effect of the external energy storage devices that may help the AGC to work in more optimal way so the part of the frequency deviation is rectified with a very quick time response.

**KEYWORDS:** PID Controller, CES, SMES, Fuzzy Controller

## I. INTRODUCTION

Power systems consist of control areas representing a coherent group of generators i.e. generators which swing in unison characterized by equal frequency deviations. In addition to their own generations and to eliminate mismatch between generation and demand these control areas are interconnected through tie-lines for providing contractual exchange of power under normal operating conditions. One of the control problems in

power system operation is to maintain the frequency and power interchange between the areas at their rated values.

Many articles are reported [2]-[6] demonstrating the use of SMES unit for the improvement of transient stability. SMES is controlled through conventional controllers in most of these works. The power system stability is mainly dependent on the appropriate control strategy of SMES. Though many SMES control strategies [2]-[6] are proposed in the literature, the real problem is the determination of the best or optimal switching strategies.

In previous research, frequency deviation of one area has been used as a control signal of SSSC [3, 4]. In this scheme, SSSC is not able to compensate for load changes in both areas on both sides of the SSSC. For this reason, in [3,4], it has been assumed that load changes occur in one of the areas on both sides of SSSC. In this paper, a new scheme for the control signal of SSSC is presented. By using the new control scheme, SSSC becomes able to compensate for load changes in both areas on both sides of SSSC. Supplementary controllers are designed to regulate the area control errors to zero effectively. Even in the case of small load disturbances and with the optimized gain for the supplementary controllers the power frequency and the tie-line power deviations persist for a long duration. In these situations, the governor system may no longer be able to absorb the frequency fluctuations due to its slow response.

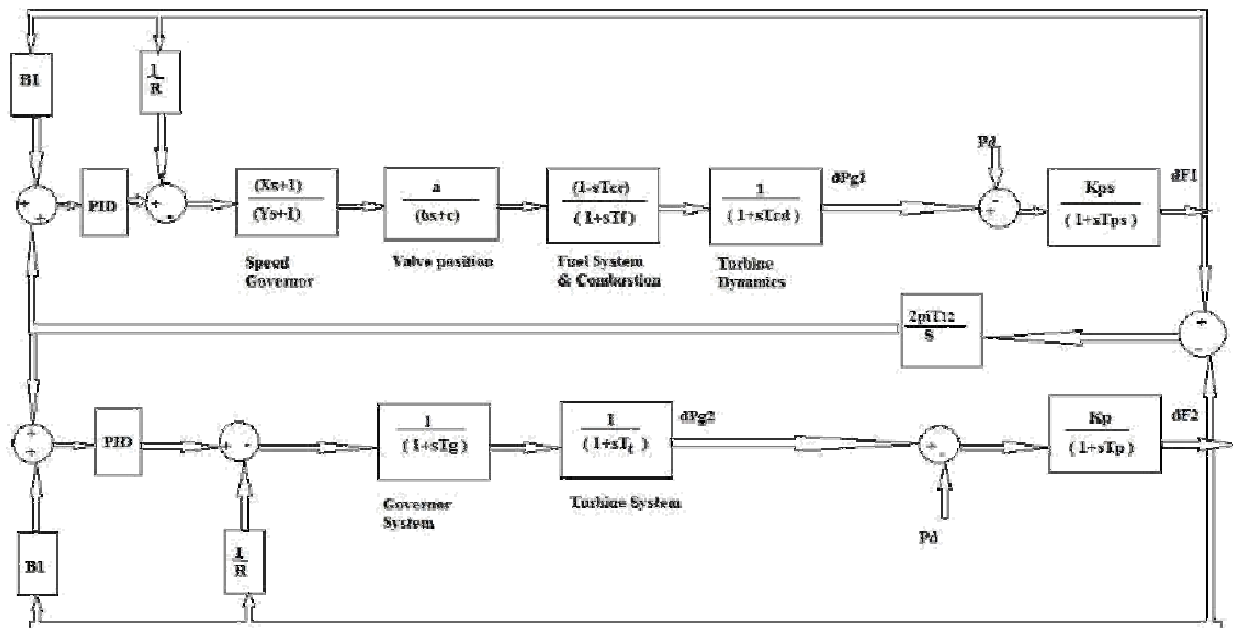

Fig 1: Two Area Gas-Thermal System

## II. GAS-THERMAL POWER SYSTEM MODEL

Electric power systems are complex, nonlinear dynamic system. The load frequency controller controls the control valves associated with High Pressure (HP) turbine at very small load variations. The model of a two-area power system suitable for a digital simulation of AGC is developed for the analysis as shown in Fig. 1. Two areas are connected by a weak tie-line. When there is sudden rise in power demand in one area, the stored energy is almost immediately released by the SMES and CES through its power conversion system. As the governor control mechanism starts working to set the power system to the new equilibrium condition, the SMES coil stores energy back to its nominal level whereas a similar action happens with the CES model. This action also happens when there is a sudden decrease in load demand.

## III. CAPACITIVE ENERGY STORAGE

Super capacitors, also known as electrical double-layer capacitor, ultra capacitor, are new energy storage devices that close the gap between aluminium electrolytic capacitors and batteries in terms of power and energy density [2]. Its capacity ranges from several farads to tens of thousands farads and its power density is 10 times more than battery's. The storage capacity of super capacitor is higher than electrolytic capacitor, and it has wide working temperature range, rapid charging and discharging, long cycle life, no pollution and emission and so on[3-5]. This makes them ideal for all applications requiring high peak power discharge for a few milliseconds up to several minutes' conditions.

The energy storage system plays an important role for improving the power quality of the micro grid. Through the inverter control unit, it can adjust the super capacitor energy storage system to provide active and reactive power for users, so as to enhance the power quality [8]. As the super capacitor can quickly absorb and release electric energy with high power, it is very suitable to solve some of the transient issues in the system, such as instantaneous outage caused by the system failures, a sudden swell in voltage, and the voltage sag and so on. At this time, the super capacitor can be used to absorb or compensate

## International Journal of Innovative Research in Science, Engineering and Technology

(An ISO 3297: 2007 Certified Organization)

Vol. 4, Issue 6, June 2015

the power shortage in order to stabilize and smooth the voltage fluctuations. Similar is the action during sudden release of loads. The capacitor is charged immediately towards its full value, thus absorbing some portion of the excess energy in the system and as the system returns to its steady state, the absorbed excess energy is released and the capacitor voltage attains its normal value.

$$\Delta P_{CES} = \Delta I_{d0} \times (E_{d0} + \Delta E_{di}) ; i = 1, 2$$

$$\text{Where } \Delta E_{di} = \frac{\Delta I_{di}}{C_i s + \frac{1}{R_i}} ; i = 1, 2.$$

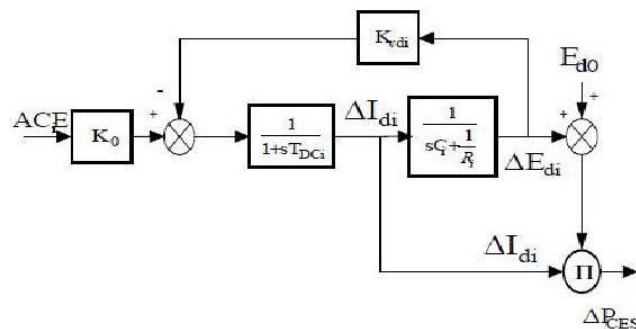

Figure 2. CES Unit: Block diagram representation with formulation

### IV. SUPER MAGNETIC ENERGY STORAGE

During the automatic generation control operation of an interconnected power system including SMES units, the dc voltage across the superconducting inductor is continuously controlled depending on the sensed ACE signal. Fig. 3 shows the block diagram representation of the simple control scheme for SMES [22], where  $I_{sm}$ ,  $V_{sm}$  and  $P_{sm}$  are SMES current, voltage and power respectively. ACE is used as the input to the SMES controller. Since inductor current is required to be restored to its rated value very quickly after a system disturbance so that the SMES unit becomes ready to respond to the next load disturbance immediately, therefore, inductor current deviation is sensed and fed back as negative signal in the SMES control loop to achieve quick restoration of current and SMES energy levels. Dynamic performance of the power system depends on the values of SMES controller gain  $K_p$  and integral controller gain  $K_i$ . The optimal values of  $K_p$  for the system studied were chosen by hit and trial method. It was observed that the higher values of  $K_p$  decrease the overshoot but increase the settling time of the system and lower values of  $K_p$  on the other hand increase the overshoot but decrease the settling time of the system. So an optimal value of  $K_p$  was chosen with respect to the integral gain  $K_i$ , optimal value of which is obtained through minimization of the performance index.

# International Journal of Innovative Research in Science, Engineering and Technology

(An ISO 3297: 2007 Certified Organization)

Vol. 4, Issue 6, June 2015

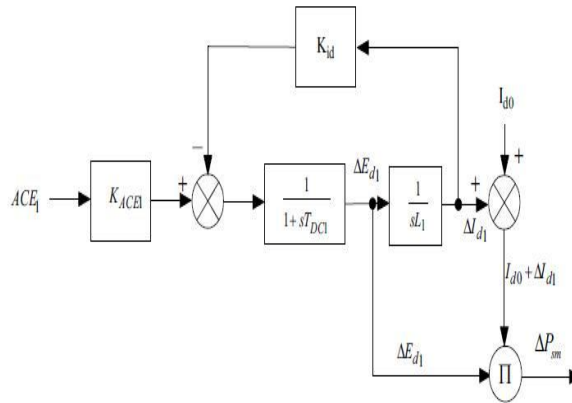

Fig.3: SMES Block diagram

## V. DYNAMIC MODEL OF SSSC

The linearized model of a two area interconnected system [3] including the dynamic of SSSC is shown in Fig. 4, where the dynamics of governor systems in both areas are eliminated. Power output of SSSC ( $P_{SSC}$ ), therefore, flows into both areas with different signs (+, -), simultaneously. In the presence of SSSC between areas 1 and 2, active power flow deviation between areas 1 and 2 can be expressed as follow [3, 6]:

$$P_{12} = P_{tie-12} + P_{SSSC}$$

Where  $\Delta P_{tie-12}$  is tie-line power flow deviation between areas 1 and 2 without SSSC, and  $\Delta P_{SSSC}$  is active power flow deviation between areas 1 and 2 due to SSSC.  $\Delta P_{SSSC}$  flows into both areas 1 and 2 with different signs (+ and -) dynamically [3, 6].

Linearized model of SSSC and its active power controller are shown in Fig. 4. As shown in Fig. 4, SSSC is a MIMO system. Active power controller of SSSC, i.e.  $K_C(s)$  consists of a lead/lag compensator, a High Pass Filter (HPF) and a controller gain [3, 4]. Transfer function of active power controller of SSSC can be expressed as follow:

$$K_C(s) = K_{SSSC} \frac{T_w}{1+T_w} \frac{1+T_1s}{1+T_2s} \frac{1+T_3s}{1+T_4s}$$

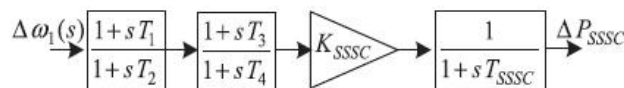

Fig 4. SSSC Block Diagram

## VI. THE PROPOSED FUZZY GAIN SCHEDULED PID (FGSPID) CONTROLLER

The general practice in the design of a LFC is to utilize a PI and PID controllers. A typical conventional PID control system this gives adequate system response considering the stability requirements and the performance of its regulating units. In this case the response of the PI and PID controller is not satisfactory enough and large oscillations may occur in the system [8-9]. For that reason, a fuzzy PID controller is designed and implemented in this study. The AGC based on FLC is proposed in this study. One of its main advantages is that controller parameters can be changed very quickly by the system dynamics because no parameter estimation is required in designing controller for nonlinear system.

Besides being an effective technique to compensate for non-linear and other predictable variations in the system dynamics, it is also easier to implement. The gain scheduling in this study is done based on the frequency deviation step response of the system for different values of  $K_p$ ,  $K_i$ ,  $K_d$  with 0.01 p.u.MW step load change in area-1. As a higher value of  $K_i$  results in reduction of maximum deviation of the system frequency but the system oscillates for little longer times, whereas lower values of  $K_i$  yield comparatively higher maximum frequency deviation at the beginning but provide effective damping in the later cycles.

In Figure , NB, NS, Z, PS, and PB are the linguistic terms that represent negative big, negative small, zero, positive small, and positive big respectively. The bisector of area method was used for defuzzification. The control rules for the proposed controller are very straightforward and have been derived from the viewpoint of practical system operation using trial and error methods. The fuzzy rules, as used in our study, for the FGSPID controller, are given in Table I. In the present study, dynamic response was further investigated with modified ACE as the input signal to the FGSPID controller.

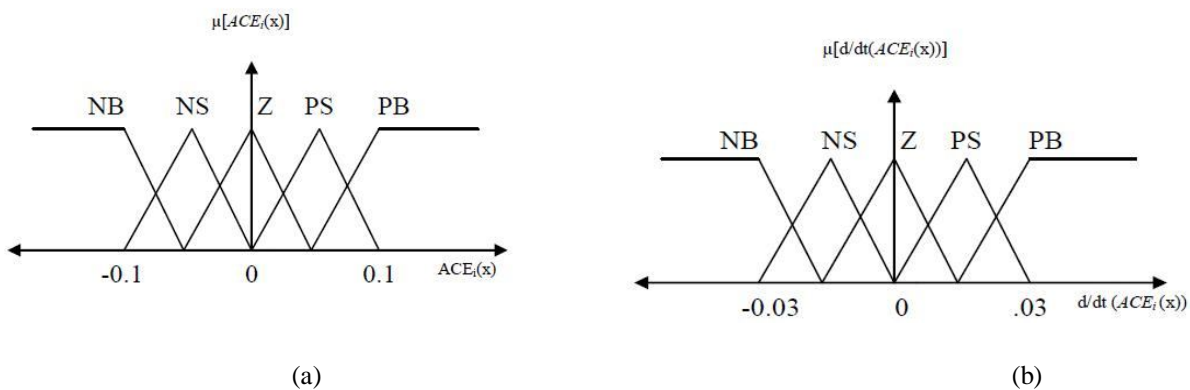

$\Delta ACE / ACE$	NB	NS	Z	PS	PB
NB	PS	NB	NB	NS	NS
NS	NS	NS	NB	NS	NS
Z	NB	NS	Z	NS	PB
PS	NB	Z	NS	PB	NB
PB	Z	NS	NS	NB	PB

(c)

Fig 5. (a)Input 1,(b) Input 2 ,(c) Fuzzy Rules

# International Journal of Innovative Research in Science, Engineering and Technology

(An ISO 3297: 2007 Certified Organization)

Vol. 4, Issue 6, June 2015

## VII. SIMULATION RESULTS

In this control scheme i.e.;(PID + SSSC WITH VARIOUS EDS) that determines the various conditions for handling through the frequency deviation.

The following paper mainly focuses on the Gas aspect, As per the previous years' work we had only the installation of the particular systematic Energy storage devices were installed but in this work a clear study after the implementation of the particular SSSC i.e.; basically a fact device which plays a role of Frequency stabilization

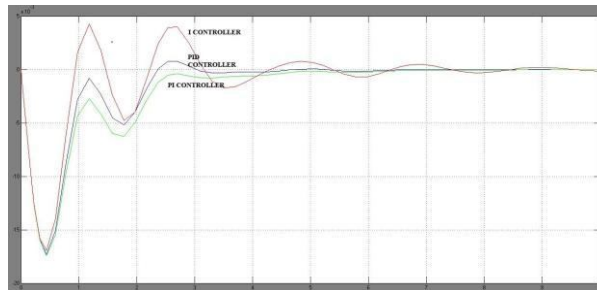

Fig 6: Frequency deviation at area1 at conventional methods.

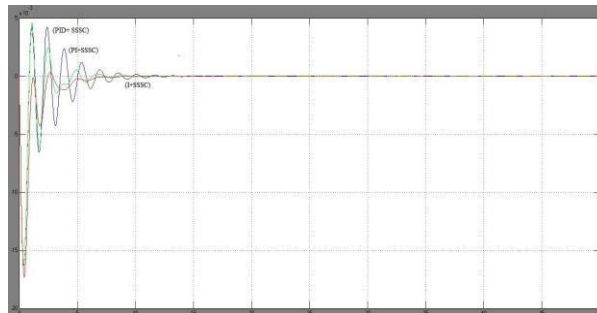

Fig 7: Frequency deviation at area1 with SSSC implementation.

As per the above graphical representation i.e.; Fig 6.the conventional methodology is followed through to determine values of the best control strategy. The tabulation shows the particular rise time which states the main theme of stabilization.

The part of the comparative study of the conventional control method after the implementation of the FACTS device shown an improved strategy from weakens deviation. This is followed with the EDS implementation that helps out in reaching out constant valuation in a quick manner which 25% faster than the conventional controlled.

## International Journal of Innovative Research in Science, Engineering and Technology

(An ISO 3297: 2007 Certified Organization)

Vol. 4, Issue 6, June 2015

GAS POWER PLANT	Settling Time	Rise Time	Peak	Over shoot
I Cont	4.14	0.599	1.05	5.12
PI Cont	6.03	2.83	1	0
PID Cont	4.7	1.94	0.999	0
I + CES	20.8	1.68	1.01	1.07
PI + CES	4.59	0.287	1.29	29.5
PID+CES	0.196	0.022	1.12	12.4
I+SMES	4.92	0.293	1.79	78.8
PI+SME S	0.9	0.112	1.06	5.87
PID+ SMES	0.369	0.011	1.09	9.23
I+SSSC	1.38	5.7	2.36	1.02
PI+SSSC	0.597	5.14	6.19	1.06
PID+ SSSC	0.575	5.61	8.35	1.08
ICont+CES+SSSC	1.17	21.6	11.3	1.11
PICont+CES+SSSC	0.304	74.6	68.3	1.68
PIDCont+CES+SSSC	0.0045	0.0657	12.6	1.13
I+SMES+SSSC	2.48	16.1	1.47	1.01
PI+SME S+SSSC	0.0775	0.867	13.9	1.14
PIDCont+SMES+SSSC	0.0443	0.706	12.2	1.12



## International Journal of Innovative Research in Science, Engineering and Technology

(An ISO 3297: 2007 Certified Organization)

Vol. 4, Issue 6, June 2015

As per the result found out determine the state that which has the criteria varying in each and every data whereas the part of I controller as the best output which has arise time of 4.14 secs.

Well then entering in to the installation of the EDS give the implementation value of the particular PID where Proportionality and the derivative control strategy is also required.

PID Control with CES having a Rise time 0.196secs whereas after adding up the SSSC 0.00459secs. But while implementation of only SSSC the time taken 0.369secs which states that CES is one of the cheapest type of implementing the particular format.

Well the part SMES states that it's not faster i.e.; 0.575secs which is better than the conventional but slower than CES devised system. Whereas the SSSC when added it takes only 0.0443secs which states that the system is much faster than the previous stimulations.

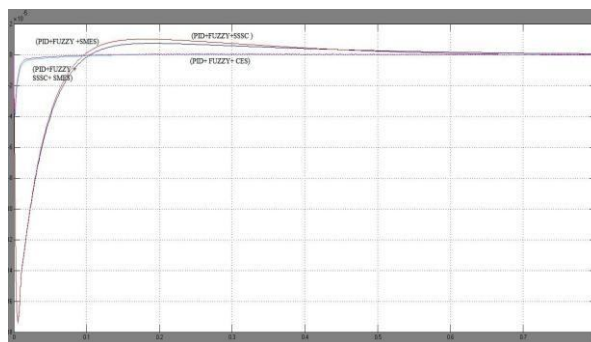

Fig 8: Frequency deviation at area1 with Fuzzy logic.

The particular fuzzy tabulation states that the FPID is one of the best methods of improving the particular stabilization in more optimal way. As per our Research we found out that the PID controller where the best in case of including the FACTS devices without any Energy storage devices. So we took the best conventional output to implement the fuzzy logic control scheme.

As the FPID logic controller gave an output which were very much satisfying with one of the most quick and optimal way of carrying out the Frequency stabilization. The similar studies are carried out in Thermal plant whereas we have focused more on the Gas since it is a new form of implementation these control strategies.

GAS POWER PLANT	Settling Time	Rise Time	Peak	Overshoot
I+ Fuzzy	2.06	4.87	0	0.999
PID+Fuzzy+CES	0.004	0.35	14	1.14
PID+Fuzzy+SMES	0.00098	0.118	18.7	1.18



# International Journal of Innovative Research in Science, Engineering and Technology

(An ISO 3297: 2007 Certified Organization)

Vol. 4, Issue 6, June 2015

I+Fuzzy+SSSC	1.34	2.36	1.22	1.01
PID+Fuzzy+SSSC+CES	0.00403	2.93	14.4	1.14
PID+Fuzzy+SSSC+SMES	0.00082	0.982	1.82	1.18

Thermal POWER PLANT	Settling Time	Rise Time	Peak	overshoot
I+Fuzzy	2.86	5.69	0	0.999
PID+Fuzzy+CES	0.0536	0.654	17.1	1.17
PID+Fuzzy+SMES	0.0359	0.5844	13.2	1.13
I+Fuzzy+SSSC	12.4	22.4	0	0.999
PID+Fuzzy+SSSC+CES	0.0539	0.67	17.2	1.17
PID+Fuzzy+SSSC+SMES	0.0862	0.982	1.29	1.13

## VII. CONCLUSION

The simulation studies have been carried out on a two-area power system to investigate the impact of the proposed intelligently controlled AGC including FPID logic with SSC and EDS units on the power system dynamic performance. Results obtained with modified ACE, a new proposition, indicate that the scheme is effective and helps improve the dynamic response. Results of the proposed FGSPID controller were compared against the conventional PID controller implemented on the same system and for same operation cases. Finally results prove that the proposed FPID scheme with the FACTS and Energy storage device is very powerful in reducing the frequency deviations under a variety of load perturbations.

## REFERENCES

- [1] Mahalanabis, A.K., Kothari, D.P., and Ahson, S.I.: 'Computer aided power system analysis and control', Tata McGraw-Hill, 1988
- [2] Kundur, P. : 'Power system stability and control', McGraw-Hill, Inc., 1994.
- [3] N.N. Bengiamin, M.Egg, Mem. I.E.E.E., and W.C. Chan, M.Sc, Ph.D., Sen. Mem. I.E.E.E., "Multilevel load-frequency control of interconnected power systems", PROC. IEE, Generation, Transmission and Distribution, Vol. 125, No. 6, pp.521-526. JUNE 1978.
- [4] O. I. Elgerd, Electric Energy Systems Theory: An Introduction. New York: McGraw-Hill, 1982.
- [5] Nanda J, KaviBL.: "Automatic Generation Control of Interconnected Power System", IEE Proceedings, Generation, Transmission and Distribution, 1988; No.125 (5): pp.385-390.

# International Journal of Innovative Research in Science, Engineering and Technology

*(An ISO 3297: 2007 Certified Organization)*

**Vol. 4, Issue 6, June 2015**

- [6] Sivaramakrishna AY et. Al., "Design of variable structure load frequency controller using pole assignment technique", Int. Journal of Control, 1984; 40(3):487-98
- [7] Das D, Kothari ML, Kothari DP, Nanda J, "Variable structure control strategy to automatic generation control of interconnected reheat thermal systems", IEE Proc. Control Theory Applications. 1991; 138(6):579-85. Tacker EC, Lee CC, Reddoch TW, Tan TO, Julich PM, "Optimal control of interconnected electric energy systems: a new formulation", Proc IEEE, 1972; 60(10): 1239-41.
- [8] Yamashita K, Taniguchi T, "Optimal design for load frequency control", Int. J. Elect Power Energy Syst 1986; 8(2): 93-100.
- [9] Wang Y, Zhou R, Wen C, "Robust load frequency controller design for power systems", Proc. IEE Gen Trans, Distri 1993; 140(1):111-6.
- [10] Stankovi AM, Tadmor G, Sakharuk, TA, "On robust control analysis and design for load frequency regulation", IEEE Trans Power Syst 1998; 13(2): 449-54.
- [11] Ibraheem, Prabhat Kumar, and Dwarka P. Kothari, "Recent philosophies of automatic generation control strategies in power systems", Ieee Transactions On Power Systems, Vol. 20, No. 1, February , 2005, 20(1): 346-57.
- [12] C. S. Indulkar and B. Raj, "Application of fuzzy controller to automatic generation control," Elect. Machines Power Syst., vol. 23, no.2, pp. 209-220, Mar.-Apr. 1995.
- [13] Chang C.S., Fu W. "Area load-frequency control using fuzzy gain scheduling of PI controllers," Electric Power system Research, Vol.42, 1997, pp. 145-52.