

Performance Improvement of Production Line A Case Study in Small Scale Industry

Santosh Kulkarni ¹, G.R.Naik ²P.G. Student, Department of Production Engineering, K.I.T's Engineering College, Kolhapur, Maharashtra, India¹Associate Professor, Department of Production Engineering, K.I.T's Engineering College, Kolhapur, Maharashtra,
India²

ABSTRACT: Performance improvement can be done on four major parameters. First is resource input requirement, second throughput requirement or process efficiency, third is output requirement which known by cost, quality and functionality and fourth is outcome requirement. There are several methods and tools to improve the performance of production line but backbone of research project is queuing theory. It is the mathematical studies of waiting line or quest. There are several queuing models are present like single server multiphase, multi-server multiphase models. In most of the studies two or more stations subsystems are analysed by G/G/G/1 for performance improvement. This paper describes a case study which is under observation, by preliminary analysis several issues are came out which is hampering the performance of production line so to minimise those issues enhancement in performance of production line is a need.

I. Introduction

Performance improvement is measuring the output of a particular business process then modifying the process or procedure to increase the output, increase efficiency, or increase the effectiveness of the process or procedure. Performance improvement can be applied to either individual performance such as organizational performance such as a commercial business.[3]

Productivity growth is important to the firm; because it means that it can meet its (perhaps growing) obligations to workers, shareholders and governments and still remain even improve its competitiveness in the market place. The way to promote growth in output is bring additional inputs into production adding more inputs will not increase the income earned per unit of input. In fact, it is likely to mean lower average wages and lower rates of profit. But, when there is productivity growth, even the existing commitment of resources generates more output and income. Income generated per unit of input increases. Additional resources are also attracted into production and can be profitably employed [5].

Queuing theory is the technique which is widely used in waiting line, to optimise decision and to reduce waiting time for customer, manufacturers and service provider. The recent issues in a manufacturing industry which occurs regularly and harms the performance of the production line. The issues may be regarding cycle time, Work In Process (WIP), Raw Material Inventory (RMI), improper layout design, utilisation of recourse, on time delivery and flow of materials [4]. By using queuing theory it is possible to enhance the performance of the production line.[7] The aim of all investigations in queuing theory is to get the main performance measures of the system which are the probabilistic properties (distribution function, density function, mean, variance) of the following random variables: number of products/customers in the system, number of waiting products/customers, utilization of the machines/server, response time of a product/customer, waiting time of a product/customer, idle time of the machine/server, busy time of a machine/server. Of course, the answer heavily depends on the assumptions concerning the distribution of interarrival times, service times, number of machine/servers, capacity and service discipline [6].

International Journal of Innovative Research in Science, Engineering and Technology

(An ISO 3297: 2007 Certified Organization)

Vol. 4, Issue 6, June 2015

II. LITERATURE REVIEW

Michael Manitz: described an approximation procedure for determining the throughput of such an assembly line. Exact solutions are not available in this case. For performance evaluation, a decomposition approach is used. The two-station subsystems are analyzed by G/G/1/N stopped-arrival queuing models. In this heuristic approach, the virtual arrival and service rates, and the squared coefficients of variation of these subsystems are determined. A system of decomposition equations which are solved iteratively is presented. Any solution to this system of equations indicates estimated values for the subsystems' unknown parameters.

Na Li, Shiqing Yao, George Liu, Caihua Zhuang: studied the optimization problem in setting the suitable total Work in- Process (WIP) level and the distribution in the three loops from the view of the trade-off between the throughput and the WIP level for the system is addressed. In the proposed model, the system is firstly modelled as a three-loop closed queue network and they propose an approximate method to evaluate the performance. Secondly, a Genetic Algorithm is designed to obtain near optimal results based on the performance evaluation.

Viswanadham and Narahari: offer a unique effort in presenting a unified and systematic treatment of various modeling methodologies and analysis techniques for performance evaluation of automated manufacturing systems. They begin with an overview of automated manufacturing systems, and then move on to provide a comprehensive discussion of three principal analytical modelling paradigms: Markov chains, queues and queuing networks and Petri nets. They also deal with the transient analysis of manufacturing systems performance and the important topic of performability of automated manufacturing systems.

Buzacott and Shanthikumar : who provide a comprehensive treatment of stochastic models of manufacturing systems, and develop stochastic models that evaluate the performance, address issues in the design, control and operation of these systems, and provide an understanding of how different components of a manufacturing system can be coordinated. The authors present new treatments of such classical issues as workload allocation and new models of assembly systems with strict job sequence requirements. In addition, they have developed a new framework to describe the interaction between information and material flow in manufacturing.

Askin and Standridge: provide an introduction to the analysis of manufacturing systems using analytical and experimental models. They bring together useful models and modelling approaches that address a wide variety of manufacturing system design and operation issues.

Papadopoulos, Heavey and Browne: describe the modelling of manufacturing systems using queuing network models and two other closely related modelling techniques, simulation modelling and generative models for the buffer allocation problem. The main purpose of this work is to provide an overview of past research in this area.

III. CASE STUDY UNDER OBSERVATION

A case study which is under observation, last four months data is taken for preliminary analysis. In a company the production of hub is carried out according to monthly demand from customers. Once the customers place order, the production planning and control department schedule for monthly production. They divide monthly production requirement into weekly production requirement and weekly into daily production requirement.

Company is facing problem for delivering the hub after increase in demand from their customer. After studying the past data of component such as, manufacturing process, resources required, work in process inventory and raw material inventory, the organisation facing problems regarding dispatch and inventory control for the component. The problems are listed below,

- Problems associated with dispatch.
- Problems associated with Work-in-process inventory.

International Journal of Innovative Research in Science, Engineering and Technology

(An ISO 3297: 2007 Certified Organization)

Vol. 4, Issue 6, June 2015

After preliminary analysis we have recorded performance measuring parameters from January-15 to April-15 before implementation of waiting line model.

Performance Parameters	Avg. % of OTD	Avg. WIP	Avg. Revenue
Hub	63%	1450	Rs.27,738/-

Fig no. 1 Performance measuring parameters

(Avg OTD- Average On time delivery, Avg WIP- Average Work In Process)

The company is manufacturing only 2500 units of hub per month but requirement is 4000 units per month which means the on time delivery of the hub is only 63%, due to this the numbers of WIP units are increasing and the revenue is decreasing.

Layout of Hub Production Line

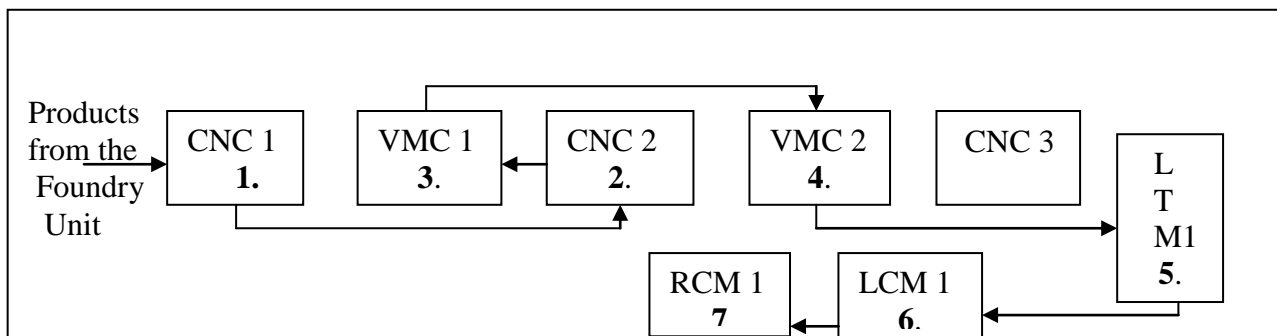

Fig no.2 Layout of Hub Production Line

When casting of hub product is completed from foundry unit the products come to the raw material store point, where the inspections of casting products are carried out. If the products comes with some defects like blow holes, cold shuts, extra material etc. then products are send it to foundry department with proper reason. After these inspections of products, they are sent it to machine shop, with Ok tag. The hub product is machined on four different machining centres (CNC and VMC), one leakage testing centre (LTM), one laser coding centre (LCM) and rotary cleaning machine (RCM). The hub production line consists of CNC1, CNC2, VMC1, VMC2, LTM1, LCM1, and RCM1.

Followings are some issues which observed during preliminary analysis:

1. More cycle time of manufacturing process.
2. Less control over work in process inventory and raw material inventory.
3. Improper layout of the production.
4. Lack of utilization of the resources in the manufacturing production line.
5. More rejection of the manufacturing products.
6. Percentage of on time delivery of products is less.
7. The flow of material between the work stations is more.

IV. METHODOLOGY

The developed methodology for enhancing the production line:-

1. Analysis of current production line by time study to identify the constraint resource:-
By using industrial stop watch and high-definition video recorder the time study has been taken. During this loading time, unloading time, idle time, inspection time is carried out on each machine and each operation.

International Journal of Innovative Research in Science, Engineering and Technology

(An ISO 3297: 2007 Certified Organization)

Vol. 4, Issue 6, June 2015

2. Analysis of current working status with the help of past data, observation, inspection, and check sheet:-
By observing last four months data and inspection done on the floor we observed that there are some issues are presents in current production line which is hampering the performance of production line. Like percentage of on time delivery is less, more numbers of WIP, fluctuating cycle time, flow of material between the work stations is more.
3. Analysis the non value added activities in the plant with the help of DMAIC approach:-
By inspection and past data, there are many non value added activities are observed which can be minimised by using DMAIC approach which is under process. Followings are some non value added activities are observed-Too much sampling and testing, manufacturing downtime, long setup time, lack of planning, holding too much inventory, no schedule for machine maintenance, storage problem, waiting, manual movement etc.
4. Analysis of the amount of work in process (WIP) inventory accumulated in front of each resource.
5. Calculate service rate, work in process (WIP) inventory cost and system waiting cost.
6. Applying waiting line model to each resource of production line to achieving performance improvement of production line.
7. Analyse throughput of whole system at different service levels and suggest performance improvement measures.

FLOWCHART OF METHODOLOGY:

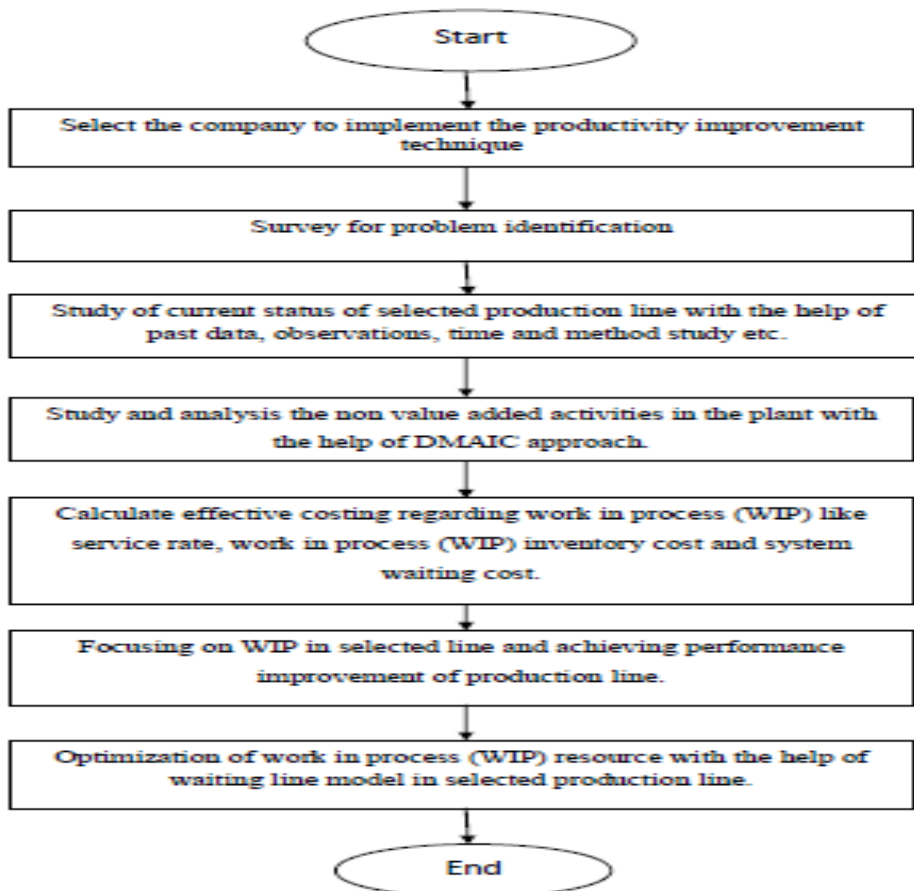

Fig no. 03 Flowchart of Methodology.

International Journal of Innovative Research in Science, Engineering and Technology

(An ISO 3297: 2007 Certified Organization)

Vol. 4, Issue 6, June 2015

V. CONCLUSION

Managing production cost is major challenge in today's manufacturing scenario. Companies are focusing on their production line with the tools such as TPM, TQM, lean tools etc. This papers discusses the application of waiting line model to the production line for performance improvement. Authors are presently focusing on production line of a small scale industry for performance improvement. The preliminary analysis indicates non value added activities due to this company is not able fulfil the customers demand. This provides ample scope in performance improvement.

REFERENCES

- [1] Askin, and Standridge, "Selection machines and buffers in unreliable assembly/disassembly manufacturing networks", Int. J. Production Economics 154, pp.113-126, 2014
- [2] Riyadh Mohammed Ali Hamza., "Selection of Balancing Method for Manual Assembly Line of Two Stages Gearbox", Global Perspectives on Engineering Management, Vol. 2 Iss. 2, PP. 70-81, 2013
- [3] Papadopoulos, Heavey and Browne., "An Efficient Assembly line Balancing in Automobile Manufacturing", IEEE , vol.11, 2011
- [4] Na Li, Shiqing Yao, George Liu, Caihua Zhuang. "Optimization of a multi-Constant Work-in-Process semiconductor assembly and test factory based on performance evaluation", Computers & Industrial Engineering 59, pp. 314–322, 2010
- [5] Michael Manitz., "Queueing-model based analysis of assembly lines with finite buffers and general service times", Computers & Operations Research 35, pp. 2520 – 2536, 2008
- [6] Chung-Jen Kuo., "Standard WIP Determination and WIP Balance Control with Time Constraints in Semiconductor Wafer Fabrication", Journal of Quality Vol. 15, No. 6 ,2008
- [7] Viswanadham and Narahari., "Evaluating focused factory benefits with queuing theory", European Journal of Operational Research 128 , pp. 597-610, 2011
- [8] H.T. Papadopoulos, C. Heavey., "Queueing theory in manufacturing systems analysis and design: A classification of models for production and transfer lines", European Journal of Operational Research 92, pp. 1-27, 1996
- [9] kua, and van der Wal., "Monotonicity of the throughput in single server production and assembly networks with respect to the buffer sizes", in: H. Perros T. Altiok (eds)., Queueing Networks with Blocking, North-Holland, Amsterdam, pp. 345-356, 2011
- [10] Yao.D., "Majorization and arrangement orderings in open queueing networks", Annals of Operations Research 9, pp.53 i-543, 2001
- [11] Papadopoulos, H.T., Heavey, and Browne., "Queueing Theory in Manufacturing Systems Analysis and Design", Chapman and Hall, London, 2012
- [12] Nakata, and Kostelski, "Matrixgeometric and recursive algorithm solution of a two-stage unreliable flow line", HE Transactions 19/4, pp. 429-438, 1999
- [13] Azmat Nafees., "Queueing theory and its application: Analysis of the sales checkout operation in ICA supermarket", University of Dalarna, Department of Economics and Society, vol 06, 2007

BIOGRAPHY



Santosh Kulkarni is PG student studying M.E Mech. (Prod) in K I T's College of Engineering, Kolhapur. The topic of his dissertation is Performance Improvement of Production Line.



Mr. Girish R. Naik, Associate Professor Dept of Prod Engg. in K I T's College of Engineering, Kolhapur. M.E.(Mech-Prod.), B.E.(Indl.Prod.), D.C.P, D.B.M, PhD(Pursuing), Academic experience 26 Years, Publications – 45